



Installation Instructions



IMPORTANT: For proper acoustic isolation, *QuietZone* Acoustic Floor Mat must be laid on a clean, dry and level surface covering the entire floor area with the mat turned up at each wall and should be installed after the drywall has been applied. A gypsum concrete or two-layer plywood raft is installed to “float” on top of the floor mat and provide a rigid surface for finished flooring.

Excellent Acoustical Performance

QuietZone Acoustic Floor Mat, composed of a lightweight, closed cell, extruded polyethylene foam, is acoustically engineered to isolate sound vibrations and impact noises. Wall performance will also increase, as flanking noise will be reduced.

Commercial applications, such as hotel rooms, conference rooms and condominiums as well as residential applications like home theaters or laundry rooms are ideal areas for noise control treatment.

Typical Physical Properties

Property	Test Method	Value
Compressive Strength, Vertical Direction	ASTM D3575 93 Suffix D @ 25%/50%	518/1728 (psf)
Compression Set (50% deflection requires a loading of 1800 psf)	ASTM D3575 93 Suffix B	26% (74% Recovery)
Nominal Density	ASTM C303	2.2 (pcf)
Water Absorption	ASTM D3575 93 Suffix L	<0.1 (psf)
Thermal Resistance R-Value	ASTM C518 85	0.96 (Hr•Ft. ² •°F/BTU)
Surface Burning Characteristics	ASTM E84 ¹	
Flame Spread		0
Smoke Developed		70

¹ASTM E84 is a standard used to measure and describe the properties of materials, products or assemblies in response to heat and flame under controlled laboratory conditions using proper construction techniques and assembly. Improper installation can adversely affect fire performance.

Technical Data

Property	Test Method
Material	Polyethylene foam with an anti-static agent
Package Form	Roll
Length	35 ft.
Width	4 ft.
Area	140 Sq. Ft.
Thickness	3/8 in. (9.5mm)
Roll Diameter	14 in.
Roll Weight	10.25 lbs.

Specification

Sound rated floor material shall be 3/8" (9.5mm) thick closed cell polyethylene foam with an anti-static agent. The sound rated material shall be *QuietZone* Acoustic Floor mat as supplied by Owens Corning.

Durable Material Composition

QuietZone Acoustic Floor Mat has exceptional compressive strength, while also being resilient enough to absorb impact vibrations. It will retain its acoustic properties over time while also being resistant to moisture, mold and fungus.

Fast, High Quality Installation

QuietZone Acoustic Floor Mat is lightweight, easy to cut and install. Installed beneath 1 1/2" or 1" gypsum concrete or a double layer of 3/8" exterior-grade plywood and finished flooring, *QuietZone* Acoustic Floor Mat isolates and minimizes structure-borne noise from transferring to adjacent areas or rooms. Refer to product packaging for complete installation instructions.



Installation Instructions

Installation with Plywood Raft

Note: for use with

- hardwood
- vinyl
- wood laminate
- carpet and padding

I. Install Floor Mat

- Roll out *QuietZone* Acoustic Floor Mat directly on top of the subfloor so that the entire floor surface area is covered and 3-4" of floor mat is turned up along wall.
- Butt adjoining edges of floor mat against each other and tape all seams with standard (2" wide) building tape. Also, tape the turned up edges to the wall to help with installation of the wood raft.
- Ensure the *QuietZone* Acoustic Floor Mat is free of any tears or punctures.

2. Install Plywood Raft on Top of Floor Mat

- Combine two layers of $\frac{3}{8}$ " (or thicker), exterior, AC-grade plywood together. (Note: two layers of $\frac{1}{2}$ " plywood should be used with hardwood finished flooring.) Select plywood that is uniform, flat, dry and free of defect to ensure that the finished floor is level. Allow the plywood to become acclimated to the environment so that the wood is dry and the moisture content has stabilized. This can be done by standing the panels on edge for several days in the rooms where they will be

installed. It is recommended that all of the plywood raft pieces needed are pre-cut prior to assembly.

- Place one layer of plywood directly on top of the floor mat so the entire surface area is covered. Space the plywood panels so that there is a $\frac{1}{8}$ " gap between adjacent pieces of plywood and from the walls.
- Apply an even coat of standard wood glue to the top surface of bottom layer of plywood, and then place a second layer of plywood onto glued surface. The second layer of plywood should be oriented perpendicular to the bottom layer with the joints staggered. The finished surface of the plywood forms the top surface of the raft. Space the plywood panels so that there is a $\frac{1}{8}$ " gap between adjacent pieces of plywood and from wall.
- Fasten the two layers of plywood together using $\frac{3}{4}$ " long wood screws spaced 12" apart across entire surface area, including the joints and perimeter. Use 1" long screws when $\frac{1}{2}$ " plywood is being installed.

NOTE: Since wood is a natural material, it is susceptible to dimensional change. Providing a gap around all edges of the plywood panels should accommodate any dimensional change. However, in the event that the plywood raft does not lay evenly over the *QuietZone* Acoustic Floor Mat, one may selectively screw

down the plywood raft (up to 16" oc) without significantly compromising the acoustic performance of the system. Care should be taken to use wood screws that completely penetrate the subfloor without entering into the floor joists.

3. Install Finished Flooring

- Install the finished flooring as recommended by the manufacturer.
- Ensure that the finished flooring is installed close enough to the wall so that the finishing trim will conceal the *QuietZone* Acoustic Floor Mat.

4. Clean-up

- Remove tape from wall.
- Trim away excess *QuietZone* Acoustic Floor Mat so that the mat is flush with the finished floor.
- Add baseboard or finishing trim as required.

Installation with Gypsum Concrete Raft

Note: for use with

- hardwood
- vinyl
- ceramic tile
- wood laminate
- carpet and padding

I. Install Floor Mat

- Roll out *QuietZone* Acoustic Floor Mat directly on top of the subfloor so that the entire floor surface area is covered and floor mat just touches the wall.

Installation Instructions

Figure 1

Wood Frame Construction

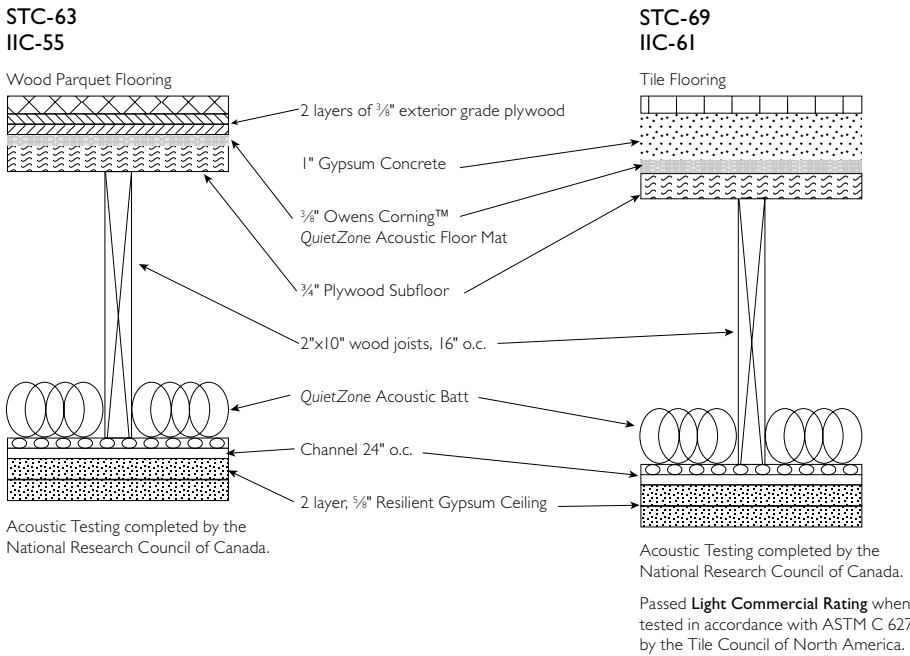

- Butt adjoining edges of floor mat against each other and tape all seams with standard (2" wide) building tape.

- Cut a strip of *QuietZone* Acoustic Floor Mat 3-4" wide and place strip along wall and tape edge to the floor mat on the subfloor.

NOTE: Floor mat strip should form a sealed, right angle with the floor mat on the subfloor.

- Tape the top of the perimeter strip to the wall so that the gypsum concrete can fill the entire floor surface area.
- Ensure the *QuietZone* Acoustic Floor Mat is free of any tears or punctures.

Figure 2

Concrete Slab Construction

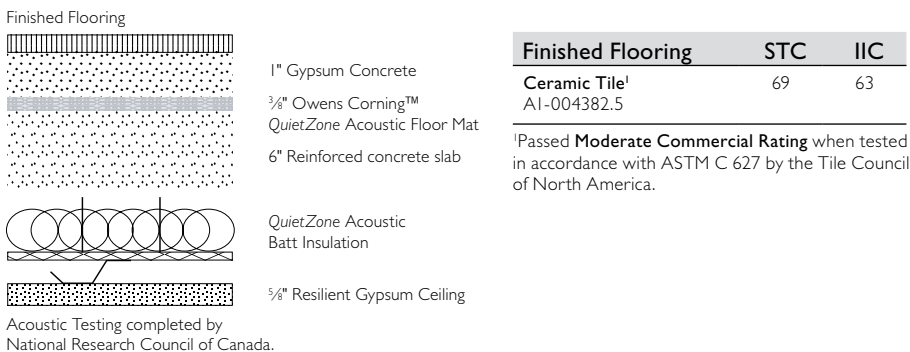

2. Install Gypsum Concrete Raft on Top of Floor Mat

- Pour the lightweight gypsum concrete material per

Figure 3

Installation with Plywood Raft

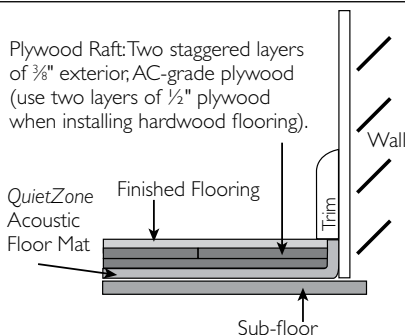
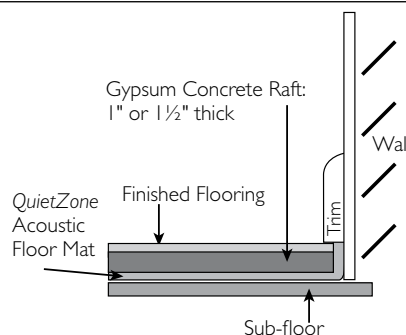

Figure 4

Installation with Gypsum Concrete Raft



CAUTION: COMBUSTIBLE. This product should not be exposed to open flames or other possible ignition sources. It may contain flammable vapors and should be stored in well ventilated areas. Further processing of the product may result in the localized release of flammable vapors. This product should be installed in such a way that it is separated from the building interior by a thermal barrier. Typical thermal barriers are a minimum of 5/8" plywood or 1" thick concrete. Please refer to the Material Safety Data Sheet for more information.



Installation Instructions

manufacturer's instructions on top of the *QuietZone* Acoustic Floor Mat so there is a layer of gypsum concrete at least 1½" thick covering the entire floor surface area.

3. 1" Alternative to Gypsum Concrete Using USG LEVELROCK® Brand Floor Underlayment 2500 or 3500

- Apply USG LEVELROCK® Brand Floor Primer or equivalent over *QuietZone* Acoustic Floor Mat following manufacturer's instructions for mixing and application.
- Pour USG LEVELROCK® Brand Floor Underlayment 2500 or 3500 over floor primer to a minimum thickness of 1". Follow manufacturer's instructions for mixing and application.
- Depending on the finish floor application, apply LEVELROCK™ Brand Surface Enhancer SE-100 over the USG LEVELROCK® gypsum concrete topping. Follow manufacturer's instructions to determine when and how to apply.
- For a tile finish floor add: Noble Company, NobleBond 21 Adhesive following manufacturer's instructions Noble Company, NobleBond CIS Crack Suppression Membrane following manufacturer's instructions

4. Clean-up

- Remove tape from wall.
- Trim away excess *QuietZone* acoustic floor mat so that the mat is flush with the finished floor.
- Add baseboard or finishing trim as required.

Design Considerations

QuietZone Acoustic Floor Mat is to be placed between the subfloor and plywood or gypsum concrete overlayment to create an isolation layer for sound vibrations and impact noises such as foot traffic. The plywood or gypsum concrete overlayment, once installed, "floats" on top of the floor mat providing a rigid surface for the finished flooring.

Fire Safety & Applicable Standards

QuietZone Acoustic Floor Mat has been tested in accordance with ASTM E84 with resulting flame spread/smoke developed indices of 0/70. Thermal barrier and structural requirements are met by using 1" of gypsum concrete or 2 layers of ¾" exterior grade plywood.

Always check with your local building code official regarding local requirements affecting installation of all building components.

For more information, call 1-800-GET-PINK® or visit our Web site at: www.quietzone.com



OWENS CORNING INSULATING SYSTEMS, LLC
ONE OWENS CORNING PARKWAY
TOLEDO, OHIO 43659
1-800-GET-PINK®
www.owenscorning.com

Pub. No. 102322-E. Printed in U.S.A. September 2014. THE PINK PANTHER™ & ©1964-2014 Metro-Goldwyn-Mayer Studios Inc. All Rights Reserved. The color PINK is a registered trademark of Owens Corning. ©2014 Owens Corning. All Rights Reserved.

