

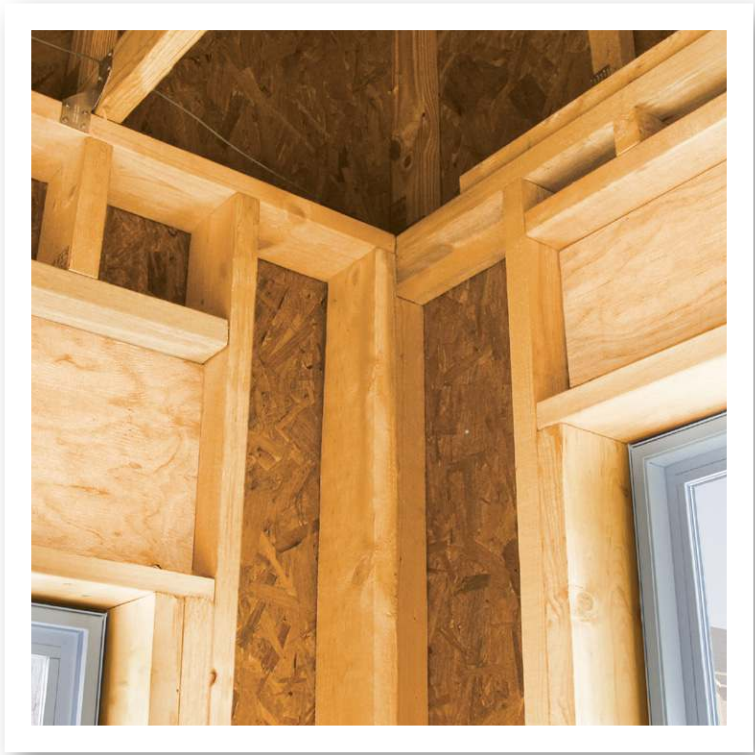

Advanced Framing

CONSTRUCTION GUIDE



WOOD

The Natural Choice



Engineered wood products are a good choice for the environment. They are manufactured for years of trouble-free, dependable use. They help reduce waste by decreasing disposal costs and product damage. Wood is a renewable resource that is easily manufactured into a variety of viable products.

A few facts about wood.

- **We're growing more wood every day.** Forests fully cover one-third of the United States' and one-half of Canada's land mass. American landowners plant more than two billion trees every year. In addition, millions of trees seed naturally. The forest products industry, which comprises about 15 percent of forestland ownership, is responsible for 41 percent of replanted forest acreage.



That works out to more than one billion trees a year, or about three million trees planted every day. This high rate of replanting accounts for the fact that each year, 27 percent more timber is grown than is harvested. Canada's replanting record shows a fourfold increase in the number of trees planted between 1975 and 1990.



- **Life Cycle Assessment shows wood is the greenest building product.**

A 2004 Consortium for Research on Renewable Industrial Materials (CORRIM) study gave scientific validation to the strength of wood as a green building product. In examining building products' life cycles – from extraction of the raw material to demolition of the building at the end of its long lifespan – CORRIM found that wood was better for the environment than steel or concrete in terms of embodied energy, global warming potential, air emissions, water emissions and solid waste production. For the complete details of the report, visit www.CORRIM.org.

- **Manufacturing wood is energy efficient.**

Wood products made up 47 percent of all industrial raw materials manufactured in the United States, yet consumed only 4 percent of the energy needed to manufacture all industrial raw materials, according to a 1987 study.

Material	Percent of Production	Percent of Energy Use
Wood	47	4
Steel	23	48
Aluminum	2	8



- **Good news for a healthy planet.** For every ton of wood grown, a young forest produces 1.07 tons of oxygen and absorbs 1.47 tons of carbon dioxide.

Wood: It's the natural choice for the environment, for design and for strong, lasting construction.



NOTICE:

The recommendations in this guide apply only to products that bear the APA trademark.

Only products bearing the APA trademark are subject to the Association's quality auditing program.

Advanced Framing

Advanced framing with 2x6 wood studs spaced 24 inches on center, combined with wood structural panel sheathing, is one of the most cost-effective solutions for builders trying to balance increasingly stringent energy codes with structural building code requirements.

Advanced framing is a system of framing techniques based on optimizing building materials to produce wood-framed buildings with lower material and labor costs than conventionally framed structures. Builders who utilize advanced framing techniques optimize framing material usage, reduce wood waste and, with effective insulation detailing, boost the building's efficiency to meet today's energy code requirements. When properly designed and constructed, advanced framed walls that are fully sheathed with wood structural panels, such as plywood or oriented strand board (OSB), provide the structural strength necessary to safely withstand the forces of nature.

This construction guide from APA – *The Engineered Wood Association* details advanced framing techniques that will produce energy efficient, structurally sound homes with lower material and labor costs than conventionally framed houses. (Note that some included details may require engineering by a design professional.)

CONTENTS

COMPONENTS OF ADVANCED FRAMING	4
ADVANCED FRAMING DEFINED	5
ADVANTAGES OF ADVANCED FRAMING	5
<i>Energy Efficiency</i>	5
<i>Cost Effectiveness</i>	6
<i>Structural Integrity</i>	7
<i>Sustainability</i>	7
INCORPORATING ADVANCED FRAMING TECHNIQUES	8
FLOOR FRAMING	8
WALL FRAMING	9
<i>Stud Spacing</i>	10
<i>Corners</i>	10
<i>Interior Wall Intersections</i>	11
<i>Prescriptive and Alternate Connection Details</i>	11
<i>Headers</i>	13
<i>Wood Structural Panel Box Headers</i>	14
<i>Openings</i>	15
<i>Blocking</i>	16
<i>Metal Hardware</i>	16
SINGLE TOP PLATES	17
<i>Ceiling and Roof Framing</i>	17
<i>Single Top Plates and Framing Member Layout</i>	18
WALL SHEATHING	18
<i>Wind Resistance and Wall Assemblies</i>	18
<i>Wall Bracing</i>	20
MORE INFORMATION	21
<i>Engineered Wood Construction Systems</i>	21
<i>Building Codes Referenced in this Guide</i>	22
<i>Additional References</i>	22
<i>Acknowledgements</i>	22
<i>About APA</i>	23

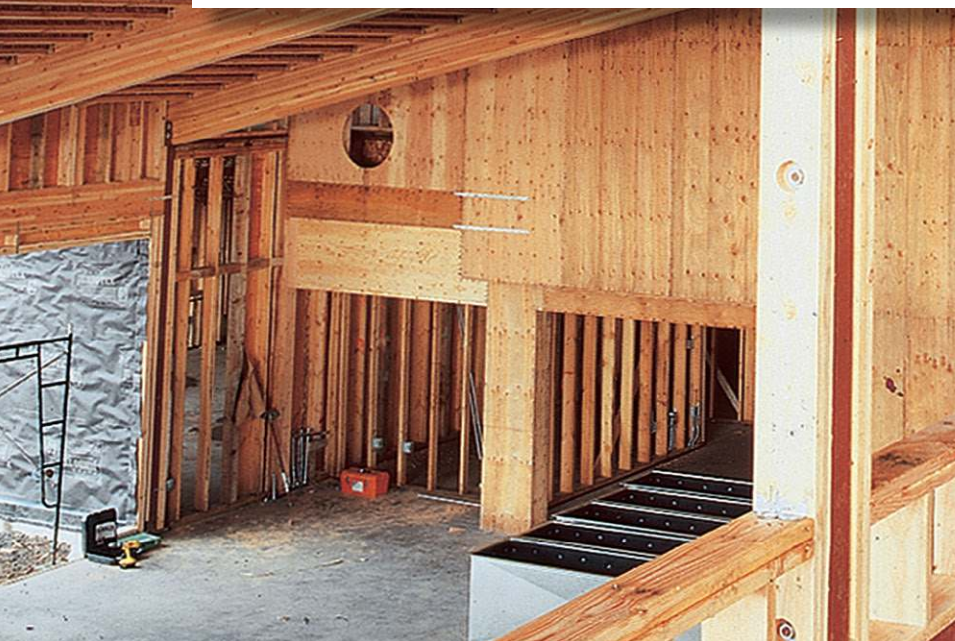

COMPONENTS OF ADVANCED FRAMING

Houses constructed with advanced framing techniques may include some or all of the following details:

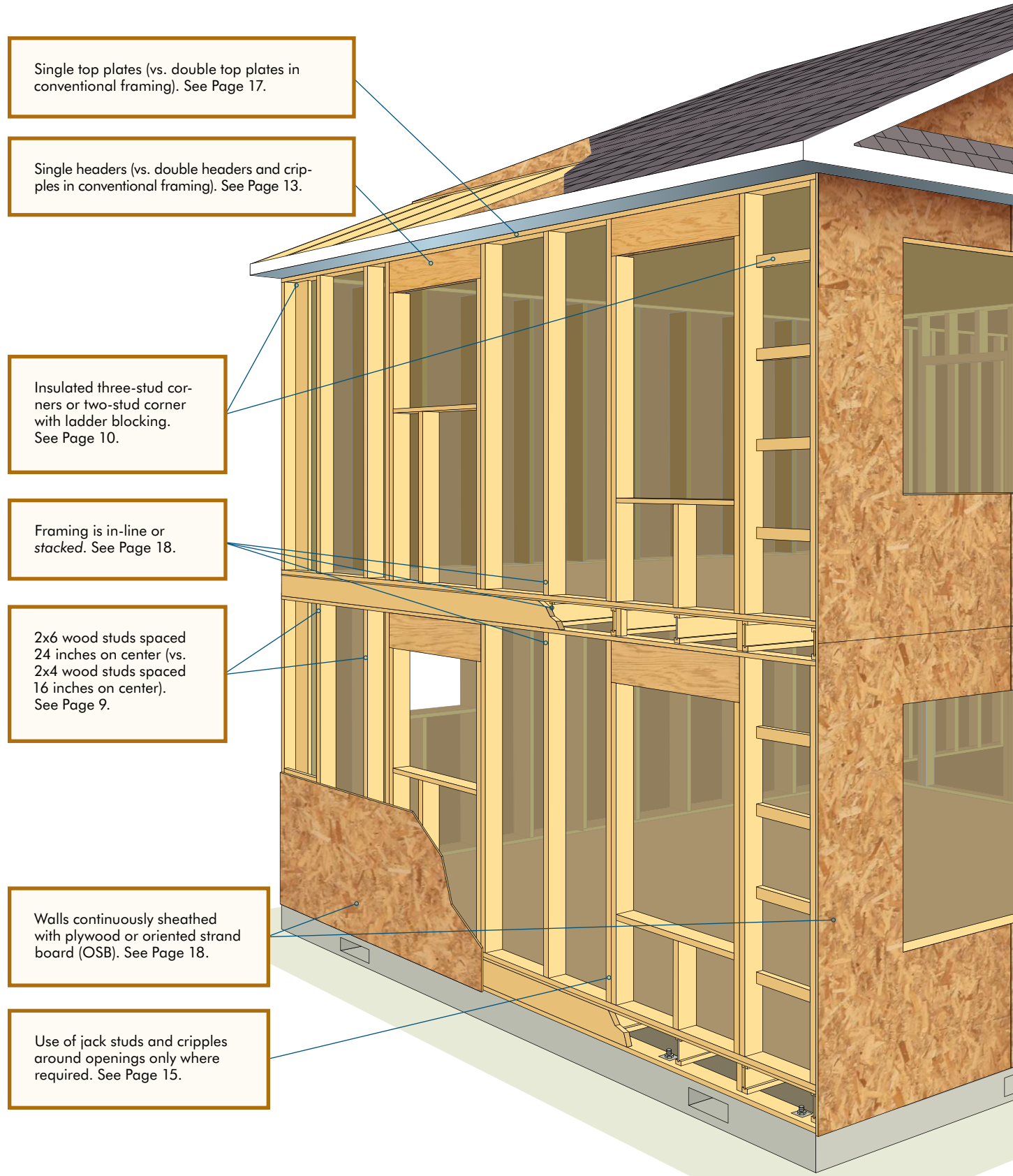

ADVANCED FRAMING DEFINED

Advanced framing is a system of construction framing techniques designed to optimize material usage and increase energy efficiency. Structures built with advanced framing techniques are more resource efficient and offer more space for cavity insulation than similar structures built with conventional framing.

Conventional framing, the industry standard for framing residential construction, typically consists of 2x4 or 2x6 wood framing spaced 16 inches on center, double top plates, three-stud corners, multiple jack studs, double or triple headers, unnecessary cripple studs and other redundant members.

Advanced framing reduces the unnecessary structural redundancies inherent in conventional framing by placing framing members only where they're needed. The most commonly adopted advanced framing technique is 2x6 wood framing spaced 24 inches on center. Other commonly used techniques include single top plates, two-stud corners, single headers, minimal use of jack studs and cripples, and the elimination of redundant studs and unnecessary blocking and bridging. Although some advanced framing techniques can be adopted independently, the greatest savings – in both cost of construction and energy – will be realized when the system is applied holistically.

Advanced framing – also known as *optimum value engineering (OVE)* – was developed by the NAHB Research Center, an independent subsidiary of the National Association of Home Builders (NAHB), in the 1970s for the purpose of optimizing material usage while maintaining structural integrity. Today, growing interest in energy conservation is leading more and more builders to adopt advanced framing techniques.

APA recommends that you consult your local building official early in the design phase to verify and obtain acceptance of 24-inch framing techniques in your jurisdiction.

ADVANTAGES OF ADVANCED FRAMING

Advanced framing produces energy efficient, structurally sound homes with lower material and labor costs than conventionally framed houses. The key advantages of advanced framing include:

Energy Efficiency

Advanced framing is a proven method for cost-effectively meeting energy code requirements. By maximizing space for cavity insulation and minimizing the potential for insulation voids, advanced framing delivers significant energy performance and cost savings for the builder.

Walls built with 2x6 wood framing spaced 24 inches on center have deeper, wider insulation cavities than conventional 2x4 framing spaced 16 inches on center. Increasing the amount of insulation inside the wall improves the whole wall R-value (resistance to heat flow). Figure 1 shows

FIGURE 1

WALL SYSTEMS THAT MEET R20 WALL REQUIREMENTS* (Whole Wall R-value Comparisons)

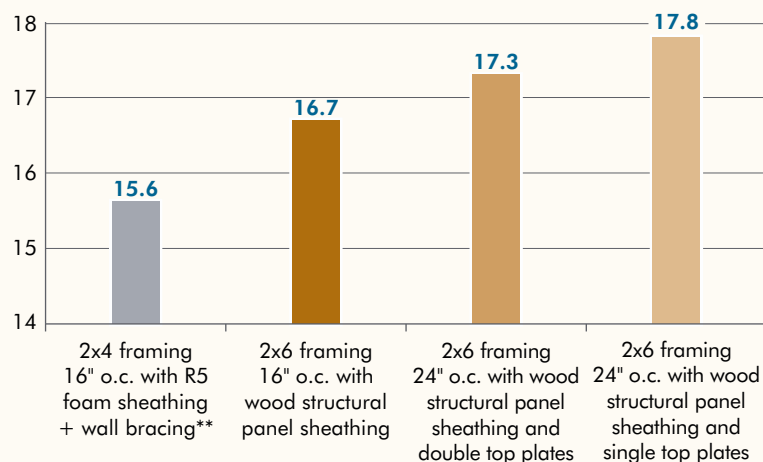

*Evaluation based on uninsulated headers and R21 cavity insulation in 2x6 walls.

**Represents a typical foam sheathed wall meeting R20 requirements in accordance with the 2012 IECC, Table R402.1.1. Assumes 40% structural wall bracing covered with R2 foam sheathing.

advanced framed R20 code-compliant wall systems provide a greater whole wall R-value than conventionally framed 2x6 walls or code-minimum 2x4 walls sheathed with foam.

In addition to maximizing space for cavity insulation, advanced framing simplifies the installation of insulation and air sealing. Conventional framing can leave voids and small cavities in the framing at wall intersections and corners that can be difficult to insulate and seal effectively. By installing fewer framing members, it is easier for the builder to apply complete insulation coverage and achieve a tighter building envelope.

As energy codes have become increasingly stringent, advanced framing has grown more popular in climate zones where high prescriptive wall R-values are mandated or desired. While framing with 2x6 studs spaced 16 inches on center is already common in many northern states with more restrictive energy demands, increasing stud spacing to 24 inches on center, insulating effectively, and fully sheathing with wood structural panels, such as plywood or oriented strand board (OSB), allows builders to cost-effectively balance energy and structural code requirements.

The ENERGY STAR® program was developed by the U.S. Environmental Protection Agency to promote the use of energy efficient products and practices. Advanced framing can help builders meet the requirements necessary to earn the ENERGY STAR label for new homes. Advanced framing techniques qualify as Reduced Thermal Bridging under section 4.4.5 of the Thermal Enclosure System Rater Checklist (ver. 3, rev. 5). These techniques must be incorporated to earn the ENERGY STAR label when using section 4.4.5 of the Checklist.



The framing width and spacing requirements for the Thermal Enclosure System Rater Checklist vary by climate zone:

- 16 inches on center (minimum) spacing if using 2x4 framing
- 24 inches on center (minimum) spacing if using 2x6 framing in colder climates (zones 5-8)
- 16 inches on center (minimum) spacing if using 2x6 framing in warmer climates (zones 1-4)

In addition, the following advanced framing techniques must also be incorporated to meet the thermal bridging requirements of the checklist:

- Insulated corners (R6 minimum) (Page 10)
- Insulated headers (R3 minimum for 2x4 construction, R5 minimum for 2x6 construction) (Page 13)
- Window and door framing, per opening — one pair of king studs, one pair of jack studs, and cripples only to maintain on-center spacing. Additional framing is allowed if required for structural support. (Page 15)
- All interior-exterior wall intersections insulated to the same R-value as the rest of the exterior wall (Page 11)



Insulated corners and headers are required for use of section 4.4.5 of the ENERGY STAR Thermal Enclosure System Rater Checklist. Two-stud corners (Figure 4) and single-ply headers (Figure 7) can be easily insulated to meet these requirements.

By implementing these modest and cost-effective framing changes, ENERGY STAR builders can maintain their use of wood structural panel wall sheathing. Plywood and OSB wall sheathing allows for greater architectural flexibility in the number and location of door and window openings, often without necessitating re-engineering due to additional wall bracing area that is typically required with other types of wall sheathing.

Follow ENERGY STAR program guidelines for climate-specific installation requirements and recommendations. Visit www.energystar.gov for more information.

Structural Integrity

The advanced framing method combined with continuous wood structural panel sheathing delivers builders with an optimal solution: a cost-effective framing system that will produce more energy efficient homes without compromising the strength or durability of the structure.

Where builders align the vertical framing members under the roof trusses or rafters, a direct load path is created in which compression and tension loads are directly transferred through the vertical framing members (Figure 13). The result is a stronger structure with fewer framing members subject to stresses.

When properly constructed, advanced framed walls that are fully sheathed with wood structural panels provide the structure with the strength to safely withstand design loads. Of all the available wall sheathing products, wood structural panels are afforded the most flexibility within the building code for 24-inch on center wall framing, providing solutions to code limitations that restrict most other wall bracing materials and popular siding products.

Wall bracing solutions: Due to their superior structural performance, continuous sheathing with wood structural panels is code-recognized as wall bracing for studs spaced up to 24 inches on center. Most other wall bracing methods, including let-in bracing and some alternative panel products, are limited by the code to 16-inch on center framing. (Refer to building code requirements or manufacturer ICC-ES reports for more information.)

Siding attachment solutions: The most common and cost-effective grades of vinyl siding require fastening into studs every 16 inches. However, the nailbase capabilities of a continuously sheathed wood structural panel wall allow the use of these siding products with 24-inch on center framing because the sheathing also serves as a base for fastener attachment between studs. This saves the builder the potential added cost and hassle of having to change siding products. (Refer to siding manufacturer ICC-ES reports and *APA Technical Topics: Wood Structural Panels Used as Nailable Sheathing*, Form TT-109, for more information.)

Wall sheathing systems that incorporate plywood and OSB offer the best balance of energy efficiency, structural performance and affordability. Wood sheathed walls allow for easy integration of windows into the weather resistive barrier and are simple to insulate with all types of cavity insulation for high R-values. Plywood and OSB sheathing also provides shear strength to resist the forces of nature. For more information, refer to APA's *Introduction to Wall Bracing*, Form F430.

Sustainability

Wood construction systems such as advanced framing techniques fit well with green building strategies. Wood is a renewable resource that is manufactured in efficient processes that require less energy than is required for other building materials, such as steel and concrete.

Wood-frame construction that utilizes advanced framing techniques delivers even greater environmental dividends by optimizing material usage and reducing construction waste. Many of the construction techniques presented in this guide may be eligible for points under the leading green building standards and guidelines, such as the National Green Building Standard™ (ICC 700-2008) and the U.S. Green Building Council LEED® for Homes Rating System.

The ICC 700, established by the National Association of Home Builders (NAHB) and the International Code Council (ICC) in 2007, awards points to builders that incorporate green practices into single- and multifamily home construction and residential remodeling projects. This includes the implementation of building-code-compliant advanced framing techniques in design and construction. ICC 700 Section 601.2 awards 3 points for each qualifying advanced framing technique implemented that exceeds 80 percent usage in the building, and 9 points maximum if the techniques are used for all floor, wall and/or roof framing. For more information, visit www.nahbgreen.org/NGBS.

INCORPORATING ADVANCED FRAMING TECHNIQUES

Because significant changes in framing practices, such as eliminating double top plates in favor of single top plates, may initially require increased effort at the design stage and oversight during construction, many builders elect to incorporate advanced framing in stages rather than all at once. If increased energy-efficiency is a primary reason for converting to advanced framing, the following steps are recommended. Note that not all advanced framing techniques are required; builders may elect to incorporate fewer than all four steps depending on their circumstances.

1. Switch to 2x6 studs to increase cavity insulation depth and meet R20 energy code requirements. (Especially important in colder climate zones.)
2. Where permitted by structural code requirements, change the wall framing module from 16 inches on center to 24 inches on center to reduce framing costs. Retain the use of double top plates to avoid in-line, or *stack*, framing alignment requirements.
3. Incorporate intersecting wall techniques and energy efficient corners, such as three-stud corners and ladder junctions, that allow for greater insulation volume. Implement energy-efficient headers and limited framing around openings.
4. Eliminate double top plates. Because this step requires vertical framing alignment, including 24-inch on center floor and roof framing as well as non-industry standard stud lengths which may be difficult to source, it is often the last technique builders consider. For these reasons, many builders elect to retain double top plates.



Ladder junctions at interior-exterior wall intersections (Figure 5) produce wall cavities that can be easily insulated to help builders earn the ENERGY STAR® label for new homes.

Whatever techniques are selected, it is important that the advanced framing details are clearly specified on the architectural plans when submitted to the building department. Note that if framing crews are unfamiliar with advanced framing, additional onsite supervision and quality control oversight should be planned while framers learn these new techniques.

FLOOR FRAMING

Floor framing is generally subject to home design, foundation requirements and customer expectations, but substantial resource and cost savings can still be realized when the principles of advanced framing are applied. To achieve optimum resource efficiency:

1. Specify engineered wood floor joists, such as I-joists, structural composite lumber (SCL), and/or glulam at 24 inches on center.
2. Maximize member spans between supports.

Specifying engineered wood products, such as I-joists, SCL, and/or glulam, instead of dimension lumber for band joists and floor beams will produce substantially greater spans between foundation elements. Maximizing member spans will increase construction efficiency while reducing construction costs. Additional cost savings will result from reduced cutoff waste generated from a reduced number of framing members.

Spacing engineered wood floor joists 24 inches on center will reduce the number of joists required by about 30 percent as compared to conventional 16-inch floor joist spacing. Note that deeper or larger joists may be required. Some floor serviceability characteristics, such as floor vibration, may also need to be considered. For information on minimizing floor vibration, refer to *APA Technical Note: Minimizing Floor Vibration by Design and Retrofit*, Form E710.

Engineered wood I-joists, SCL and glulam members are commonly available in a variety of depths to provide cost-efficient floor framing. Specifying I-joist floor systems between finished floors will typically allow for the installation of plumbing, electrical and mechanical services within the floor frame cavity, eliminating the need for dropped ceilings.

When installing floor sheathing, keep in mind that many of today’s home buyers expect stiffer, more solid feeling floors. Consider using thicker panels with 24-inch on center floor framing to enhance floor stiffness. The extra cost of thicker sheathing will often be offset by the lower cost of floor framing. Refer to flooring manufacturer for installation recommendations for 24-inch on center floor framing systems.

WALL FRAMING

Of the three primary structural frame components — the floor, wall and roof — the wall frame provides the most opportunities for material savings when advanced framing techniques are used in place of conventional framing methods (Figure 2).

Conventional framing typically consists of 2x4 or 2x6 wood framing spaced 16 inches on center, double top plates, three-stud corners, multiple jack studs, double or triple headers, redundant cripple studs and unnecessary framing members.

Advanced framing typically includes 2x6 wood framing spaced at 24 inches on center and some or all of the following techniques: single top plates, two-stud corner junctions, minimal use of jack studs and cripples, and the elimination of redundant studs and unnecessary blocking and bridging. Correctly sized load-bearing headers are used over openings in load-bearing walls; simple non-load-bearing headers are used in non-load-bearing walls, where applicable.

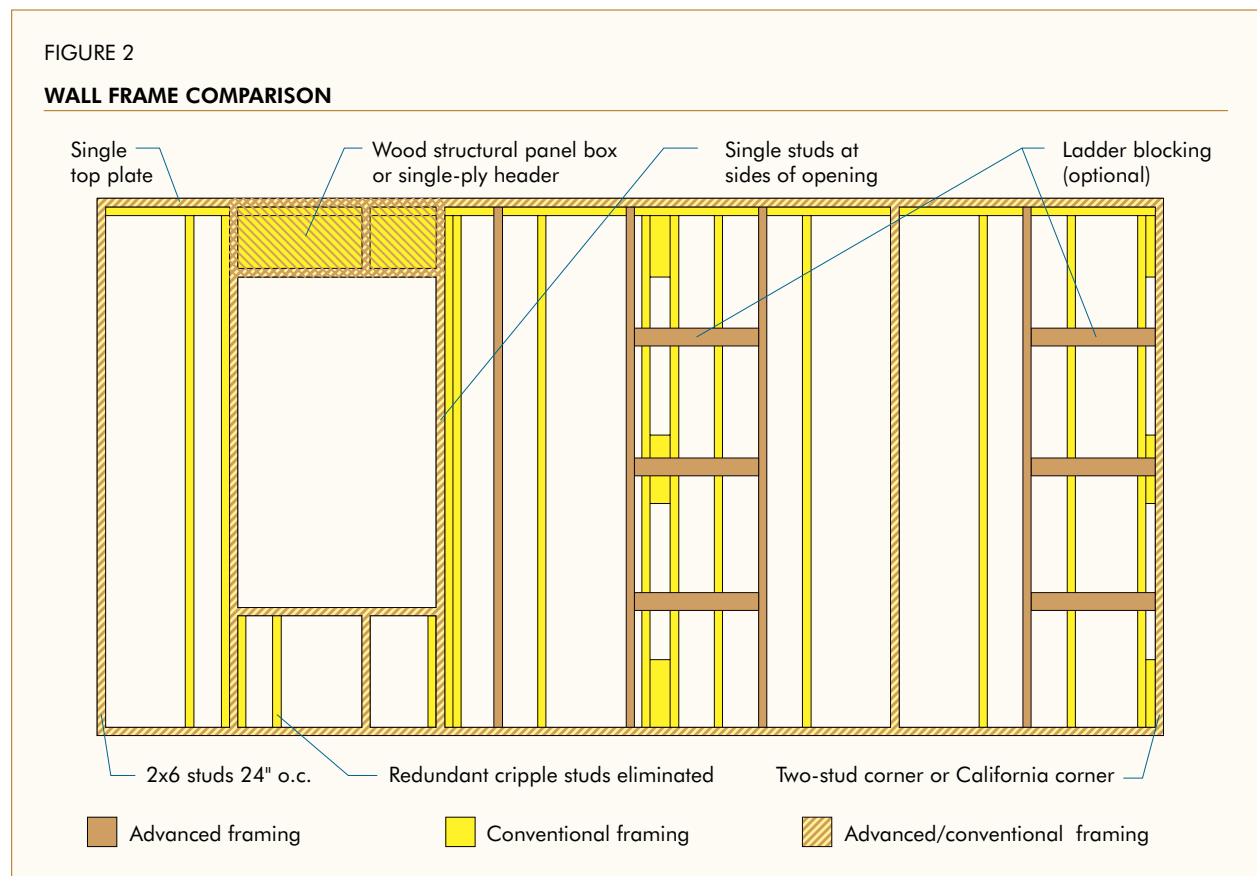

In addition to improving framing efficiency, advanced framing also boosts whole wall R-value (resistance to heat flow) by maximizing space for cavity insulation. When advanced framing techniques are employed — including insulated headers — the reduction in the amount of framing materials can result in up to 12 percent more insulated space within the exterior wall.

Stud Spacing

Framing members are conventionally spaced 16 inches on center. Advanced framing methods increase member spacing, typically to 24 inches on center (Figure 2). This stud spacing fits well with all commonly used sheathing, insulation and finish materials.

Corners

The 2012 IRC (International Residential Code) Figure R602.3(2) *Framing Details - Corner And Partition Posts* provides wall corner and interior wall intersection detail illustrations with alternative configurations and specifies the following:

A third stud and/or partition intersection backing studs shall be permitted to be omitted through the use of wood backup cleats, drywall clips or other approved devices that will serve as adequate backing for the facing materials.

Advanced framing wall corners can include insulated three-stud corners (sometimes referred to as California corners) as shown in Figure 3, or two-stud corner junctions with ladder blocking, drywall clips, or an alternative means of supporting interior or exterior finish materials as shown in Figure 4. These techniques eliminate the isolated cavity found in conventional three-stud corners, making it easier to install insulation and providing more cavity insulation space at exterior insulated wall corners.

FIGURE 3

THREE-STUD CORNERS

INSULATED THREE-STUD CORNER (CALIFORNIA CORNER)

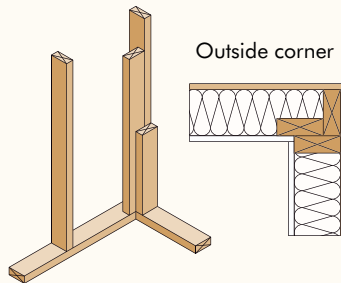

CONVENTIONAL CORNER

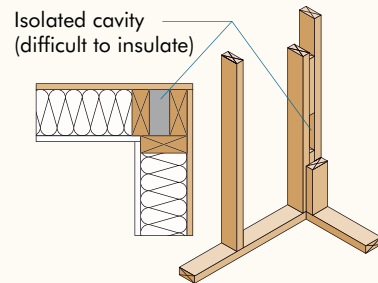

INSULATED THREE-STUD CORNER (INSIDE CORNER)

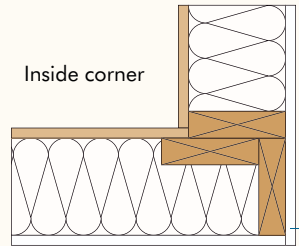

ALTERNATE INSULATED THREE-STUD CORNER (WITH DRYWALL CLIPS)

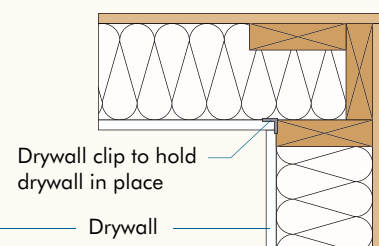
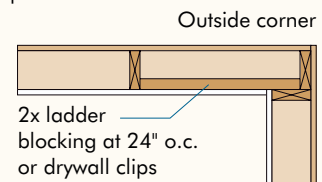
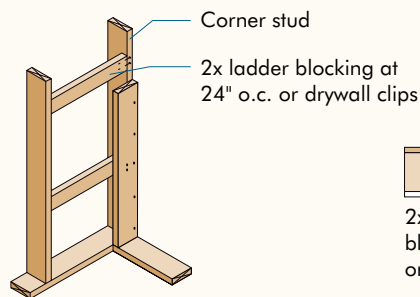
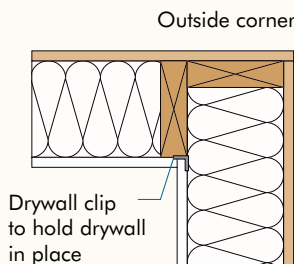

FIGURE 4

TWO-STUD CORNERS



TWO-STUD CORNER (WITH DRYWALL CLIPS)



TWO-STUD INSIDE CORNER (FOR WALL PANELIZATION)

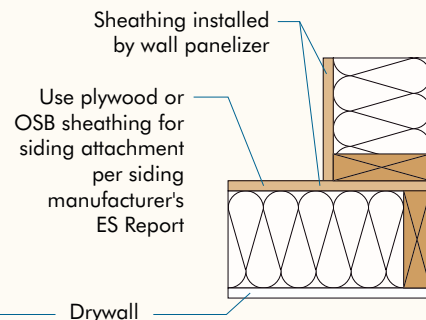

Interior Wall Intersections

Advanced framing ladder junctions are used at wall intersections with 2x blocking at 24-inch on center vertical spacing (Figure 5). This method requires less than 6 feet of blocking material in a typical 8-foot wall. In conventional walls, interior wall intersections include a stud at each side of an intersecting wall, requiring a total of 16 feet of stud lumber plus additional blocking material.

The advanced framing ladder junction method, when used at junctions between interior and exterior walls, provides a cavity that can be easily insulated, while conventional three-stud interior wall intersections may be considerably more difficult to insulate.

Wall intersections that feature a continuous drywall application (Figure 5) minimize air infiltration by reducing the amount of joints in the drywall.

Drywall clips can be used in place of ladder blocking. Drywall is not fastened to the clips; it is held against the clips by the installation of drywall to the adjacent wall. In all cases, it is recommended to install at least one ladder block at the mid-height of the wall to restrain the adjacent stud in a straight plane.

Prescriptive and Alternate Connection Details

In lieu of using metal plates to make single top plate connections, framing cutoffs can be used as shown in Figure 6. Cutoffs can also be sized and placed to provide support for ceiling gypsum wallboard.

FIGURE 5

INTERIOR WALL INTERSECTION OPTIONS

LADDER JUNCTION

Single top plate

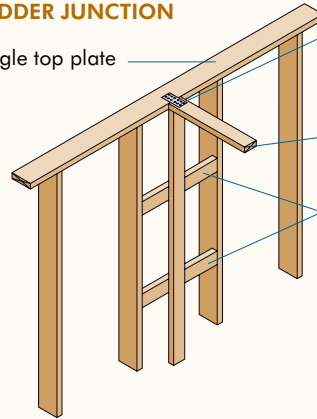

3" x 6" x 0.036" galvanized steel plate (see: PRESCRIPTIVE AND ALTERNATE CONNECTION DETAILS, Figure 6)

Interior wall plate tight to exterior wall plate

2x ladder blocking at 24" o.c. Install blocking with wide face vertical for maximum backing to wall finish materials and for maximum insulation to exterior walls.

JUNCTION FOR CONTINUOUS DRYWALL APPLICATION

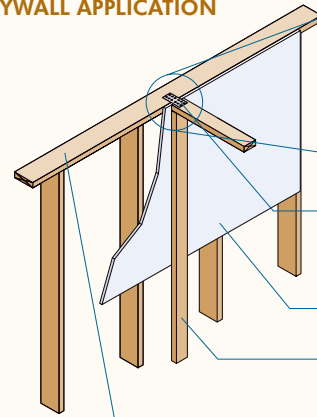

3" x 6" x 0.036" galvanized steel plate (see: PRESCRIPTIVE AND ALTERNATE CONNECTION DETAILS, Figure 6)

Drywall

Interior stud set in 1/2" from exterior wall studs

Single top plate

Detail courtesy of NAHB Research Center.

FIGURE 6

PRESCRIPTIVE AND ALTERNATE CONNECTION DETAILS

LONGITUDINAL TOP PLATE SPLICE

PRESCRIPTIVE CONNECTION

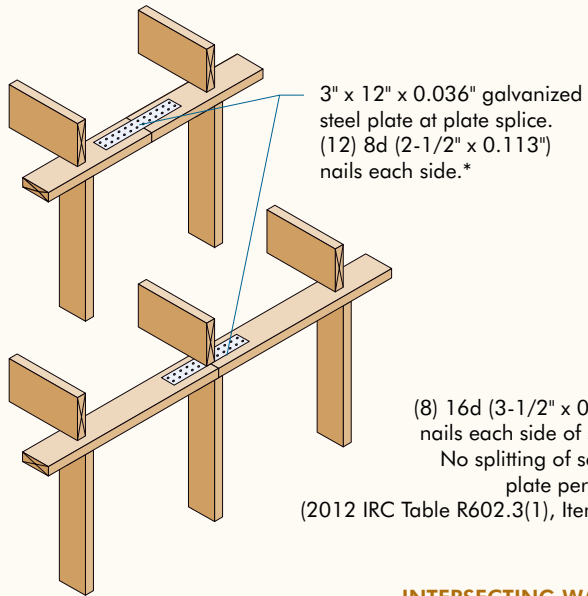

ALTERNATE CONNECTION: SPLICE AT STUD

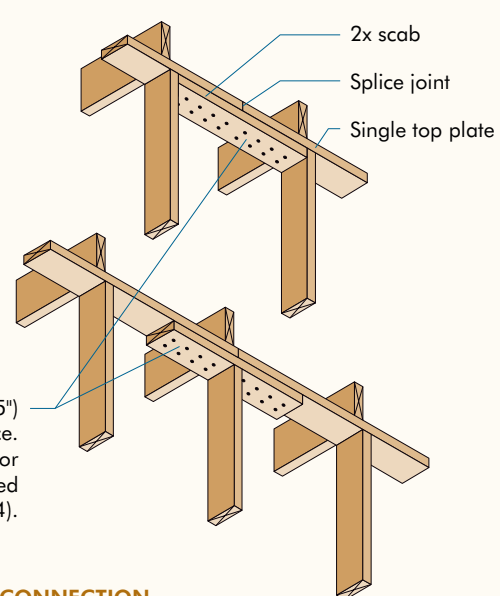

INTERSECTING WALL CONNECTION

PRESCRIPTIVE CONNECTION

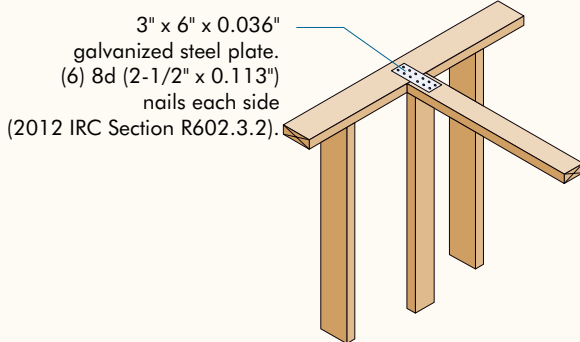

ALTERNATE CONNECTION

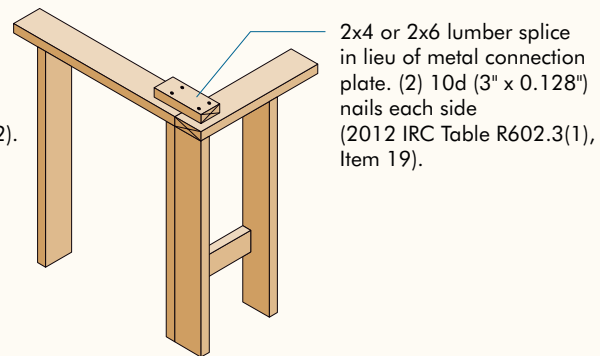
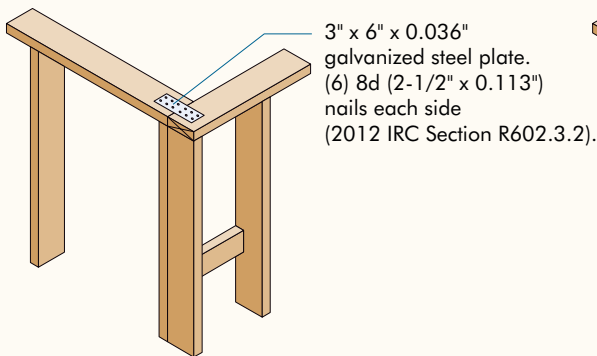
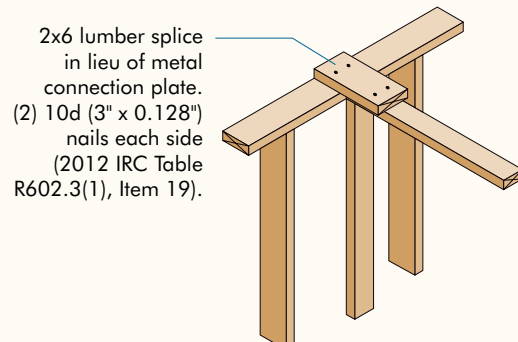

*Plate size and number of fasteners required is greater than prescriptive code requirements for top plate butt-joint splices. This recommendation is based on equivalent performance of 2012 IRC Table R602.3(1), Item 14. Intersecting wall segment top plate splice connections are as per 2012 IRC.

Headers

Advanced framing headers offer increased energy efficiency by replacing framing materials with space for cavity insulation inside the header. Of the various engineered wood and lumber headers shown in Figure 7, single-ply headers provide the greatest amount of cavity insulation space.

Advanced framing headers are sized for the loads they carry and are often installed in single plies rather than double. Sizing for single-ply lumber headers is covered prescriptively in the 2012 IRC Table R602.7.1. Single-ply engineered wood headers may be calculated based on tributary loads applied to the header: determine the live load and total load in pounds-per-linear-foot and refer to a published standard, such as the American Wood Council's *Wood Frame Construction Manual (WFCM) for One- and Two-Family Dwellings*.

Headers at openings in non-load-bearing walls are not required (Figure 8). The opening top plate may be a single member installed flat at the top of the rough opening. Cripple studs are installed between the opening top plate and wall top plate; however, these can be eliminated where the distance from the header to top plate is less than 24 inches (unless required for vertical seams in wall finish materials).

Prefabricated insulated structural components that simplify construction, such as insulated headers and insulated corners, are becoming commonly available.

FIGURE 7

ENGINEERED WOOD AND LUMBER HEADERS

2012 IRC Section R602.7.1

SINGLE-PLY HEADER

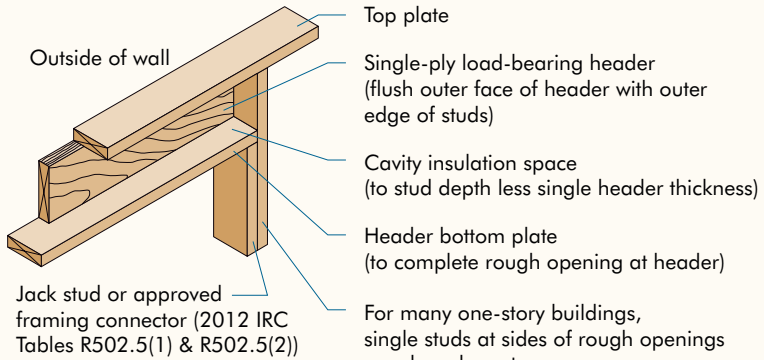

For many one-story buildings, single studs at sides of rough openings may be adequate. See 2012 IRC Table R502.5(1).

LARGE OPENING SINGLE HEADERS

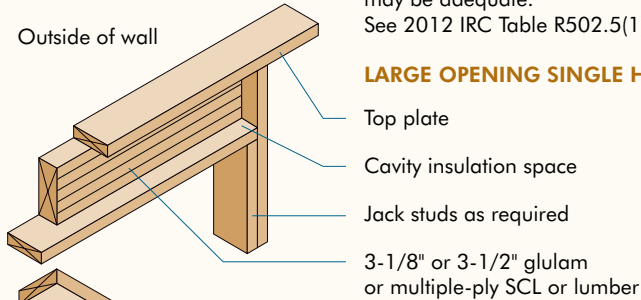

APPROVED FRAMING CONNECTOR OPTION (SINGLE- OR DOUBLE-PLY HEADERS)

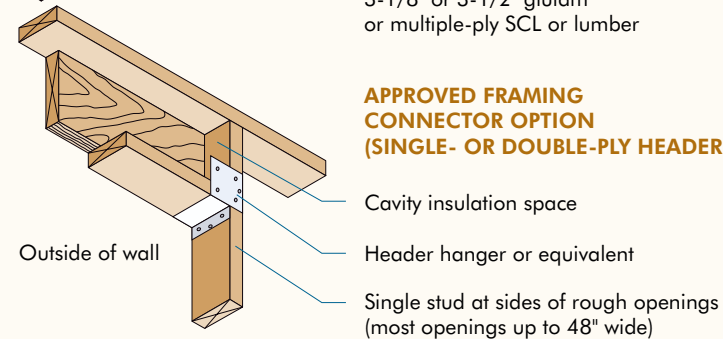
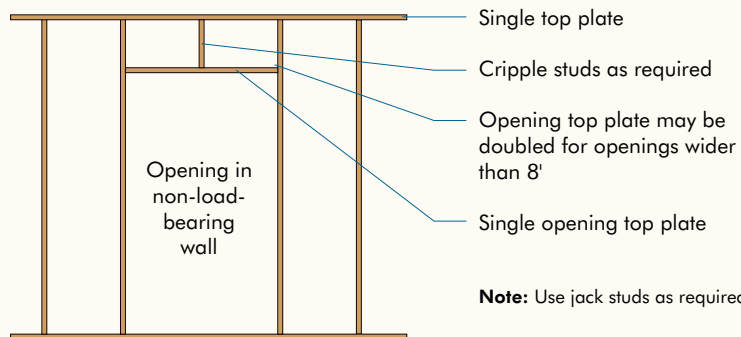

FIGURE 8

OPENING IN NON-LOAD-BEARING WALLS

Conventional headers not required



Wood Structural Panel Box Headers

Site-built wood structural panel box headers may be used as load-bearing headers in exterior wall construction, when built in accordance with 2012 IRC Figure R602.7.2 *Typical Wood Structural Panel Box Header Construction* and Table R602.7.2 *Maximum Spans for Wood Structural Panel Box Headers*. Typically built with 15/32 Performance Category wood structural panel sheathing installed over minimum 2x4 framing, wood structural panel box headers provide more cavity insulation space than dimension lumber headers. Types of wood structural panel box headers are shown in Figure 9.

Wood structural panels can be installed on one side (panel installed on the exterior side) or both sides of the header. In most cases, one-sided is the best option (if meeting the structural requirements specified in the IRC Table) because installation of interior finishes may be impaired by wood structural panels on the interior side of the wall. On the exterior side, wood structural panel box headers are a perfect marriage with continuous wood structural panel wall sheathing.

2012 IRC Table R602.7.2 allows a 15-inch-high one-sided wood structural panel box header to span 4-foot-wide openings for homes up to 28-foot wide, and 3-foot-wide or narrower openings for homes up to 32 feet wide in single-story construction with a clear-span truss roof or two-story construction with floor and roof supported by interior bearing walls. Openings up to 4-foot wide require only a single stud at the sides of the rough opening, eliminating the need for jack studs and thereby providing another opportunity to replace framing members with cavity insulation.

Where nominal ceiling height is 8 feet or higher, an overall header height of 15 inches allows for the installation of 6-foot 8-inch interior and exterior doors.

FIGURE 9

WOOD STRUCTURAL PANEL BOX HEADER FOR LOAD-BEARING WALLS

The top and bottom plates of the wood structural panel box header shall be continuous with no vertical joints in the wood structural panel over opening. For construction details and maximum spans, see 2012 IRC Section R602.7.2, Figure R602.7.2 and Table R602.7.2.

TWO-SIDED WOOD STRUCTURAL PANEL BOX HEADER

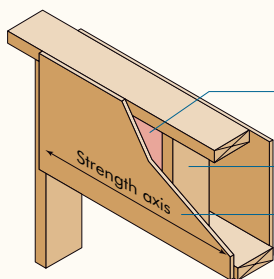

ONE-SIDED WOOD STRUCTURAL PANEL BOX HEADER

Cripple studs on stud layout
Min. 15/32 Performance Category wood structural panel or thicker
Header bottom plate (to complete rough opening at header)

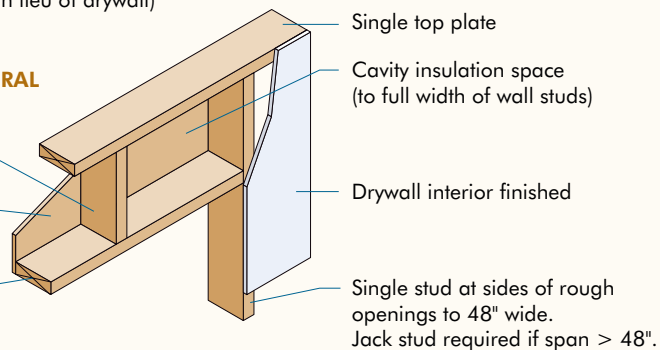
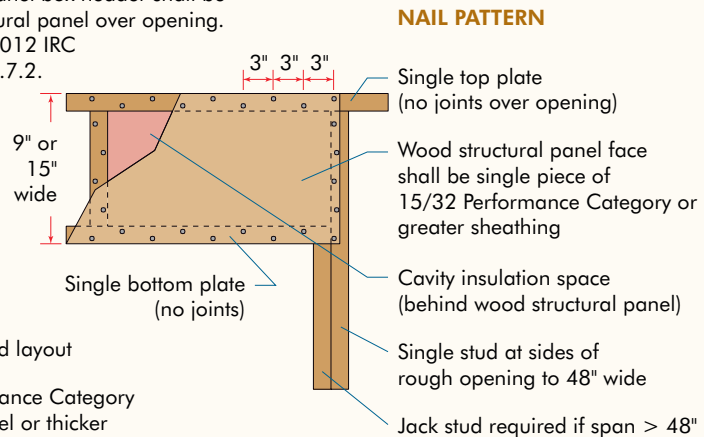

Notes:

1. Framing fastening per code.
2. For engineered box headers with wood structural panels, refer to *Nailed Structural-Use Panel and Lumber Beams, Form Z416*.

Openings

The placement of openings in load-bearing walls and the layout of framing members above openings have a significant impact on header sizing for advanced framing, as shown in Figure 10.

Excessive common studs beside window openings and excessive jack studs and redundant cripple studs above or below openings are often unnecessary (unless specific to the installation of a fixture) and occupy cavity space that could otherwise be filled with additional insulation.

Jack studs – the studs that support headers – may be eliminated where a single jack stud is prescribed by the 2012 IRC Table R502.5(1) and Table R502.5(2) or an approved connector (such as a header hanger) connects the header to the full-height stud at the side of the rough opening, as shown in Figure 7.

FIGURE 10

ROUGH OPENING PLACEMENT

The placement of openings in load-bearing walls and the layout of framing members above openings have significant impact on header sizing for advanced framing.

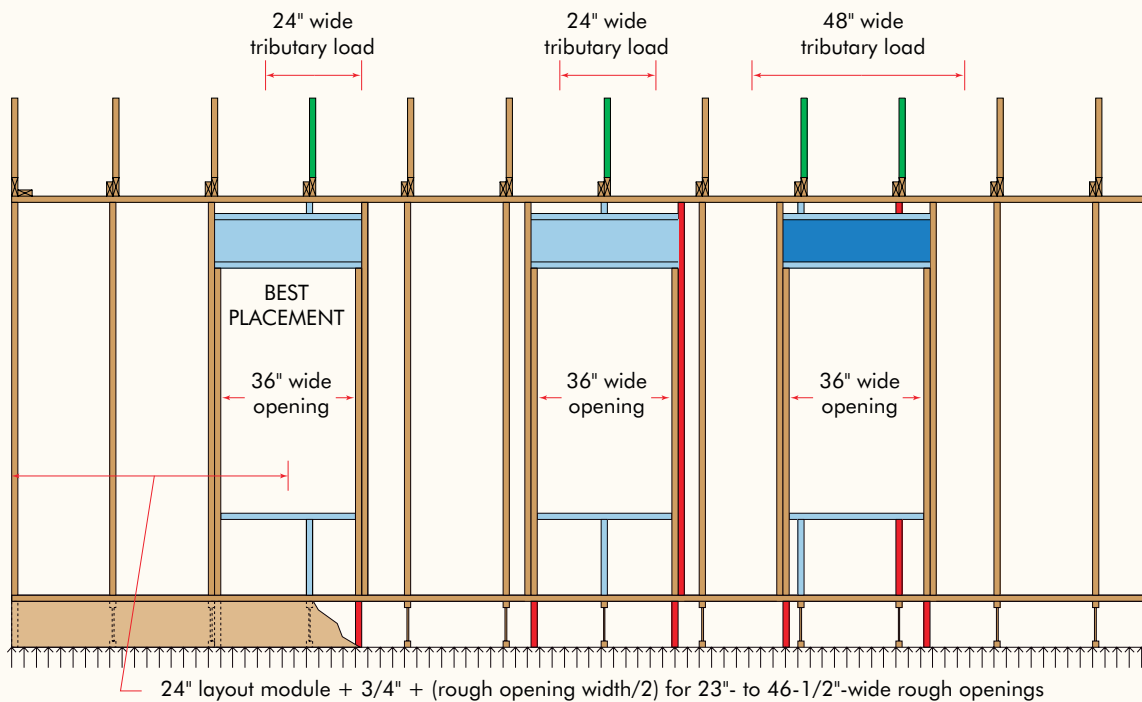

Continuous bearing as provided by load-bearing sill beam or foundation wall.

- Minimum required materials to frame rough opening
- Structure above imposing tributary loads on header
- Potential increased header size — increased load from structure above
- Excess materials due to inefficient opening placement

Note: Jack studs may not be required if using wood structural panel headers (as shown in Figure 9).

The number of full-height studs required at the sides of an opening is not specified in the 2012 IRC, but it is included in *The Wood Frame Construction Manual (WFCM) for One- and Two-Family Dwellings, 2012 Edition*.

2012 WFCM 3.4.1.4.2 Full height studs... *The minimum number of full height studs at each end of the header shall not be less than half the number of studs replaced by the opening, in accordance with Table 3.23C.*

Exception: *The minimum number of full height studs at each end of the header shall be permitted to be reduced in accordance with Table 3.23D...*

Table 3.23D of the 2012 WFCM specifies that, for areas with up to 150 mph (3 second gust) design wind velocity, a single full-height stud is required at each end of a header above openings of up to 48-inches wide when studs are spaced 24 inches on center, subject to stud length and grade limitations.

Blocking

Advanced framing techniques minimize blocking and bridging except where necessary, such as when supporting braced wall panel joints. Where additional framing elements are required for the installation of fixtures or the reinforcement of finish materials, blocking between studs or besides studs provides more space for insulation inside the wall cavity than the installation of additional full-height studs.

2x horizontal blocking (installed perpendicular to the studs) can be oriented with either the edge against the sheathing/drywall or the wide face vertical against the sheathing/drywall. Install the blocking with the wide face vertical against the sheathing/drywall for maximum backing to wall finish materials and minimal intrusion into insulatable cavity.



2x horizontal blocking between studs can be oriented with either the edge against the sheathing/drywall or the wide face vertical against the sheathing/drywall. Both options are shown.

Metal Hardware

Straps and anchors are often required in the structural frame design to resist uplift and lateral wind loads or seismic forces, but metal hardware causes thermal bridging. A thermal bridge occurs when heat is transferred through a building component at a higher rate than the transfer through the surrounding envelope. Since the thermal conductivity of metal is hundreds of times greater than that of wood, the reduction or elimination of metal straps and anchors from the thermal envelope (as permitted by structural requirements) can translate to reduced heat loss.

When framing members are vertically aligned to create a direct load path – in which loads are directly transferred through the framing members (Figure 13) – the studs above the top plate should be strapped or anchored to the studs directly below. Making this connection with wood structural panel sheathing instead of metal connectors can reduce thermal bridging and lower hardware costs. For more information, refer to *APA System Report: Design for Combined Shear and Uplift from Wind*, Form SR-101.

SINGLE TOP PLATES

Single top plate construction requires that all members above the top plate are stack framed (vertically aligned with the members directly below) with a maximum alignment offset tolerance of 1 inch (Figure 11). This requirement applies to roof trusses, rafters, and second-story floor joists when single top plates are used (Figure 13).

There is no offset limitation for placement of members bearing on double top plates when 2x6 studs at 24 inches on center are used.

Ceiling and Roof Framing

Spacing ceiling joists and rafters 24 inches on center can increase material efficiency in ceiling and roof frame construction.

Where attic storage is limited and mechanical equipment is not required, ceiling joists over insulated or conditioned spaces can be located 24 inches on center in accordance with 2012 IRC Table R802.4(1) *Ceiling Joist Spans For Common Lumber Species*.

The installation of ceiling joists immediately beside rafters at 24 inches on center at the top plate provides for a positive member connection as well as the alignment of the rafters and joists with the 24-inch on center wall studs below. In such cases, the permitted framing alignment offset tolerance for single top plate wall construction is 1 inch (Figure 11). As both the rafter and ceiling joist are load-bearing and attached to each other, the 1-inch tolerance is measured from the common edge.

Uplift resistance can be added to the roof framing by anchoring the trusses to the top plate through the nailing of continuous wood structural panel sheathing or the use of metal connectors fastened directly to the raised heel portion of a truss, provided that the top plate is anchored to the members below with continuous wood structural panel wall sheathing (Figure 12).

FIGURE 11

PERMITTED FRAMING ALIGNMENT OFFSETS - SINGLE TOP PLATES

2012 IRC Section R602.3.2 Top plate. Wood studs shall be capped with a double top plate...

Exception: A single top plate may be installed in stud walls provided the plate is adequately tied at joints (see: PRESCRIPTIVE AND ALTERNATE CONNECTION DETAILS, Figure 6)... provided the rafters or joists are centered over the studs with a tolerance of no more than 1 inch (25mm)...

PRESCRIPTIVE MEMBER PLACEMENT FOR SINGLE TOP PLATE WALL CONSTRUCTION

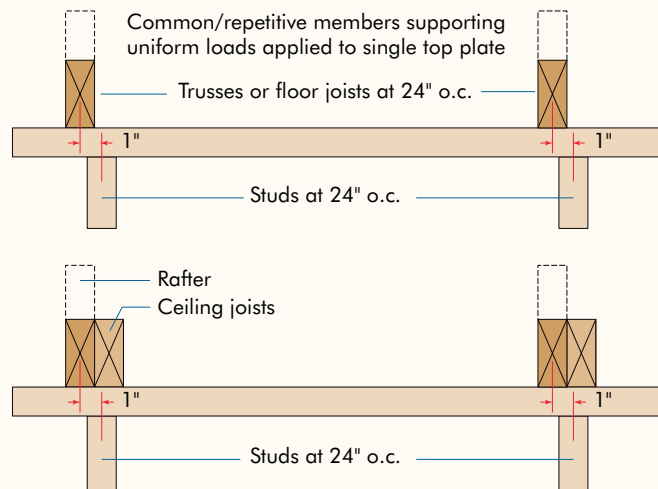
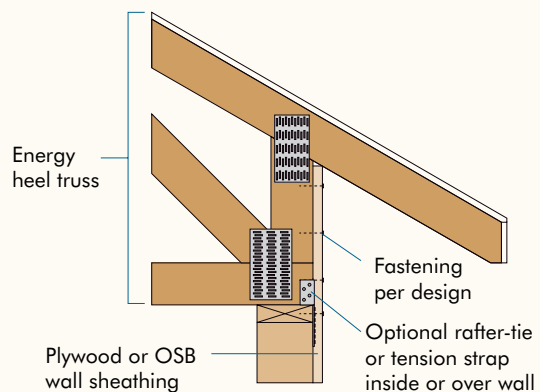

FIGURE 12

ENERGY HEEL TRUSS TO WALL

WOOD STRUCTURAL PANEL OVERLAP



Ensure correct fastening of sheathing to top plate per shear wall, wall bracing, or combined shear and uplift requirements.*

*See rafter-tie manufacturer's instructions for installation of strap over sheathing and into framing.

The 2012 IECC (International Energy Conservation Code) Section 402.2.1 *Ceilings with attic spaces* allows a reduction in the prescriptive attic insulation requirements provided that the uncompressed depth of attic insulation extends over the wall top plate. When energy heel (or raised heel) trusses are used to satisfy this requirement, uncompressed R30 insulation is deemed to satisfy R38 requirements and uncompressed R38 insulation is deemed to satisfy R49 attic insulation requirements. Energy heel roof construction requires an insulation depth of 10 inches for most R30 batt, loose-fill fiberglass or cellulose insulation, and a depth of roughly 12 inches for R38 insulation.

Single Top Plates and Framing Member Layout

Single top plate construction requires vertical framing alignment, in which framing members are “stacked” to create a direct load path. This approach requires a single – or master – framing layout for all members at all framing levels, as illustrated in Figure 13.

When designing a master framing layout, start with the layout of the roof framing members, which is generally dictated by roof design and geometry, followed by the layout of the framing members below. Although this will be a change in approach for framing carpenters who are accustomed to working up from the foundation, addressing the roof first will simplify load calculation for the designer and maximize material efficiency.

The type of roof design will impact the master framing layout. For example, hip roof design will usually require a different starting point for framing member layout than gable roof design. In hip roof construction, common rafters and hip jack rafters typically layout from the nominal center line intersection of the hip(s) with the ridge. In gable roof construction, common rafter layout typically commences from one of the end walls of the structure.

Framing member layout will also be dictated by the type of roof construction. Truss roofs will often require a different framing member layout than framed roofs.

When trusses are specified, the trusses should be stacked directly above the wall studs. There is no member offset, hence the truss and wall stud layout will be the same.

WALL SHEATHING

The potential for panel buckling between studs increases when stud spacing is widened from 16 to 24 inches on center, especially when the sheathing is subjected to moisture exposure during construction. Although this is not a structural concern, excessive buckling may cause serviceability issues. Therefore, it is imperative that builders pay close attention to the moisture management of wood structural panels on the jobsite in addition to APA recommendations for spacing panels 1/8 inch at panel ends and edges. Additional information on preventing wall sheathing from buckling is provided in *APA Technical Note: Minimize Buckling of Wood Structural Panels*, Form X480.

Wind Resistance and Wall Assemblies

Severe storms, tornadoes and destructive winds produce multiple forces that threaten buildings:

- Lateral forces that push against the building, causing walls to rack out of square and weaken the structure. Seismic events also exert lateral forces on buildings.
- Uplift forces that work against gravity to separate the roof from the walls, the walls from the floor, and the floor from the foundation.
- Inward and outward wind pressures that pull on the cladding and sheathing and can separate sections of the roof and walls from the building, potentially exposing the interior to moisture and air infiltration.

All structures built to the specifications of the 2012 IRC are required to resist these loads, in accordance with Section R301.2.1 *Wind design criteria*. Any effort to meet energy code requirements or increase the energy efficiency of a building must be balanced with structural performance and the structural requirements of the code.

The 2012 IRC specifies regions that are subject to higher wind loads and thus require greater uplift and shear resistance. Buildings in these regions are beyond the scope of the prescriptive code requirements of the IRC and should be designed in accordance with the International Building Code (IBC) or other engineering standards.

While wind loads vary by location, no region is completely immune to the forces of nature. The wall assembly is integral to the structure's resistance to wind loads. When properly designed and constructed, advanced framing in conjunction with continuous wood structural panel wall sheathing provides walls with the strength to safely withstand these forces. Refer to Table 1 for the requirements for wood structural panel wall sheathing used to resist wind pressures, including options for 24-inch on center stud spacing.

FIGURE 13

STACK FRAMING AND 24" O.C. MEMBER SPACING

Framing members are stack framed and vertically aligned to create direct load path.

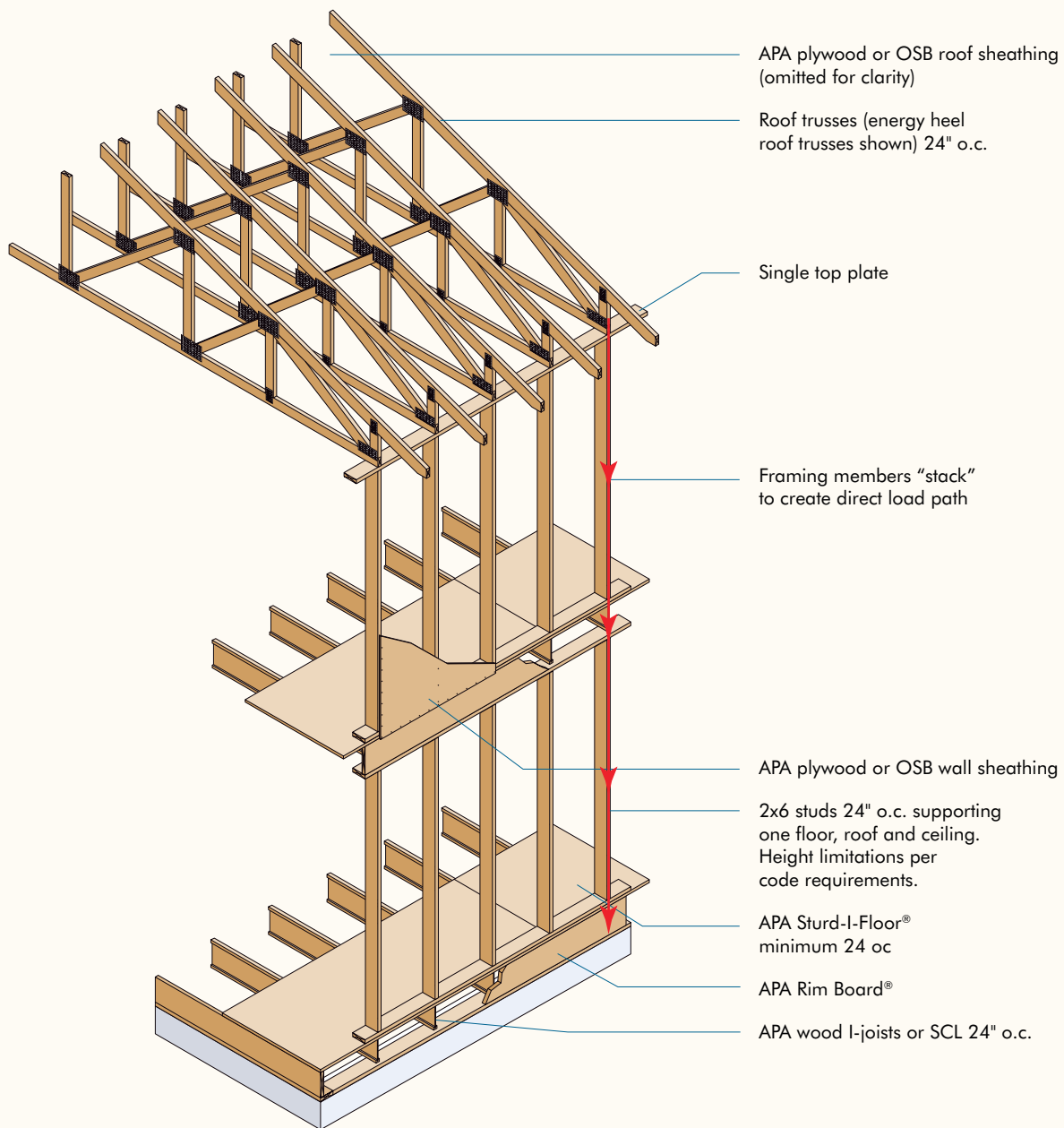

TABLE 1

**2012 IRC TABLE R602.3(3)
REQUIREMENTS FOR WOOD STRUCTURAL PANEL WALL SHEATHING USED TO RESIST WIND PRESSURES^{(a)(b)(c)}**

Minimum Nail Size	Minimum Nail Penetration (in.)	Minimum Wood Structural Panel Span Rating	Minimum Nominal Panel Thickness (in.)	Maximum Wall Stud Spacing (in.)	Panel Nail Spacing		Maximum Wind Speed (mph)		
					Edges (in. o.c.)	Field (in. o.c.)	Wind Exposure Category B C D		
6d Common (2" × 0.113")	1.5	24/0	3/8	16	6	12	110	90	85
8d Common (2-1/2" × 0.131")	1.75	24/16	7/16	16	6	12	130	110	105
				24	6	12	110	90	85

For SI: 1 inch = 25.4 mm, 1 mile per hour = 0.447 m/s.

- (a) Panel strength axis parallel or perpendicular to supports. Three-ply plywood sheathing with studs spaced more than 16 inches on center shall be applied with panel strength axis perpendicular to supports.
- (b) Table is based on wind pressures acting toward and away from building surfaces per 2012 IRC Section R301.2. Lateral bracing requirements shall be in accordance with 2012 IRC Section R602.10.
- (c) Wood structural panels with span ratings of Wall-16 or Wall-24 shall be permitted as an alternate to panels with a 24/0 span rating. Plywood siding rated 16 o.c. or 24 o.c. shall be permitted as an alternate to panels with a 24/16 span rating. Wall-16 and Plywood siding 16 o.c. shall be used with studs spaced a maximum of 16 inches on center.

Wall Bracing

Continuous wood structural panel wall sheathing, when installed in accordance with 2012 IRC Section R602.10 *Wall bracing*, provides builders and designers with the most flexibility in meeting prescriptive bracing requirements. Sheathing walls with plywood or OSB helps the structure to simultaneously resist multiple wind forces, reducing the need for additional force-resisting systems. Rigid foam and other nonstructural sheathing products lack shear/racking strength and require additional wall bracing to meet the code bracing requirements. For more information, refer to APA's *Introduction to Wall Bracing*, Form F430, or visit www.performancewalls.org.

In addition to providing shear strength to the structure, bracing method CS-WSP (continuously sheathed wood structural panel) minimizes the amount of metal straps required for uplift resistance, further reducing thermal bridging and metal hardware costs. Wood structural panel sheathing also provides a withdrawal-resistant nailbase for the attachment of all commonly specified exterior wall finishes, including brick-ties, siding, decorative trim materials and fiber-cement products up to 11 psf. Refer to *APA Technical Topics: Wood Structural Panels Used as Nailable Sheathing*, Form TT-109, for more information.

Other commonly used bracing techniques prescribed by the 2012 IRC, including bracing method LIB (let-in-bracing), require a maximum stud spacing of 16 inches on center or less and are therefore incompatible with some advanced framing techniques.

MORE INFORMATION

Engineered Wood Construction Systems

APA offers a comprehensive set of services and tools for architects, engineers and building designers. If you're looking for detailed product information, training materials or technical assistance, APA can help.

www.apawood.org – APA's website is your link to in-depth design and building support, including a library of more than 400 publications available for instant PDF download or hard-copy purchase.

APA Product Support Help Desk – Staffed by specialists who have the knowledge to address a diverse range of inquiries, the Help Desk can answer your questions about specification and application of APA products, or put you in touch with your nearest engineered wood specialist. Call (253) 620-7400 or send an email to help@apawood.org.

Wall Bracing – Understanding the code requirements for wall bracing can be a challenge, but following them is of critical importance to the structural integrity of a home. APA helps you easily understand, design and build wall bracing systems. The following publications and more information are available at www.performancewalls.org.

- *Introduction to Wall Bracing*, Form F430
- *Brace Walls with Wood*, Form G440

For additional wall bracing information, refer to *A Guide to the 2009 IRC® Wood Wall Bracing Provisions*, authored by APA and the International Code Council® (ICC®). The guide and wall bracing seminars and resources are available at www.iccsafe.org.

Build a Better Home – APA's Build a Better Home program is designed to provide builders and homeowners with the construction guidelines they need to protect their homes against damaging moisture infiltration. Key elements in the building envelope are the roof, walls and foundation. The following publications and more information are available at www.buildabetterhome.org.

- *Build A Better Home: Foundations*, Form A520
- *Build A Better Home: Mold and Mildew*, Form A525
- *Build A Better Home: Roofs*, Form A535
- *Build A Better Home: Walls*, Form A530

Building Codes Referenced in this Guide

- 2012 International Building Code (published by the International Code Council)
- 2012 International Energy Conservation Code (published by the International Code Council)
- 2012 International Residential Code (published by the International Code Council)

Additional References

- 2012 Wood Frame Construction Manual (published by the American Wood Council): www.awc.org/standards/wfcm.html
- ENERGY STAR®: www.energystar.gov
- National Association of Home Builders, ICC 700 National Green Building Standard: www.nahbgreen.org/NGBS
- National Association of Home Builders, NAHB Research Center: www.nahbrc.com
- National Institute of Building Sciences: www.nibs.org
- U.S. Department of Energy, Building Energy Codes Program: www.energycodes.gov
- U.S. Department of Energy, Building Technologies Program: www.eere.energy.gov/buildings
- U.S. Department of Energy, Office of Energy Efficiency and Renewable Energy: www.eere.energy.gov
- U.S. Green Building Council, LEED® Rating System: www.usgbc.org/leed

Acknowledgements

- Tony Mainsbridge, advanced framing consultant, contributed to the recommendations in this guide.



Advanced framing headers, such as single-ply headers, offer increased energy efficiency by replacing framing materials with space for cavity insulation inside the header (see Figure 7).

ABOUT APA

APA is a nonprofit trade association of and for wood structural panel, glulam timber, wood I-joist, structural composite lumber, and other engineered wood product manufacturers. Based in Tacoma, Washington, APA represents approximately 150 mills throughout North America, ranging from small, independently owned and operated companies to large integrated corporations.

APA is a leader in wood-design testing and research. APA's 42,000-square-foot Research Center is staffed with an experienced corps of engineers, wood scientists, and wood-product technicians. Their expertise plays an important role in producing panel and engineered wood systems that meet the industry's highest performance standards and braced-wall designs that promote the structural safety of building construction. For our latest information in building strong, safe and durable structures, visit www.apawood.org.



Advanced Framing Construction Guide

We have field representatives in many major U.S. cities and in Canada who can help answer questions involving APA trademarked products. For additional assistance in specifying engineered wood products, contact us:

APA HEADQUARTERS

7011 So. 19th St. ■ Tacoma, Washington 98466
(253) 565-6600 ■ Fax: (253) 565-7265

PRODUCT SUPPORT HELP DESK

(253) 620-7400 ■ help@apawood.org

DISCLAIMER

The information contained herein is based on APA – The Engineered Wood Association’s continuing programs of laboratory testing, product research, and comprehensive field experience. Neither APA, nor its members make any warranty, expressed or implied, or assume any legal liability or responsibility for the use, application of, and/or reference to opinions, findings, conclusions, or recommendations included in this publication. Consult your local jurisdiction or design professional to assure compliance with code, construction, and performance requirements. Because APA has no control over quality of workmanship or the conditions under which engineered wood products are used, it cannot accept responsibility for product performance or designs as actually constructed.



www.apawood.org



Form No. M400A/Revised September 2014/0200



REPRESENTING THE ENGINEERED WOOD INDUSTRY