

AmDeck™ Technical & Installation Manual



Our Products
stronger every day

Preface

As North America's leader in ICF wall products, Amvic Building System now also offers a complementary Expanded Polystyrene (EPS) floor and roof system that is unmatched in the industry. In late 2005, Amvic launched the innovative NEW AmDeck™ Floor & Roof System, which is a modular, lightweight, stay-in-place form for the construction of concrete floors and roofs. The system is perfectly suited for use with Insulated Concrete Form (ICF) construction, but can also be used independently with other structural systems like steel and concrete framing. AmDeck™ is backed-up by Amvic's renowned customer service and technical support and is available through Amvic's extensive distributor network across North America.

If any of your questions or concerns are not completely addressed in this manual, please feel free to contact us and our staff will be happy to answer your questions. In addition, Amvic's in-house engineering department is always available for any technical support that may be required.

Technical Support:

Please contact us for any inquiries pertaining to information included in this manual, or if you require any other technical assistance.

Technical Support 1 (877) 470-9991 (toll free)
1 (416) 410-5674 ext. 129

Amvic Website

The Amvic website is updated regularly with the most current news, including testing reports, technical bulletins and evaluation reports. This technical and installation manual is posted on the website.

Amvic website – www.amvicsystem.com



Disclaimer

This document is provided for informational purposes only. The information contained in this document represents the current views of Amvic Inc. on the issues discussed as of the date of publication. These opinions, as expressed, should not be interpreted to be a commitment on the part of Amvic Inc. and cannot guarantee the accuracy of any information presented after the date of publication. The user assumes the entire risk as to the accuracy and the use of this document.

This manual provides a basic guide for the installation of the AmDeck™ Floor and Roof System and is intended to supplement, rather than replace, the basic construction knowledge of the construction professional. All installations of AmDeck™ must be in accordance with all applicable building codes and/or under the guidance of a licensed professional engineer. In all cases, applicable building code regulations take precedence over this manual.

INFORMATION CONTAINED IN THIS DOCUMENT IS PROVIDED “AS IS”, WITHOUT ANY WARRANTY OF ANY KIND, EITHER EXPRESSED OR IMPLIED, INCLUDING, BUT NOT LIMITED TO, THE IMPLIED WARRANTIES OF MERCHANTABILITY, FITNESS FOR A PARTICULAR PURPOSE, AND FREEDOM OF INFRINGEMENT.



Table of Contents

	PAGE
Part 1 – Introduction	1
1.1 – AmDeck™ Floor & Roof System	1
1.2 – Product Benefits	3
1.3 – Applications	4
Part 2 – Dimensions & Packaging	5
2.1 – Product Dimensions	5
2.2 – Product Packaging	6
2.3 – Concrete Volume Calculator	7
Part 3 – Tools, Material & Accessory Requirements	9
3.1 – Tools for AmDeck™ Installation	9
3.2 – Tools for Concrete Pour	9
3.3 – Tools for Utility Installation	10
3.4 – Materials List	10
Part 4 – Construction Overview	11
Part 5 – Engineering Requirements	17
5.1 – Formworks, Shoring and Bracing	17
5.2 – AmDeck™ Floor/Roof Structural Requirements	19
5.3 – Typical Steel Reinforcement for AmDeck™	20
Part 6 – Utility and Service Installation	23
6.1 – Overview	23
6.2 – Utility and Service Types	23
6.3 – Longitudinal Utility and Service Installations	25
6.4 – Transverse Utility and Service Installations	28
6.5 – Utility and service conduits/pipes embedded in Top Slab	31
6.6 – Vertical Utility and Service Penetrations and Openings	32
6.7 – Large Openings in the AmDeck™ System	35
6.8 – Large sized Duct System Installation	37
6.9 – Special Installations on AmDeck™: Attaching the Floor Boot	41
6.10 – AmDeck™ and Radiant Floor Heating Installation	42



Part 7 – The Installation Process	45
7.1 – Overview	45
7.2 – Safety and Emergency Planning	45
7.3 – Construction Planning	47
7.4 – Installing the forms	48
Part 8 – Concrete Placement	71
8.1 – Overview	71
8.2 – Pre-pour Checklist	71
8.3 – Safety tips for handling and placing concrete	72
8.4 – Concrete specifications for AmDeck™	73
8.5 – Concrete Placement	73
8.6 – Consolidating the Concrete	76
8.7 – Using Concrete Vibrators	78
8.8 – Finishing the Concrete Pour	81
8.9 – Concrete Curing	84
Part 9 – Interior & Exterior Finishes	87
9.1 – Overview	87
9.2 – Exterior Finishing (applied to the concrete side)	87
9.3 – Interior Finishing (Soffit Side)	89
9.4 – Roof finishes	94



Part 1 – Introduction

1.1 – AmDeck™ Floor & Roof System

The AmDeck Floor & Roof System™ is a modular stay-in-place form, made of Expanded Polystyrene (EPS) for the construction of concrete floors and roofs. The decking formed by AmDeck™ is a one-way reinforced concrete joist construction type (a.k.a one-way ribbed floor). The use of small standardized, lightweight units, make the system much easier to use and handle than competing products. When installed properly, the system provides structural strength through reinforced concrete and insulation through EPS.



Figure 1.1 – AmDeck™ Form

The EPS used in the AmDeck Floor and Roof System™ has a density of 1.5 pcf (24 kg/m³) and is in compliance with ASTM C578 and CAN/ULC S701 type II. The EPS is made from BASF BF or BFL beads, with a maximum flame spread and smoke developed of 25 and 450 respectively, as per ASTM E 84, and flame spread and smoke developed of 210 and 400-450, as per CAN/ULC-S102.2.

The AmDeck™ forms are reinforced with injection molded high impact polypropylene webs. As a result, the forms are able to carry construction loads comfortably without being damaged or the EPS fracturing.





Figure 1.2 – AmDeck™ Propylene Web



Figure 1.3 – Propylene Web embedded in EPS

In addition, AmDeck™ utilizes 10 inch (254 mm), lightweight steel framing joists which carry the temporary construction loads and act as furring strips for interior drywall finishing.



Figure 1.4 – Lightweight steel framing joists for the AmDeck™ floor and roof system



1.2 – Product Benefits

Enables Shoring Spans up to 20 ft (6 m)

AmDeck™ implements full 10 inch deep (254 mm), lightweight steel joists with design thicknesses of 0.0566 inch (1.4 mm), 0.0713 inch (1.8 mm), and 0.1017 inch (2.6 mm) (formerly referred to as gauge 16, 14 and 12, respectively). The joists support temporary construction loads until the poured concrete gains its specified strength. As a result, shoring can be placed up to 20 ft (6 m) on center, (depending on topping slab thickness and allowable deflection tolerances) which substantially reduces shoring requirements and overall construction costs when compared to competing products.

Small/Compact Units

AmDeck™ comes in standardized, small, lightweight modular units, which make the system easier to handle and use. The modular units are assembled on-site to construct the floor or roof span in an easy and fast manner. AmDeck™ forms can also be easily cut from both orthogonal directions to fit a specific span or width, making this system extremely flexible, in comparison to competing products.

Provides Structure

One-way concrete floor/roof joists which are formed by AmDeck™ can span up to 30 ft (9.1 m) using normal concrete mixes and conventional reinforcing steel. Spans of greater than 30 ft (9.1 m) can be achieved using higher strength concrete and post-tensioned reinforcing cable strands.

Reduces Costs

AmDeck™ is a fully reversible system which reduces labor costs, installation time, allows for multiple installation teams and minimizes material wastage. In addition, AmDeck™ is a “ready to finish” system that requires no additional furring strips, saving both time and money.



High Performance

When used for roofs, AmDeck™ provides protection against fire and extreme weather such as tornadoes and hurricanes. In addition, the EPS used in AmDeck™ provides continuous thermal insulation and considerably reduces the amount of sound transmission between floors.

1.3 – Applications

AmDeck™ is highly versatile and can be used for a variety of applications in all sectors of the construction industry including residential, commercial and institutional. The system can be used to create floors, flat roofs, pitched roofs, balconies and cantilevers (subject to engineering review and design). In addition to being fully compatible with ICF walls, AmDeck™ can also be used with structural concrete and steel framing systems.



Part 2 – Dimensions and Packaging

2.1 – Product Dimensions

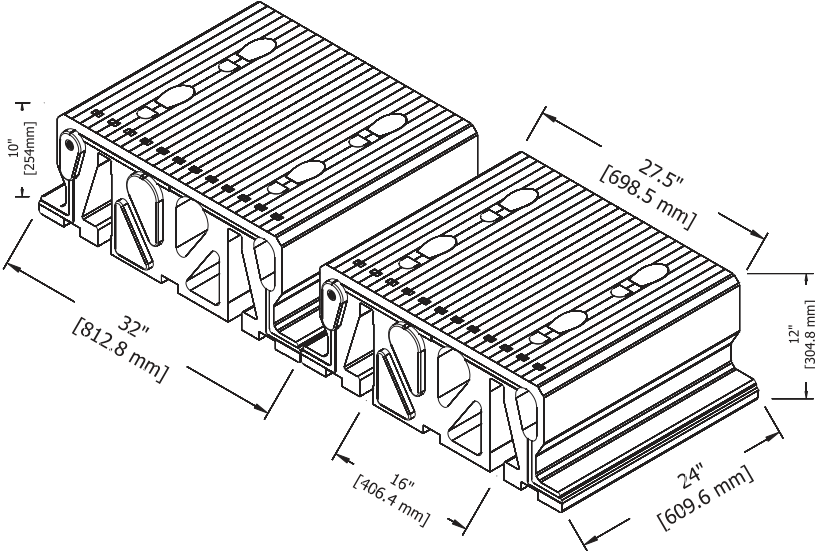

Figure 2.1 – Isometric illustration of AmDeck™ forms

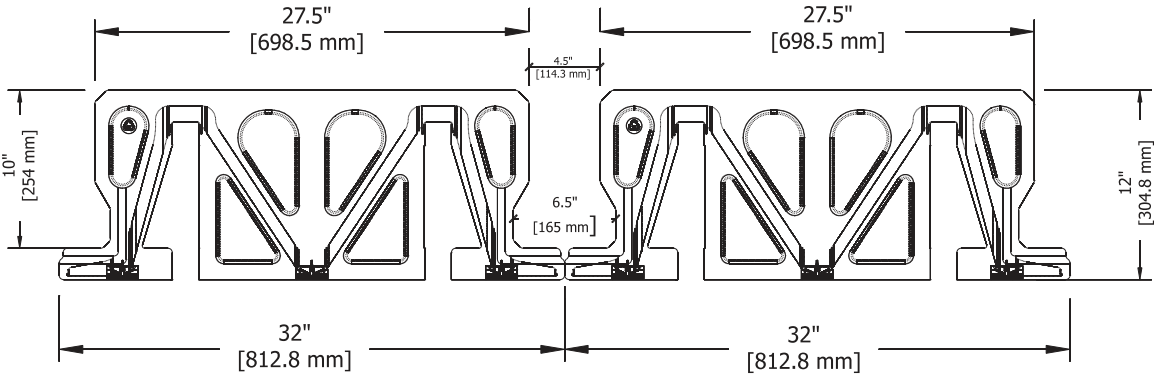

Figure 2.2 – Cross-section of AmDeck™ forms



2.2 – Product Packaging

To maximize transport efficiency, two packaging alternatives are available.

Unit Weight (lbs)	Unit Weight (kg)	Quantity	Total Weight (kg)	Total Weight (lbs)	Package Dimensions (in)	Package Dimensions (cm)
8.07	3.636	8	29.1	64.58	48.5x51.5x27	123.2x130.8x68.6
8.07	3.636	10	36.36	80.72	60.5x51.5x27	153.7x130.8x68.6

Table 2.1 – AmDeck™ Product Packaging



2.3 – Concrete Volume Calculator

In order to estimate the concrete volume used for the AmDeck floor & roof system™ flooring system, please refer to the AmDeck™ Concrete Calculator, Tables 2.2 – 2.7 below.

AmDeck™ Concrete Calculator Volume / Unit Area Imperial		
Concrete Topping Slab Thickness	Concrete Volume	Cover Area
2"	0.0112 cu.yd	1 sq.ft.
2.5"	0.0128 cu.yd	1 sq.ft.
3"	0.0143 cu.yd	1 sq.ft.
3.5"	0.0158 cu.yd	1 sq.ft.
4"	0.0174 cu.yd	1 sq.ft.
4.5"	0.0189 cu.yd	1 sq.ft.
5"	0.0204 cu.yd	1 sq.ft.

Table 2.2 – Volume/Unit Area (Imperial)

AmDeck™ Concrete Calculator Volume / Unit Area Imperial		
Concrete Topping Slab Thickness	Concrete Volume	Cover Area
2"	1 cu.yd	89.37 sq.ft.
2.5"	1 cu.yd	78.54 sq.ft.
3"	1 cu.yd	70.05 sq.ft.
3.5"	1 cu.yd	63.21 sq.ft.
4"	1 cu.yd	57.60 sq.ft.
4.5"	1 cu.yd	52.89 sq.ft.
5"	1 cu.yd	48.90 sq.ft.

Table 2.3 – Area/Unit Volume (Imperial)

AmDeck™ Concrete Calculator Volume / Unit Area Metric		
Concrete Topping Slab Thickness	Concrete Volume	Cover Area
2"	0.0921 m ³	1 m ²
2.5"	0.1048 m ³	1 m ²
3"	0.1175 m ³	1 m ²
3.5"	0.1302 m ³	1 m ²
4"	0.1429 m ³	1 m ²
4.5"	0.1556 m ³	1 m ²
5"	0.1683 m ³	1 m ²

Table 2.4 – Volume/Unit Area (Metric)

AmDeck™ Concrete Calculator Volume / Unit Area Metric		
Concrete Topping Slab Thickness	Concrete Volume	Cover Area
2"	1 m ³	10.86 m ²
2.5"	1 m ³	9.54 m ²
3"	1 m ³	8.51 m ²
3.5"	1 m ³	7.68 m ²
4"	1 m ³	6.99 m ²
4.5"	1 m ³	6.42 m ²
5"	1 m ³	5.94 m ²

Table 2.5 – Area/Unit Volume (Metric)

AmDeck™ Concrete Calculator Volume / Unit Area Imperial / Metric		
Concrete Topping Slab Thickness	Concrete Volume	Cover Area
2"	0.0086 m ³	1 sq.ft.
2.5"	0.0098 m ³	1 sq.ft.
3"	0.0109 m ³	1 sq.ft.
3.5"	0.0121 m ³	1 sq.ft.
4"	0.0133 m ³	1 sq.ft.
4.5"	0.0145 m ³	1 sq.ft.
5"	0.0156 m ³	1 sq.ft.

Table 2.6 – Volume/Unit Area (Imperial/Metric)

AmDeck™ Concrete Calculator Volume / Unit Area Imperial / Metric		
Concrete Topping Slab Thickness	Concrete Volume	Cover Area
2"	1 m ³	116.87 sq.ft.
2.5"	1 m ³	102.70 sq.ft.
3"	1 m ³	91.60 sq.ft.
3.5"	1 m ³	82.67 sq.ft.
4"	1 m ³	75.32 sq.ft.
4.5"	1 m ³	69.17 sq.ft.
5"	1 m ³	63.95 sq.ft.

Table 2.7 – Area/Unit Volume (Imperial/Metric)





Part 3 – Tools, Materials and Accessory Requirements

3.1 – Tools for AmDeck™ Installation

- Chain saw
- Sawsall
- Tape measure
- 4 ft level or straight edge
- String line
- Cordless drills
- Hammer
- Protective gloves
- Eye and ear protection
- Foam gun
- Wire tie tool
- Rebar bender/cutter
- Gas quick cut saw or electric cut off saw
- Ramset (optional for shooting joists to wall)
- Shoring/Bracing
- Felt tip marker

3.2 – Tools for Concrete Pour

- Concrete vibrator
- Rubber gloves
- Hard hats
- Concrete finishing tools
- Flat shovels for spill clean up
- Protective eye and ear equipment
- Laser Level



3.3 – Tools for Utility Installation

- Hot knife
- Foam and foam gun
- Electric chain saw
- Reciprocating saw
- Hand saw
- Drill
- Hole saw
- Marking pens

3.4 – Materials List

- Tie wire in rolls and pre-made reinforcing steel tie loops
- Sleeves for utility penetrations
- Ramset (optional)
- Concrete screws, TAPCON brand or equivalent (optional)
- Foam and foam adhesive
- Rebar stand offs
- Self tapping screws
- Strapping
- AmDeck™ End Covers



Part 4 – Construction Overview

Step 1

Install steel joists with a centerline spacing of 16 inches (406.4 mm) apart, resting on the supporting structure (walls, concrete beams or structural steel beams).

Step 2

Place one form at each end of the joists, then begin laying the remaining forms from one side, working towards the other.



Figure 4.1 – Laying out forms



Step 3

Erect shoring as specified by engineering/code requirements.



Figure 4.2 – Shoring beneath AmDeck™ floor

Step 4

If an Amvic ICF wall has been installed, form the perimeter of the walls to contain the poured concrete. If AmDeck™ will be supported by a concrete girder then form the side walls of the girder and brace adequately before the concrete pour.



Step 5

Seal all seams between forms and all edges using low expansion foam.



Figure 4.3 – Sealing seam between AmDeck™ blocks

Step 6

Install bottom steel reinforcement.

Step 7

Install utility and service sleeves, conduits, pipes, radiant heating and block-outs as required or specified. (Please refer to Part 6 of this manual for details on utility and service installations).



Step 8

Install transverse and longitudinal reinforcing steel in the concrete topping slab as per engineering specifications.



Figure 4.4 – Transverse and longitudinal steel on AmDeck™ for top slab

Step 9

Pour concrete onto forms, ensuring adequate consolidation using a mechanical vibrator.



Figure 4.5 – Consolidating concrete on AmDeck™ using a mechanical vibrator



Step 10

Trowel and finish the concrete surface to the required architectural or engineering specifications.



Figure 4.6 – Finishing concrete surface on AmDeck™





Part 5 – Engineering Requirements

5.1 – Formworks, Shoring and Bracing

5.1.1 - Definitions

The following definitions shall be applied in this section;

- **Architect/Engineer** – The architect, engineer, architectural firm or engineering firm responsible for issuing project plans and specifications or administering the work under the contract documents or both.
- **Contractor/Formwork Engineer** - The person responsible for performing or overseeing formwork design, drawings, erection and removal.
- **Formwork** – The total system of support for freshly placed concrete, including the mold or sheathing that contacts the concrete and all supporting members, hardware and necessary bracing.
- **Shores** – Vertical or inclined support members designed to carry the weight of the formwork, concrete and construction loads above.
- **Reshores** – Shoring which is placed under a stripped concrete slab or other structural member **after** the original forms and shores/bracing have been removed. This requires the slab to deflect and support its own weight and existing construction loads before the installation of the reshores.
- **Diagonal Bracing** – Supplementary formwork members designed to resist lateral loads.

5.1.2 - Formworks, Shoring & Bracing Standards

All formworks and shoring/bracing shall be designed and installed in compliance with the following standards:

- 1 – **ACI 347** – Guide to formwork for Concrete (USA) or;
- 2 – **CAN/CSA-S2693.3** – Concrete Formwork (Canada)



5.1.3 - Formworks, Shoring & Bracing Responsibility

Although AmDeck™ forms are considered components of the formworks that will contain the freshly poured concrete, other reinforced concrete elements such as beams/girders and columns will need independent conventional formworks.

It is the responsibility of the contractor/formwork engineer to design and erect adequate formworks and shoring/bracing to support all expected loads and to meet required specifications.

For complex structures, such as long span floors, multi-storey or high-rise buildings and post-tensioned AmDeck™ joists, the architect/engineer may be required to review and approve the formworks, shoring/bracing, drawings and calculations prepared by the contractor/formwork engineer. Hence, it is recommended that the following items be clarified in the contract documents:

1. The person responsible for designing the formworks and shoring/bracing.
2. The person responsible for inspecting the formworks and shoring/bracing and when the inspection(s) will be conducted.
3. The reviews and approvals required for:
 - I. Shoring/bracing drawings and calculations
 - II. Shoring/bracing before and during concreting
4. The person responsible for performing the above reviews and approvals.

5.1.4 - Information Required for Formworks Shoring/Bracing Design

The contract documents should include all necessary information about the structure for the contractor/formwork engineer to design adequate formworks and shoring/bracing, including but not limited to, the following:

1. Tolerances for concrete construction required for the finished AmDeck™ floor or roof.
2. Sequence of concrete placement if required.
3. Number and location of all construction joints or expansion/contraction joints.
4. The location and order of erection and stripping of shoring/bracing if critical.
5. All live loads, dead loads and superimposed dead loads for which the AmDeck™ is designed.



6. Amount of camber required for AmDeck™ to compensate for deflection of the concrete joists.
7. Special requirements and provisions in the formworks for post-tensioned concrete joists due to load transfer and movement in the tensioning process.

5.1.5 - Formworks and Shoring /Re-shoring for Multi-Storey Structures

For multi-storey structures, the re-use of shores and formworks for upper consequent floors reduces construction costs. Furthermore, the faster formworks and shores/bracing can move up to the next floor level, the sooner other construction trades can start.

The stripping of formworks and shoring/bracing for these types of structures requires special attention by the contractor/formwork engineer. Formworks and shoring/bracing supporting a fresh concrete floor are in turn supported by a lower floor that was not originally designed to carry such a load. It is therefore crucial to provide re-shoring for a sufficient number of floors, to distribute the imposed construction loads to several floor levels, without causing excessive stress or slab deflections.

5.2 – AmDeck™ Floor/Roof Structural Requirements

5.2.1 – Structural Drawings/Details

The structural design of an AmDeck™ floor or roof MUST be prepared by a licensed professional engineer who is knowledgeable in the design of concrete decking systems.

All AmDeck™ projects MUST have independent structural drawings and design calculations prepared, sealed and signed by an engineer. These drawings are not limited to, but must adequately describe the following:

1. AmDeck™ plan and joist layout for each floor level
2. The adequate number of cross-sections and beam/joist elevations to fully describe:
 - a. Steel reinforcement details in the concrete joists and topping slab.
 - b. Steel reinforcing splicing and development length details.
 - c. Connections to the building structural system.



- d. Number and location of inserts, construction joints, built-in frames for opening penetrations and any other work of other trades that will be attached to, supported by, or penetrate through the AmDeck™ floor or roof.
3. Concrete mix-design specifications.
4. All loads considered in the design of the AmDeck™ system.

5.2.2 - Design Standards

The structural design of an AmDeck™ floor or roof shall comply with the following standards:

1. **ACI-318** - Building Code Requirements for Structural Concrete (USA)
2. **CSA A23.3** - Design of Concrete Structures (Canada)



Important Note

Refer to the CAD details for typical AmDeck™ to beam/wall system connection details.

5.3 – Typical Steel Reinforcement for AmDeck™

The contractor/installer should have a basic knowledge of the typical reinforcement requirements for the AmDeck™ floor and roof system. Figure 5.1 below, illustrates a typical AmDeck™ cross-section and the typical steel reinforcing requirements to be specified by the design engineer.



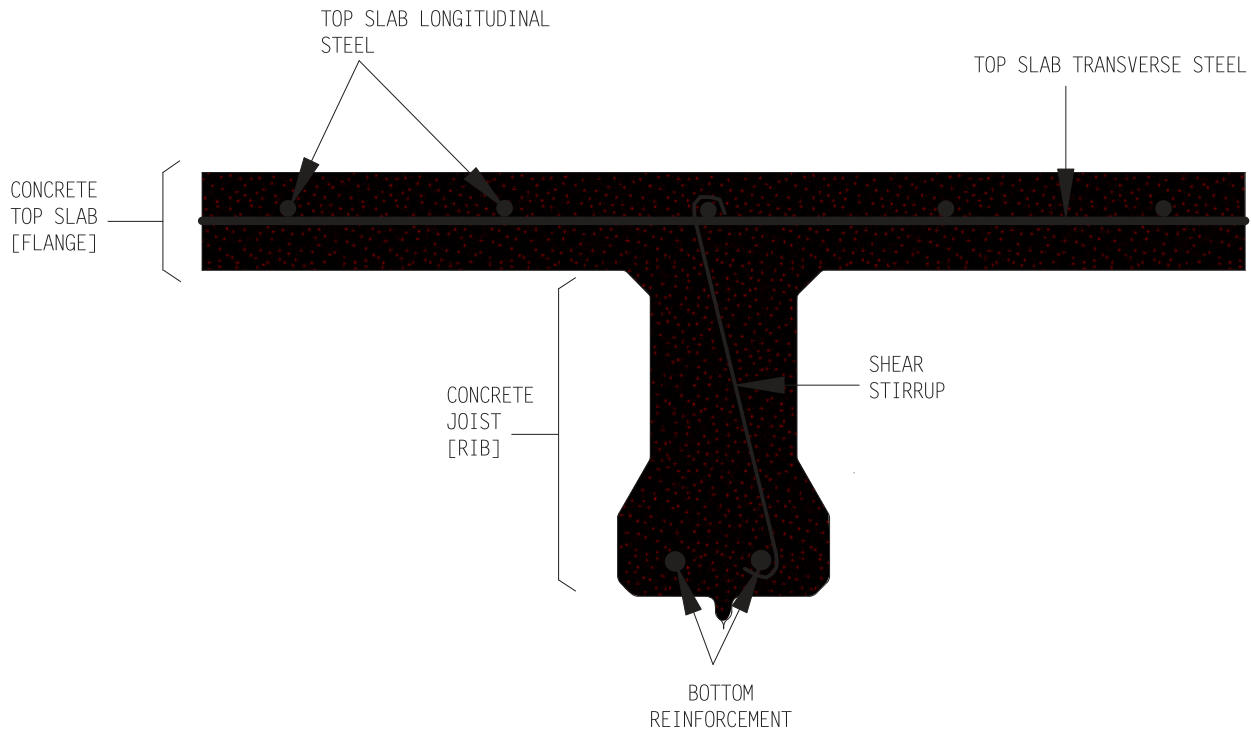

Figure 5.1 – Cross-section of Typical Reinforcing on AmDeck™

The structural design of the AmDeck™ joists will follow the typical design of a T-Section as per ACI 318 or CSA A23.3. The top slab will form the flange of the T-section with an effective flange width of 32 inches (812.8 mm). The flange (top slab) thickness will typically vary between 2 inches – 4.5 inches (50 mm – 115 mm) depending on the engineering design and fire rating requirements. Note that fire-resistance rating, if required, will most likely govern the flange or top slab thickness.

The bell-shaped rib or beam, forms the web portion of the T-section. The web has a minimum width of 4.5 inches (114.3 mm) and flares out to 6.5 inches (165.1 mm) towards the bottom 3 inches (76.2 mm).

Typical steel reinforcing requirements for an AmDeck™ floor or roof system shall include the following:

1 – Bottom Reinforcement

This reinforcement will usually comprise one or two reinforcing bars the size of which is determined by the design engineer. The location of the bottom reinforcement, as the figure illustrates, is within the lower portion of the concrete joist web. The minimum clear cover is 3/4 inch (20 mm); however, Amvic recommends at least 1 inch (25 mm).



2 – Top Slab Transverse Reinforcement

This reinforcement is the main strengthening element in the top slab. The design engineer should specify both the size of the steel bars to be used and the required on-center spacing. The location of the transverse reinforcement should be at mid-depth of the top slab, in order to resist both positive and negative bending moments.

3 – Top Slab Longitudinal Reinforcement

The AmDeck™ floor or roof is basically a one-way concrete joist system. The load on the top slab will always be distributed transversely between the concrete joists. Consequently, longitudinal reinforcement is required only for crack/shrinkage purposes. This reinforcement may be placed either on top or below the top slab transverse steel.

4 – Reinforcing Stirrups

The design engineer may, in some cases, specify shear stirrups, including the size and on-center spacing to be used when the shear capacity of the concrete alone has been exceeded. In such a case, shear stirrups are called for, to increase the shear capacity of the joist.



Part 6 – Utility and Service Installation

6.1 – Overview

Utility and service penetrations need special attention by all parties concerned with the design and construction of an AmDeck™ floor or roof. The design engineer and installer/contractor should have a clear understanding of how to accommodate for utility and service installations. This entails knowing exactly how the associated openings/penetrations/embedments can be implemented when constructing with AmDeck™. Amvic strongly recommends that all service and utility trades carefully review this part of the manual before attempting to execute an actual contract/job.

6.2 – Utility and Service Types

Any residential or commercial structure will need to be properly fitted with utilities and services which will penetrate through, be embedded in, or attached to the AmDeck™ system. The most common types include, but are not limited to, the following:

6.2.1 - Radiant floor heating

Radiant floor heating tubes are generally made either of PVC (polyvinyl chloride) or cross-linked PEX (polyethylene). The diameter of the tubing can range from 1/2 inch OD (12.7 mm) to 1 inch OD (25.4 mm). The most efficient use of radiant floor heating with AmDeck™ is to embed the tubing in the concrete top slab. Please refer to section 6.11 for more details on radiant floor heating installation in an AmDeck™ floor.

6.2.2 - Plumbing

Plumbing pipes and tubing are made from a variety of different materials with the most common ones being PVC, PEX or copper. In general, plumbing can be subdivided into the following categories:

6.2.2.1 - Water Supply Lines

Most water supply lines to sinks, bathtubs/showers, dishwashers, dryers etc. are less than 2 inches OD (50 mm). The pipe sizes for showers, for both hot and cold water, range from 3/4 inch to 1 inch OD (19 mm to 25 mm).



6.2.2.2 - Drainage Pipes

Drainage pipes for bathroom tubs/showers are at least 2 inches OD (50 mm) and for water closets, at least 3 inches OD (76 mm).

6.2.2.3 - Venting Systems

These are a minimum of 1-1/4 inches OD (32 mm) to 4 inches OD (102 mm), depending on the pipe sizes of the drainage system being served.

6.2.3 - Electrical Conduits

Electrical conduits range in size from 1/2 inch OD (12.7 mm) to 6 inches OD (152 mm). They may be metallic or non-metallic, and flexible or non-flexible. The metallic conduits may be made of galvanized or stainless steel. The non-metallic conduits are normally made of PVC.

6.2.4 - Cable

The term “cable” refers to two or more flexible electrical conductors, held together within a fully flexible sheath. Many types of cable exist, such as: coaxial or triaxial cables, power cables, cable heaters, multi-conductor cables etc. They range in diameter from fractions of an inch to several inches.

6.2.5 - HVAC (Heating Ventilating and Air Conditioning)

The modern forced air HVAC system comprises a network of plenums and ducts, made of galvanized sheet metal. A typical HVAC system consists of the following: a plenum lies immediately above the furnace or cooling unit, onto which a main duct or an extended plenum is connected. The main duct and plenum are usually rectangular in cross-section. From the main duct, branch ducts, which can be round, square or rectangular pipes, also made of galvanized sheet metal, supply air to the various rooms in the building. A parallel system of main and branch ducts re-circulates the supplied air from the rooms, back to the furnace. The branch ducts are a minimum of 3 inches OD (76mm), and usually 4 to 6 inches OD (102mm to 152mm).

Similarly, HRVS and ERVS (heat or energy recovery ventilation systems) provide for both intake and return air. Their branch ducts usually range in size from 5 inches to 8 inches OD (127mm to 203mm) width/diameter.



Branch ducts for standard forced air systems penetrate through AmDeck™ vertically, to supply hot/cold air to the rooms through floor vents. HRVS and ERVS ducts also vertically penetrate through AmDeck™, but provide air flow through vents on the wall, rather than through floor vents.

Duct diameters are dependent upon design considerations for heating/cooling capacity to particular rooms. All applicable building codes must be complied with, when installing HVAC systems.

6.2.6 - Fire Sprinkler System

These can range in sizes from 3/4 inch to 3 inches and may be metallic (copper or steel) or non-metallic (ABS, CPVC, PE, and PVC).

6.3 – Longitudinal Utility and Service Installations

Figure 6.1 illustrates the orientation of utility and services that are installed longitudinally i.e. parallel to the steel joists.

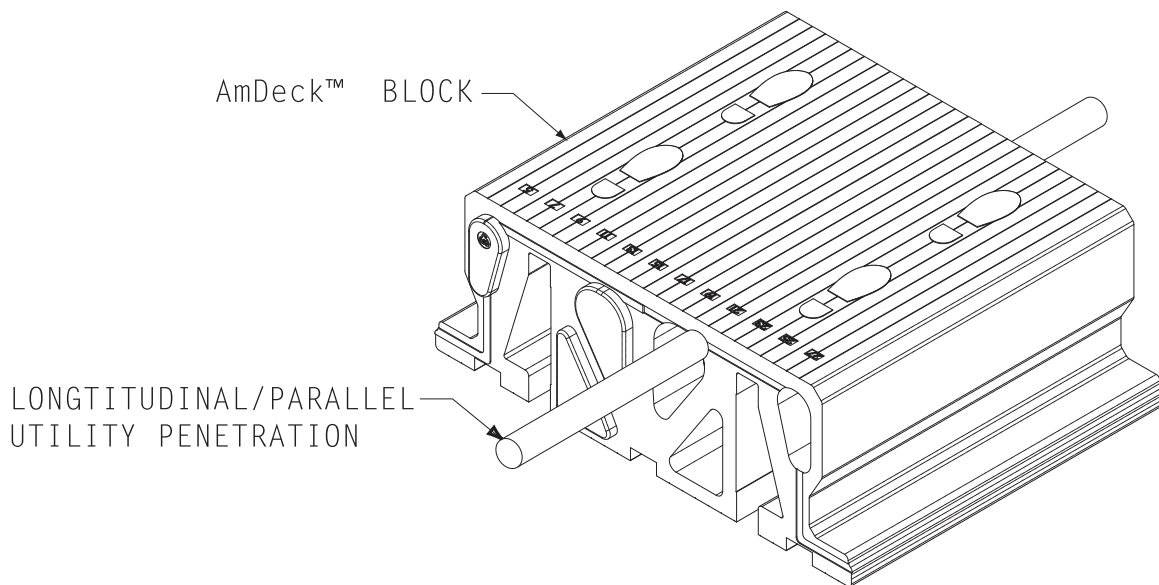

Figure 6.1 – Longitudinal utility/service penetration through AmDeck™

Each AmDeck™ unit has 4 main openings, as shown in Figure 6.2 below. The top two openings can accommodate conduits/pipes with OD up to 3-1/2 inches (89 mm), in addition to a variety of other small conduits and piping. The bottom two openings can house conduits/pipes up to 3 inches OD (76 mm). Two additional



side openings, one on each side can accommodate conduits/pipes with OD up to 2.25 inches (57mm).

Water supply lines, drainage pipes, electrical conduits and cable conduits can all be easily accommodated within the openings provided by the AmDeck™ system.

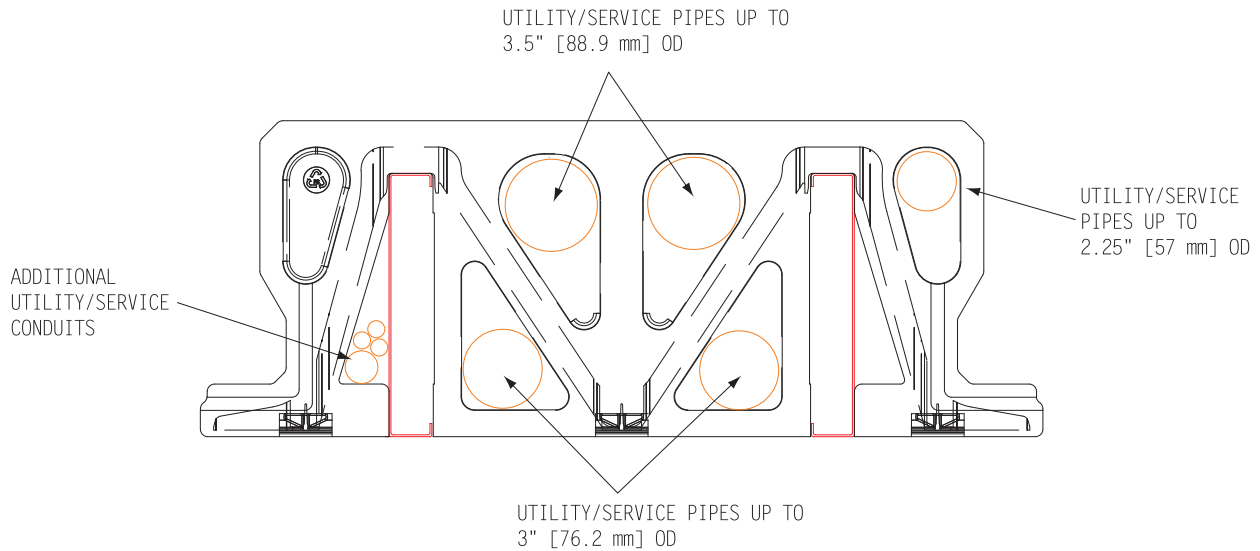

Figure 6.2 – Openings in AmDeck™ for ducts, cables, conduits and pipes

Utility and service installations that need to run longitudinally, and can fit within these dimensions, should utilize the openings provided by the AmDeck™ blocks, which have been designed for this very purpose. Amvic strongly recommends that such installation be carried out AFTER the concrete has been poured.

Pipes and conduits that need to be secured in place, e.g. fire sprinkler system, should be placed in the bottom opening and attached to the adjacent steel joists as illustrated in Figure 6.3 below.





Figure 6.3 – Fire sprinkler system attached to steel joist

Service and utility installations up to 4 inches OD (100 mm) can be accommodated by cutting away the EPS around the bottom openings, creating the required space. The conduit or pipe can then be secured to the steel joist as illustrated in Figure 6.4 below.

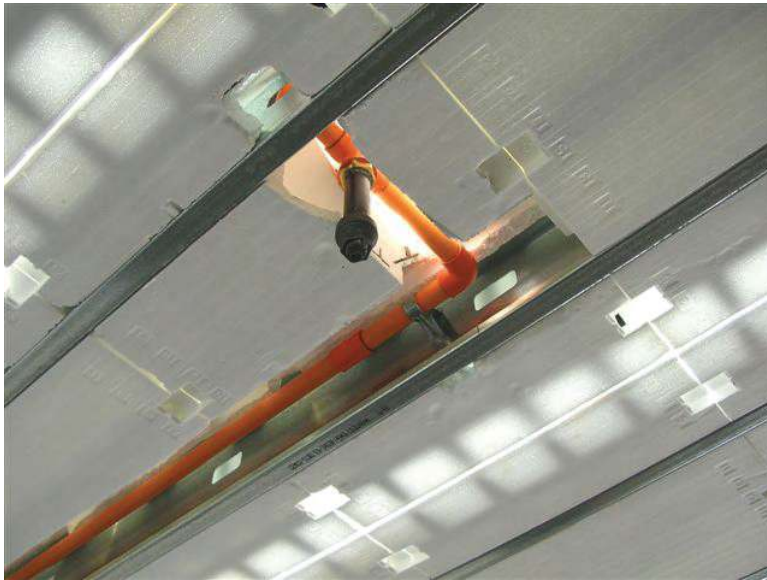

Figure 6.4 – Large pipe attached to steel joist





Important Note

Some contractors may choose to perform these installations *BEFORE* the concrete pour. In doing so, the utility or service trade crew may need to cut away some EPS in order to properly install the fittings. However, cutting EPS before pouring concrete weakens the structural integrity of the AmDeck™ blocks and may lead to EPS fracturing during the concrete pour. In such a case, the contractor should brace underneath the blocks that were compromised. This can be done by using an extra strip of shoring under those blocks that were cut.

6.4 – Transverse Utility and Service Installations

Figure 6.5 illustrates the orientation of utility and services that are installed transversely, that is, they are installed perpendicular to the steel joists.

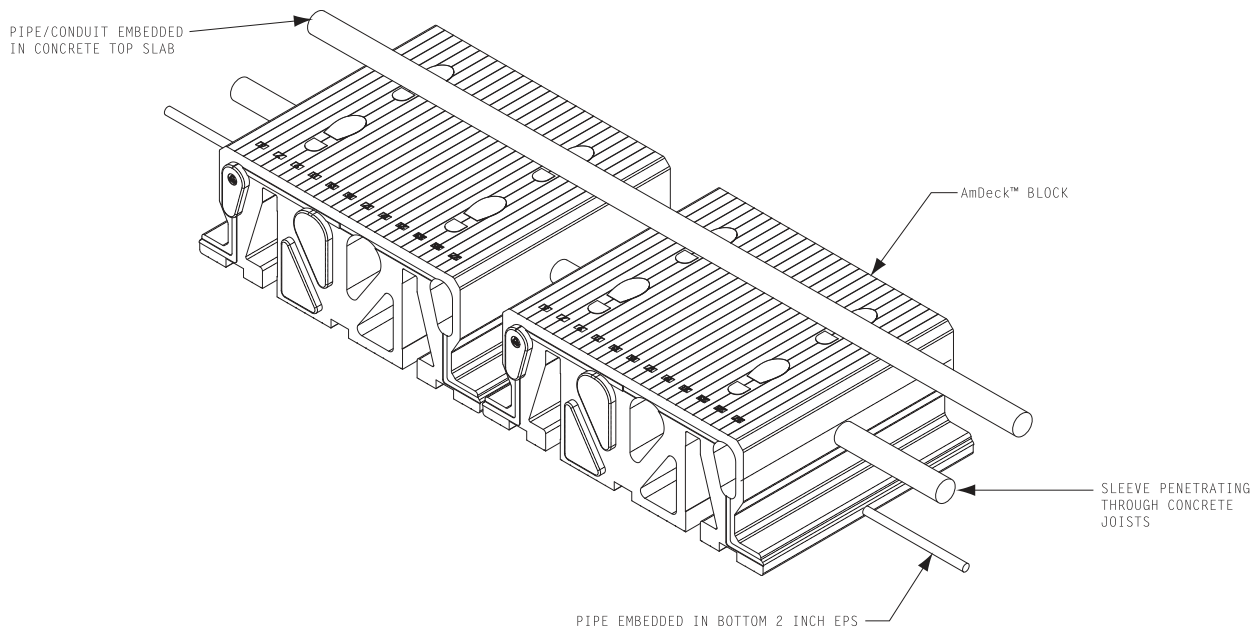

Figure 6.5 – Transverse utility/service penetration through AmDeck™



6.4.1 - Utility and Service Conduits/Pipes Embedded in the EPS

The concrete joists formed by the AmDeck™ blocks have 2 inches (51 mm) of EPS insulation layer underneath. Conduits and pipes with an OD within this dimension should be embedded in this 2 inch (51 mm) EPS layer, AFTER the concrete has been poured. To create a channel for the pipes/conduits, the EPS can be easily cut using a hot knife or a chainsaw with a depth-stop. Cutting through the steel joists can be performed using a drill with the appropriate steel boring bits and/or steel hole punch tools. The conduits/pipes are snugly fitted within the EPS and secured in place by applying foam adhesive at regular intervals. The pipes/conduits may also be attached to the steel joists using brackets and screws. With preplanning penetrations, openings through the steel joists can be made prior to the installation of the AmDeck™ forms. Mark the bottom of the joists to indicate the location of the penetration.

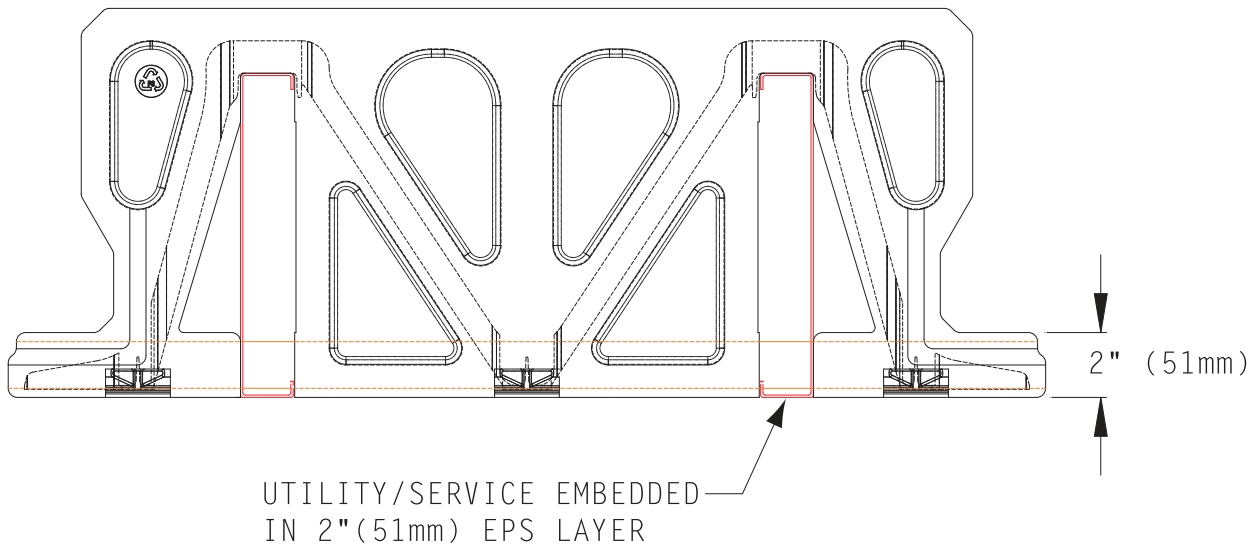

Figure 6.6 – Cross-section of utility/service pipe embedded in EPS

6.4.2 - Utility and Service Conduits/Pipes Penetrating Concrete Joists

Pipes, conduits and sleeves with an OD larger than 2 inches (51 mm) can penetrate through the concrete joists. The design engineer MUST review and approve the size and location of such a penetration in order to confirm that the structural integrity of the floor/roof is not compromised. For this type of installation, the pipes/conduits/sleeves shall be installed in place BEFORE the concrete pour.





Code Requirement

ACI 318-02 article 6.3.2 states “Conduits and pipes of aluminum shall not be embedded in structural concrete unless effectively coated or covered to prevent aluminum-concrete reaction of electrolytic action between aluminum and steel”



Important Note

Amvic does not recommend penetrations greater than 3-1/2 inches OD (89 mm) through the concrete joists. Therefore, conduits, pipes or sleeves with a larger OD should be accommodated using a drop ceiling, or embedded in an additional layer of lightweight concrete over the structural top slab.

For commercial structures with floors that require a very intense network of conduits/piping/cables, such as sound and film studios, the architect/engineer should consider other options including, but not limited to, the following:

- 1 – Use cable trays attached to the concrete joists to carry the necessary conduits/pipes/cables. The cable trays would typically be hidden within a drop ceiling.

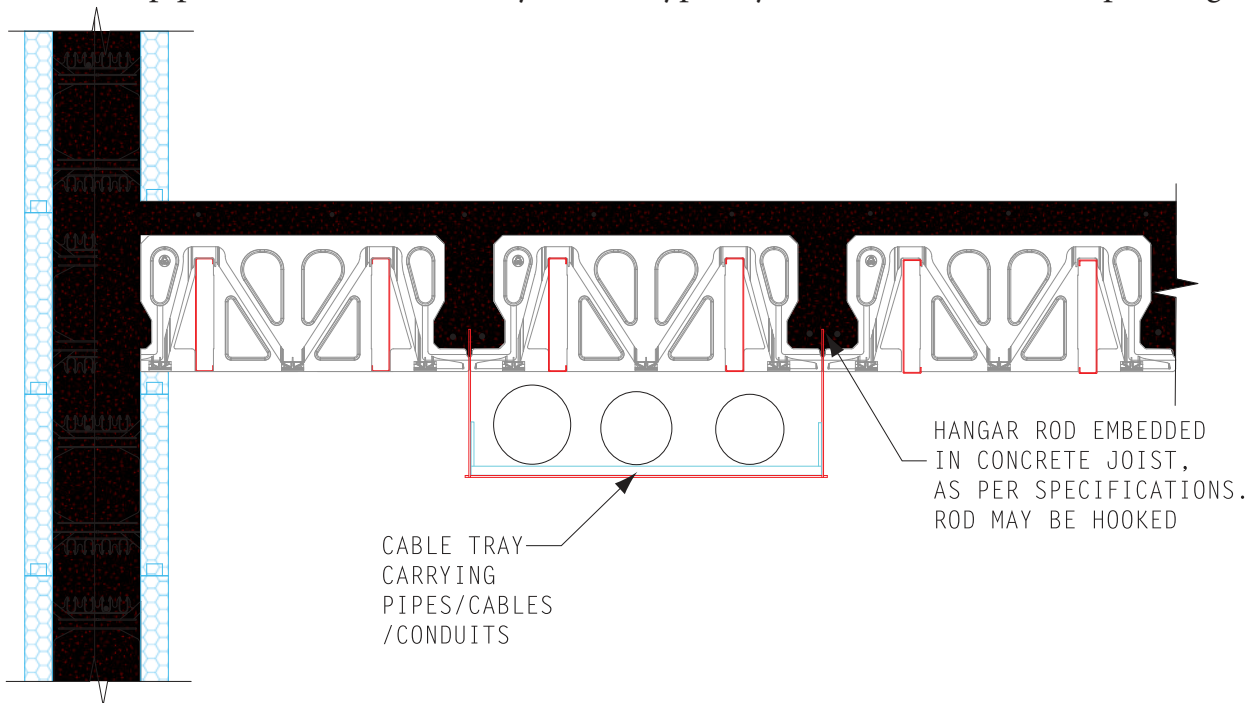

Figure 6.7 – Cable tray carrying conduits/pipes/cables, attached to the bottom of AmDeck™ joists



- 2 – Using raised access floor systems within which the conduits/pipes/cables are stored.

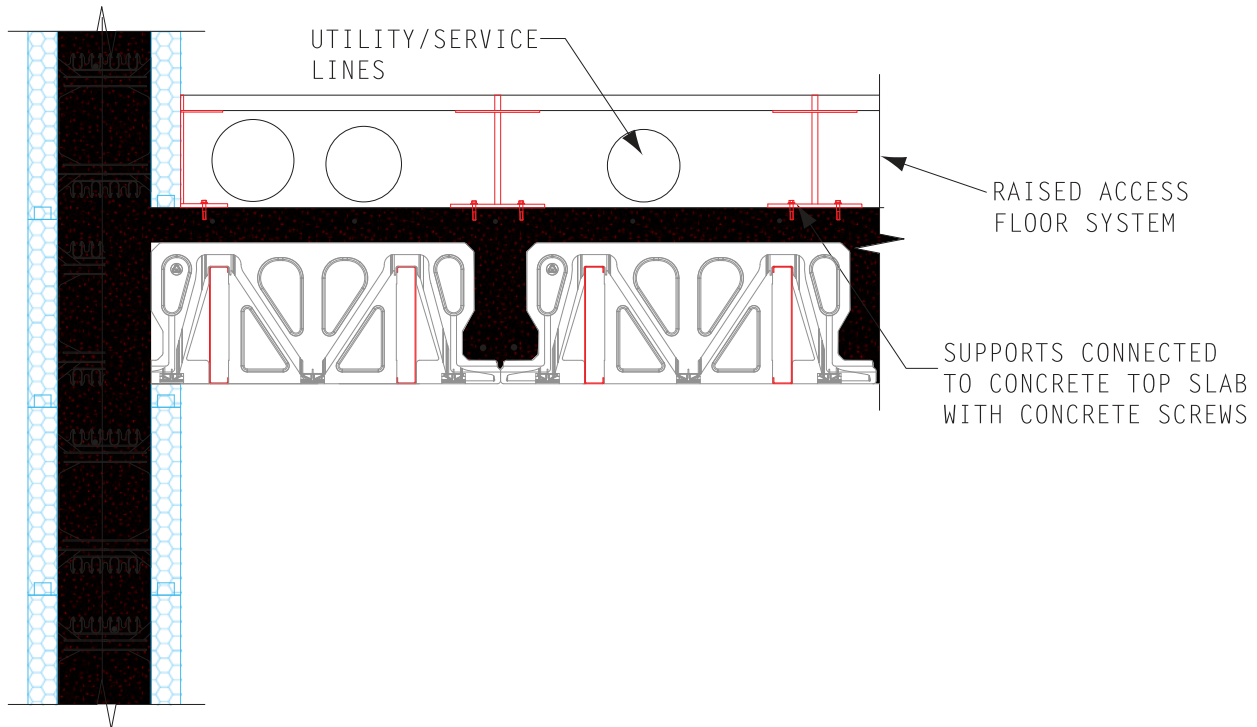

Figure 6.8 – Raised access floor system on top of AmDeck™

6.5 – Utility and service conduits/pipes embedded in Top Slab

Pipes and conduits with a 1 inch OD (25 mm) can be embedded in the concrete top slab. The design engineer shall review and approve the size and layout of the piping/tubing grid in order to confirm that the structural integrity of the floor system is not compromised. The most common type of utility that can be installed in the top slab is a radiant floor heating system which is covered in section 6.11.



6.6 – Vertical Utility and Service Penetrations and Openings

Figure 6.9 below illustrates the orientation of vertical utility and services penetrations through an AmDeck™ system.

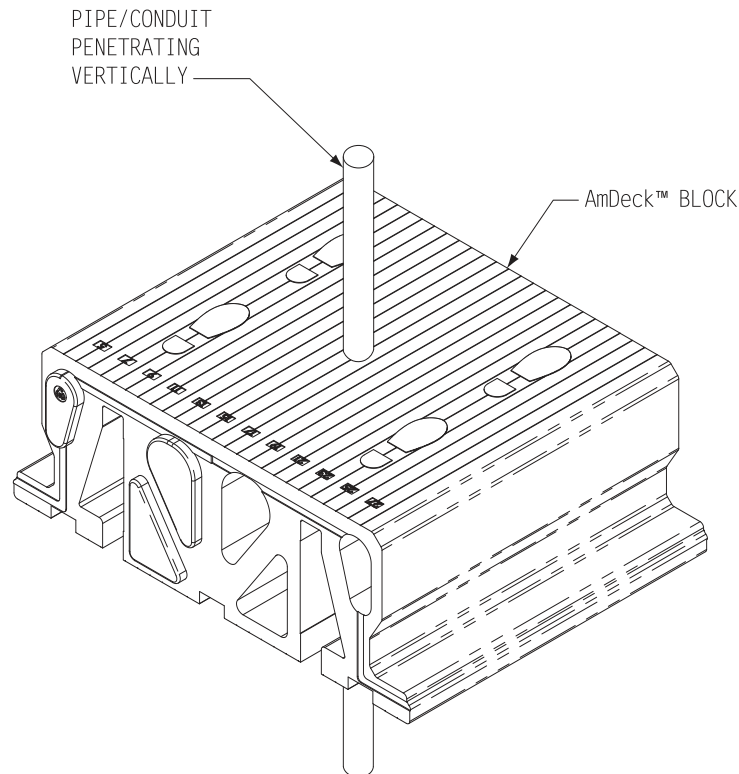

Figure 6.9 – Vertical utility/service penetration, 6 inches (152 mm) to 12 inches (305 mm), through AmDeck™

6.6.1 - Small Sized Vertical Penetrations

Conduits, pipes, sleeves as well as square and rectangular ducts with an OD or maximum dimension up to 6 inches (152 mm) may penetrate the AmDeck™ floor/roof deck as long as they are located between the steel joists, i.e. they penetrate through the top slab only, as illustrated in Figure 6.10 below.



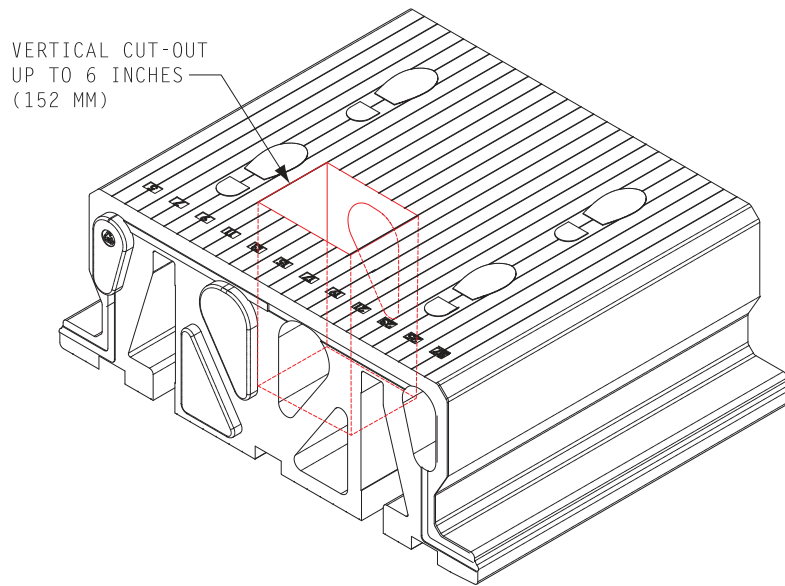

Figure 6.10 – Small sized vertical penetration through AmDeck™, located between steel joists

6.6.2 - Medium Sized Vertical Penetrations

Service and utility installations which require larger penetrations with an OD or maximum dimension larger than 6 inches (152 mm) and up to 12 inches (305 mm) may be created in an AmDeck™ floor/roof, provided that reinforcement is placed around the opening as illustrated in Figure 6.11 below.

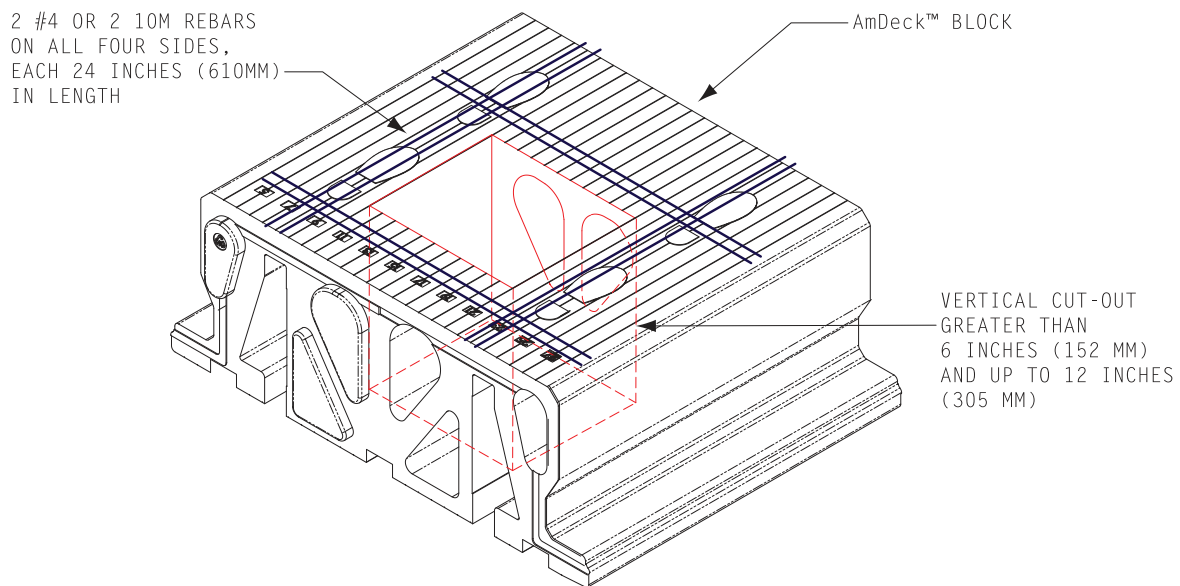

Figure 6.11 – Vertical utility/service penetration, greater than 6 inches, through AmDeck™





Important Note

If an AmDeck™ floor/roof is required by the local building code to have a certain fire-resistance rating (e.g. 1 hour), then all vertical pipes, conduits, ducts and cables which vertically penetrate the system **MUST** be properly firestopped with an approved or certified material. The firestop material would typically seal the opening between the penetrating pipe/conduit/duct and the concrete top slab as illustrated in Figure 6.11 below.

The firestop is specifically designed to restore the fire-resistance rating of the floor/roof assembly for which it was designed. Failure to properly firestop such penetrations would void the fire-resistance rating of the floor/roof assembly.

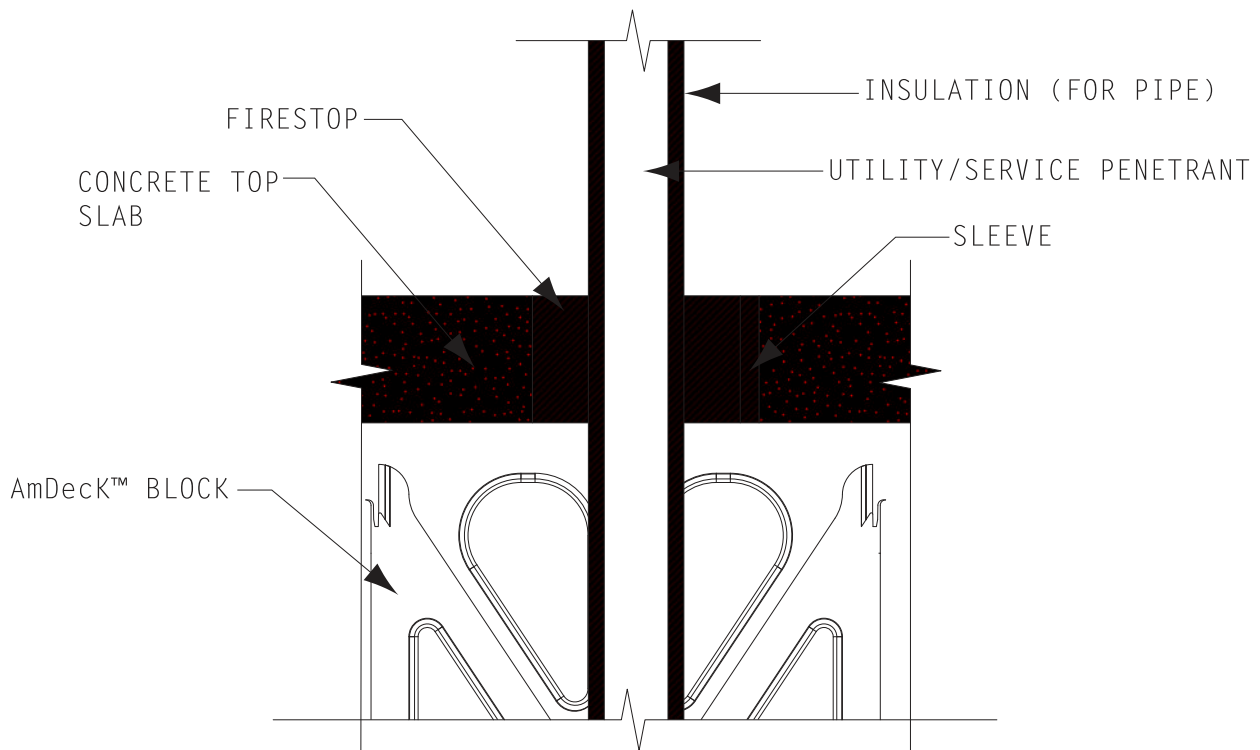

Figure 6.12 – Firestop for Vertical Penetration of Utility/Services through AmDeck™

6.6.3 - Creating Vertical Penetrations in AmDeck™

All penetration areas for utilities and services must be clearly marked on the foam for the required cut-outs/block-outs. The following steps are generally recommended:

1. Use a reciprocating saw or hole-bit and drill to cut the required opening.
2. Insert the utility or service line. A sleeve may be installed if required.



3. Seal around the external perimeter of the sleeve or utility/service line with a bead of low expansion foam to prevent leakage. For floors/roofs required to have fire-resistance rating, ensure to seal opening with a firestop as mentioned above.
4. Cap the ends of the penetrating pipe/conduit/duct to prevent the entry of concrete during the pour.

6.7 – Large Openings in the AmDeck™ System

Large sized openings with minimum dimensions larger than 12 inches (305 mm) and up to several feet (e.g. for a stairwell) can also be accommodated in an AmDeck™ floor or roof structure. For this situation, the design engineer should design perimeter beams supported on columns to create such openings. The perimeter beam and columns can be made of structural steel or reinforced concrete elements, depending on the designer's preference and architectural constraints of the project at hand. Figures 6.13 and 6.14 below, illustrate a typical large opening created for a stairwell using structural steel perimeter beams and columns.



Figure 6.13 – Large sized opening in AmDeck™ supported by steel perimeter beam and column.





Figure 6.14 – Large sized opening in AmDeck™ supported by steel perimeter beam and column.



6.8 – Large sized Duct System Installation

Utilities and services which require large sized ducts like an HVAC system, are more suitably accommodated using a drop ceiling (a.k.a. suspended ceiling). Minimum dimensions for such service installations are mostly over 5 inches (127 mm). The use of a drop ceiling provides great flexibility in installing such services, whether they run longitudinally or transversely to the AmDeck™ joists. The drop ceiling is installed by either attaching it to the concrete joists, or to the steel joists as described below.

6.8.1 - Drop Ceiling Attached to Concrete Joists

Attaching the drop ceiling to the concrete joists is a straightforward procedure. The attachment points can be made either before or after the concrete pour.

6.8.1.1 - Attachments Before the Concrete Pour

In order to provide for attachments before the concrete pour, steel hangar rods of specified length are inserted in place where the concrete joists will be formed, as depicted in Figure 6.15 below. After the concrete has been poured, these hangar rods serve as structural connectors to the drop ceiling framing system and can be cut to the required length for elevation adjustments. This method is by far the easiest and most cost effective to use.



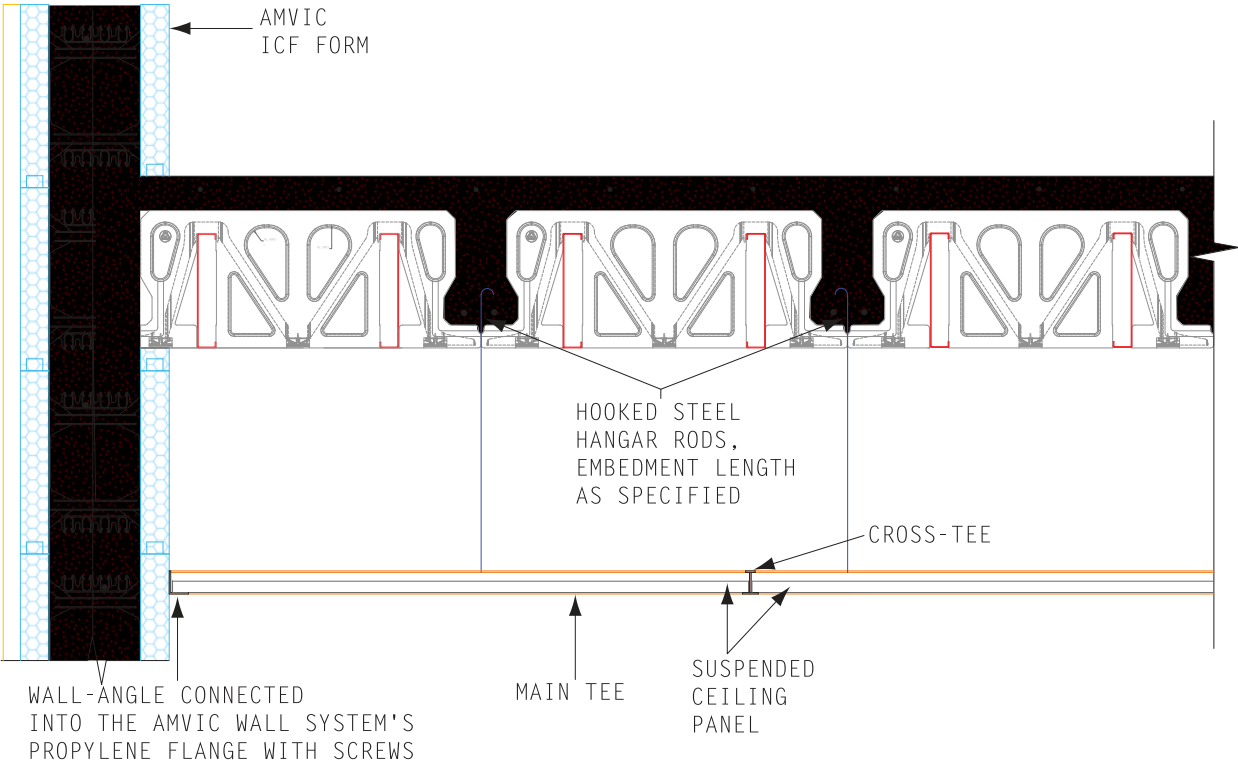

Figure 6.15 – Attachment of Suspended Ceiling Before Concrete Pour



6.8.1.2 - Attachments After the Concrete Pour

Attachment points can also be made after the concrete pour by drilling into the concrete joists, using an appropriate concrete anchor from HILTI, (or equivalent) as illustrated in Figure 6.16 below. Care should be taken when drilling the joists, to prevent cutting through the bottom reinforcing steel.

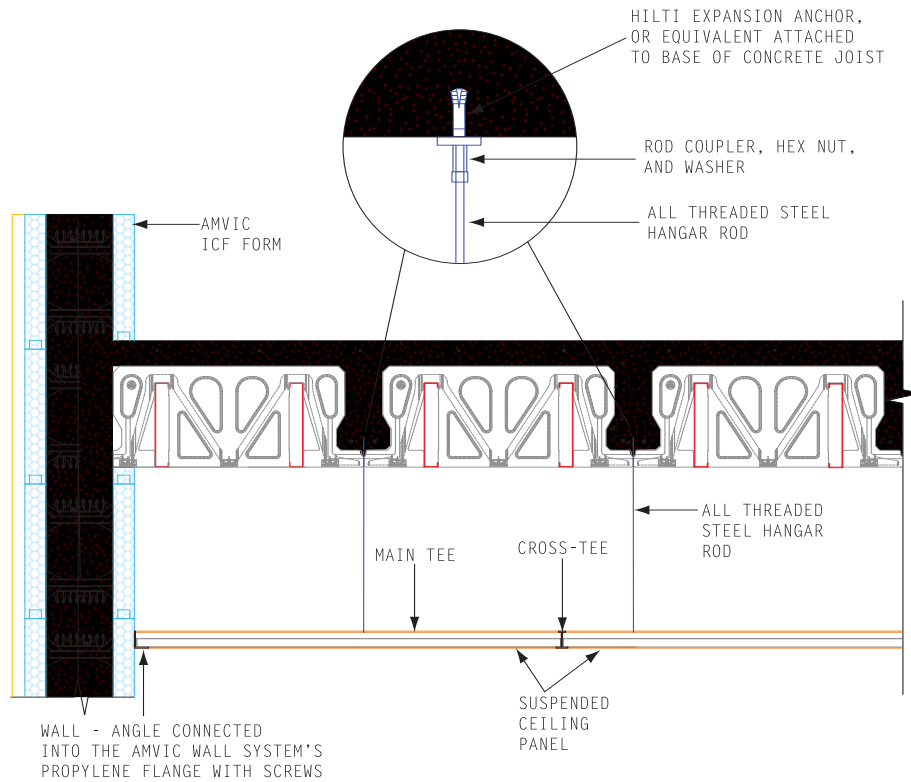

Figure 6.16 – Attachment of Suspended Ceiling After the Concrete Pour



6.8.2 - Drop Ceiling Attached to Steel Joists

Drop ceilings can also be attached to the steel joists as illustrated in figure below. The attachments are most efficiently done after the concrete has been poured.

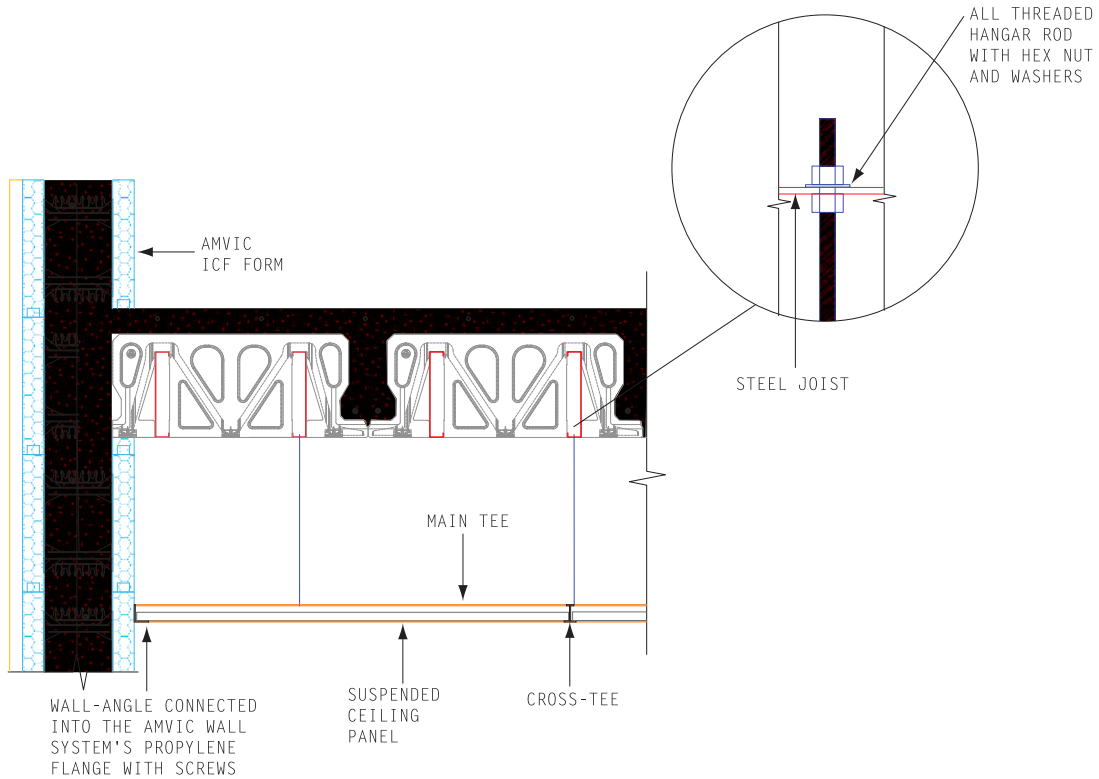

Figure 6.17 – Attachment of Suspended Ceiling to Steel Joists After the Concrete Pour



6.9 – Special Installations on AmDeck™: Attaching the Floor Boot

The ducts for a forced air system are connected to the floor vent by the floor boot, as shown in Figure 6.18. The floor boot should be installed as follows:

1. Place the wooden inserts on the AmDeck EPS,
2. Place foam in between the wooden inserts (as per HVAC design sizing, e.g. 4 inches x 10 inches, 102 mm x 254 mm).
3. Pour the concrete.
4. Let the concrete set.
5. Remove the foam.
6. Attach the floor boot onto the remaining wooden inserts.

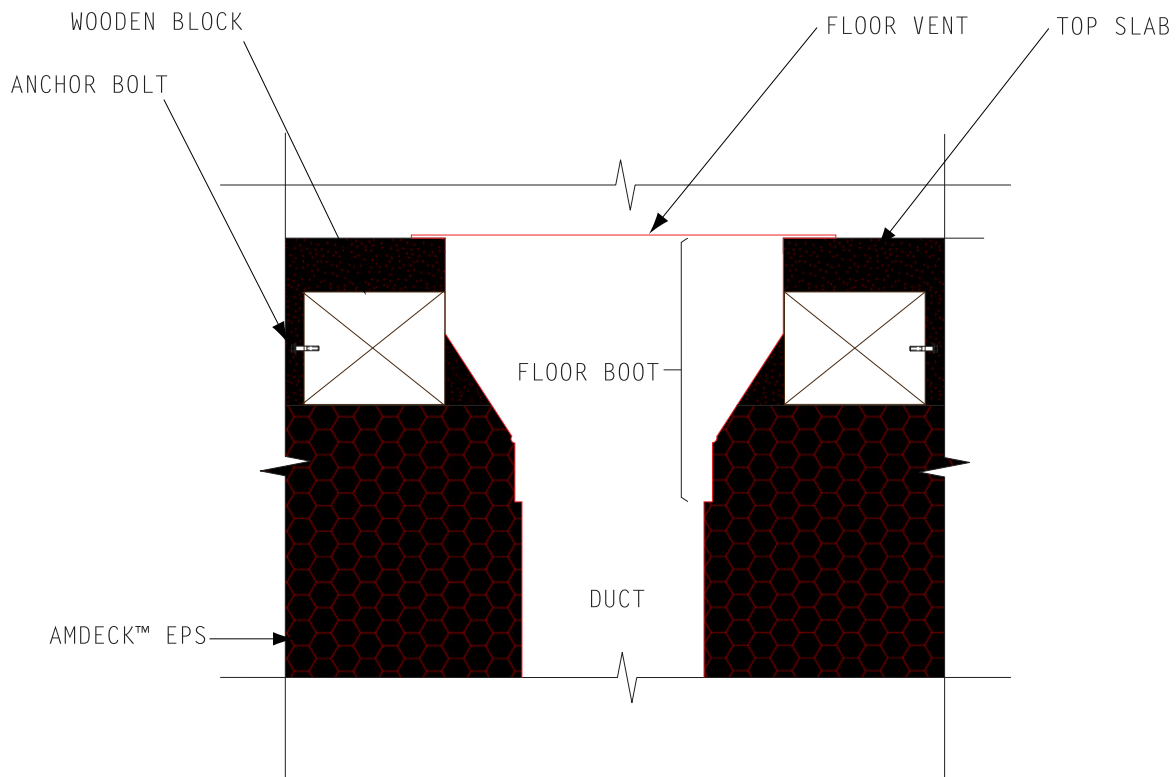

Figure 6.18 – Floor Boot Installation



6.10 – AmDeck™ and Radiant Floor Heating Installation

6.10.1 - Overview

A typical radiant floor heating system consists of several components including but not limited to:

1. Heating source
2. Pressure and temperature gauges
3. Pressure release valves
4. PEX Tubing, fittings, adapters and couplers
5. Manifolds

For the purpose of AmDeck™ installation, the tubing is the most important part of a radiant floor heating system since it will be embedded in the AmDeck™ top slab. Radiant floor heating tubes will generally range in size between 3/8 inch - 1 inch OD (9.5 mm to 25.4 mm) depending on design and heat output requirements for a given space.

Most radiant floor tubes are made of cross linked polyethylene (a.k.a. PEX) which is widely considered as the best and most durable plastic for radiant floor heating systems.

The tubes are laid out in loops or circuits of varying shapes and lengths with a typical spacing of 6 inches (152 mm), 8 inches (203 mm), 12 inches (254 mm) or 16 inches (406 mm) depending on the size of the tubing used. Each circuit is connected to a manifold which is typically located close to the heating source.

6.10.2 - Radiant Floor Placement

Amvic recommends that radiant floor heating tubing be installed directly on top of the AmDeck™ EPS rather than attached to the longitudinal or transverse reinforcing steel in the top slab. Installing the tubing as such has the following advantages:

1. Radiant heated slabs radiate outward rather than downward. When installed directly on the EPS the tubes have more concrete thickness on top which means more thermal mass to heat, making the system much more efficient.
2. More concrete thickness to heat means the top slab will be heated more evenly and there is less chance of experiencing localized warm spots.
3. Installing the radiant floor heating tubes attached to the top slab mesh is more prone to construction errors. Many installers tend to run the tubing parallel to and directly in contact with reinforcing bars (side by side) for



several feet of length. This significantly reduces the bond between the reinforcing steel bars and the concrete, which compromises the structural integrity of the floor system.

4. When installing floor finishing systems such as hardwood, nails or screws may need to be driven into the top concrete slab. When the radiant floor tubing is installed on top of the AmDeck™ EPS, there is more concrete cover for protection and the risk of puncturing or damaging the tubes is greatly reduced.

6.10.3 - Radiant Floor Installation Steps

The recommended installation procedure for radiant floor heating tubes with an AmDeck™ floor is as follows:

1. Lay out the PEX tubes as per the design drawings directly on top of the AmDeck™ EPS. This should be done before any of the longitudinal or transverse reinforcing steel for the top slab is installed.
2. Use the PEX tube staples to tie the tubes to the EPS foam. Staple the tubes every 6 feet (1.82 meters) initially. This will keep the tubes roughly in place while working on the rest of the layout and pattern. Once the tubing has been completely installed and the necessary adjustments have been made, go back and staple the tubing at every 2 feet (0.61 meters). This will ensure that no significant movement will occur during the concrete pour.
3. Connect the tubing to the floor manifold using the appropriate fittings or couplers.
4. Place the supporting chairs for the reinforcing steel bars on top of the AmDeck™, spacing them in between the radiant floor heating tubing.
5. Install the longitudinal and transverse reinforcing steel as per the engineering requirements and specifications.
6. Prior to the concrete pour, follow the manufacturer's (radiant floor heating system) procedure for pressurizing and leakage testing of the tubes. If required, perform the necessary repairs.





Construction Tip

- 1. If concrete needs to be wheeled across the floor, lay down some plywood planks to spread out the weight and protect the radiant floor tubing.*
- 2. Do not allow debris to enter tubing. Keep ends of tubing taped during construction.*
- 3. Wrap around the tubing using cloth or an old rag where it enters the manifold box. This prevents any concrete from flowing into the box and the manifold.*



Part 7 – The Installation Process

7.1 – Overview

A typical AmDeck™ project requires planning for both construction site safety as well as installation activities. This part of the manual covers site safety/emergency briefly, but mainly focuses on describing the detailed steps of installing an AmDeck™ floor or roof system in the most efficient manner. Towards the end of this section, the contractor/installer should be ready to pour the concrete.

7.2 – Safety and Emergency Planning

7.2.1 - Construction Site Safety

Working on any construction site may present a variety of hazards to both the construction personnel as well as the public. Amvic strongly recommends that all safety concerns be properly addressed before construction work is started. Some of the more important construction site safety issues that need proper attention include, but are not limited to the following:

- 1 - Site excavation
- 2 - Fire prevention and safety
- 3 - Protection of public during construction activities
- 4 - Protection of adjacent property
- 5 - Direction of vehicular traffic
- 6 - Waste material management



Important Note

Amvic recommends that the contractor/installer reviews the following documents:

- 1 - *The National Building Code of Canada (NBC 2005) part 8 “Safety Measures at Construction and Demolition Sites” - in Canada*
- 2 - *The International Building Code (IBC 2006) chapter 33 “Safeguards During Construction” – in the U.S.A*





Code Compliance

Construction site safety must be in compliance with the following codes/standards:

- 1 - OHSA (Occupational Health and Safety Act) including the applicable parts and subsections pertaining to Construction Projects – in Canada*
- 2 - OSHA (Occupational Safety and Health Administration) 29 CFR Part 1926 “ Safety and Health Regulations for Construction” – in the U.S.A*

7.2.2 - Scaffolds, Platforms and Guardrails

Installation of an AmDeck™ floor or roof system will require the construction crew to work at elevated heights above ground level, or above a lower level. In most cases, this will require the use of scaffolds with suitable working platforms/planks to move and maneuver the AmDeck™ blocks from ground level, to where they will be installed. Scaffolds and working platforms used on the construction site shall be in compliance with the following codes/standards:

- a - OHSA (Occupational Health and Safety Act) Part II sections 125 to 136 - Canada
- b - OSHA (Occupational Safety and Health Administration) 29 CFR Part 1926 subpart L 450 to 454 - U.S.A

Once the AmDeck™ steel joists and blocks have been installed, the construction crew will need to use it as a working platform in order to install reinforcing steel and other utility and service pipes or conduits. Elevated working platforms will require 42 inch (1.05 m) guardrails to protect the crew from falling off the edge of the floor or roof system. Guardrails shall be designed to be in compliance with the following codes/standards:

- a - OHSA (Occupational Health and Safety Act) Part II section 26 - Canada
- b - OSHA (Occupational Safety and Health Administration) 29 CFR part 1926 section 502 - U.S.A



7.2.3 - Personal Protective Equipment

All local codes/standards in North America require the construction crew and any other personnel on the construction site to wear the appropriate personal protective equipment AT ALL TIMES. This includes but is not limited to the following:

- 1 - Protective headwear i.e. appropriate hard hats.
- 2 - Appropriate footwear to protect toes against impact and feet against penetrations by sharp objects.
- 3 - Protective face and eyewear e.g. goggles when necessary.
- 4 - Appropriate clothing to protect skin against irritation or burns caused by harmful substances.

7.3 – Construction Planning

7.3.1 - Ordering AmDeck™ Joists

Order the AmDeck™ steel joists to the required lengths for your project. Keep in mind that the joists need to have a minimum bearing length of 4 inches (100 mm) on both ends. For example, if the clear distance between the two bearing structures (e.g. a wall or a beam) is 20 feet (6.1 meters) the joists should be ordered to a length of:

$$20 \text{ feet} + (2 \times 4 \text{ inches}) = 20 \text{ feet} - 8 \text{ inches} (6.3 \text{ meters})$$

7.3.2 - Storing AmDeck™

If AmDeck™ blocks will be stored on the jobsite for prolonged periods, ensure they are protected from sunlight, dust, moisture and extreme weather by storing them in a contained environment. The storage location should be a safe place that will not impede or present a hazard to the construction traffic.

7.3.3 - Planning for Shoring/Bracing

Shoring and bracing is an important part of constructing an AmDeck™ floor or roof system in terms of materials, labor, equipment and project economics. The contractor should accommodate these items into his construction schedule well ahead of time, by reviewing the construction details for shoring/bracing/formworks thoroughly. Please refer to Part 5, Section 5.1 for shoring requirements and Appendix A for shoring spans.



7.3.4 - Planning for Utility/Service Penetrations

The contractor/installer should plan for all services and utilities that will either penetrate or be embedded in the AmDeck™ floor or roof, by reviewing the construction plans carefully. This will greatly increase construction efficiency, which ultimately reduces the overall project cost.

7.3.5 - Planning Interior Finishing

Some interior finishing requires careful planning to accommodate the necessary structural attachments before the concrete pour. The contractor/installer shall review the construction plans and documents carefully in order to plan for such structural attachments. Please refer to Part 9 of this manual for more details on interior finishing.

7.4 – Installing the forms

7.4.1 - Construction Crew

A minimum construction crew made up of 4 people is typically required to move, handle and install the AmDeck™ steel joists and forms .

7.4.2 - Mobilization

To maximize construction efficiency, place materials as closely to where they will be installed as possible. This should be pre-planned to accommodate the construction site layout and size.

1 - Placing materials within the floor perimeter

Where possible, place the AmDeck™ blocks and steel joists (diagonally) within the wall perimeter. The blocks and joists can then be lifted to the specified elevations and installed in place. Please refer to figure 7.1 below.



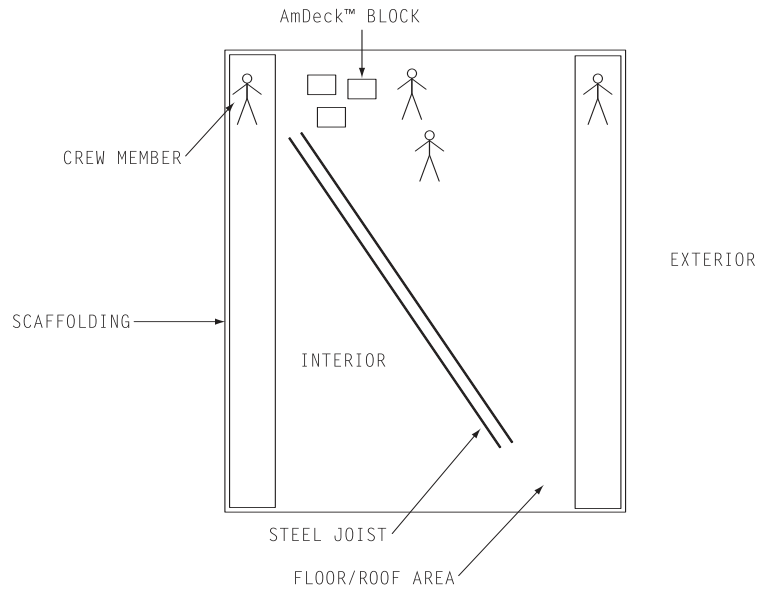

Figure 7.1 - Placing the AmDeck™ joists and blocks within the wall perimeter

2 - Placing materials outside of the wall perimeter

If materials must be placed outside the wall perimeter, the blocks and joists will have to be lifted into place using a crane or other suitable method. Please refer to figure 7.2 below.

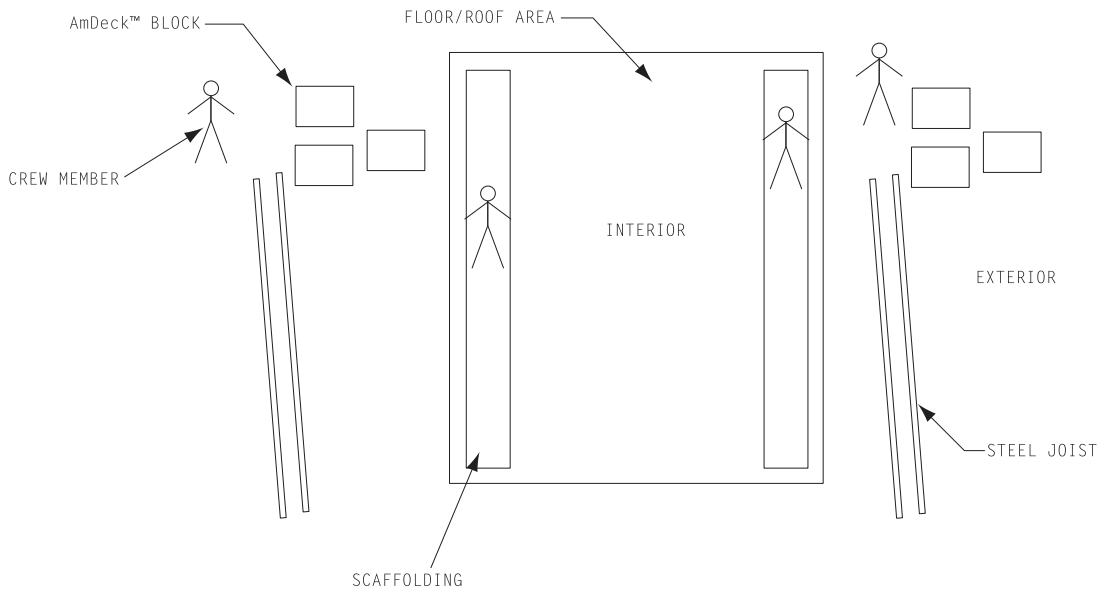

Figure 7.2 - Placing the AmDeck™ joists and blocks outside of wall perimeter



7.4.3 - Installing the first steel joist

7.4.3.1 - Establishing Location of First Steel Joist

The installation of the first steel joist depends on how the AmDeck™ forms will be placed, with respect to the adjoining wall or supporting structure.

There are two ways of installing the first joist. You may place the AmDeck™ form flush with the edge of an ICF wall. In this case, cut 2-1/4 inches (57.15 mm) from the bottom lip of the block and place the steel joist at a distance of 5-3/4 inches (146 mm) from its centerline to the edge of the EPS as illustrated in figure 7.3.

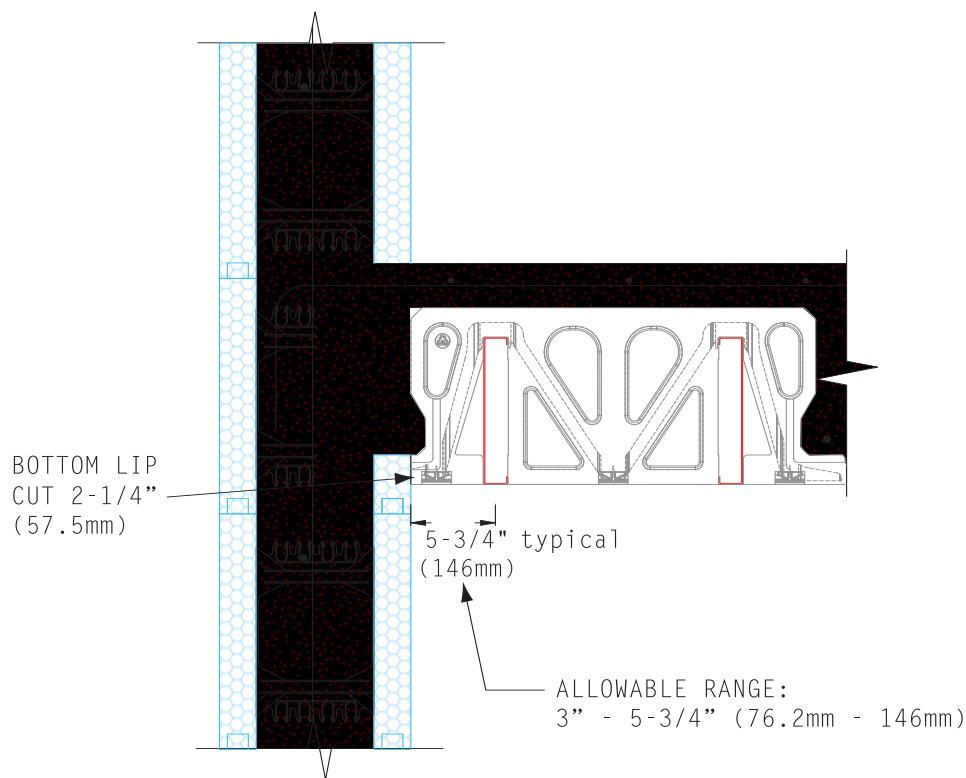

Figure 7.3 - AmDeck™ flush with an ICF wall

Alternatively, the AmDeck™ EPS can rest on top of the ICF EPS. As with the previous case, Amvic recommends cutting away 2-1/4 inches (57.15 mm) from the bottom lip of the block and installing the steel joist 3-1/4 inches (82.55 mm) from its centerline to the edge of the ICF wall EPS as illustrated in figure 7.4.



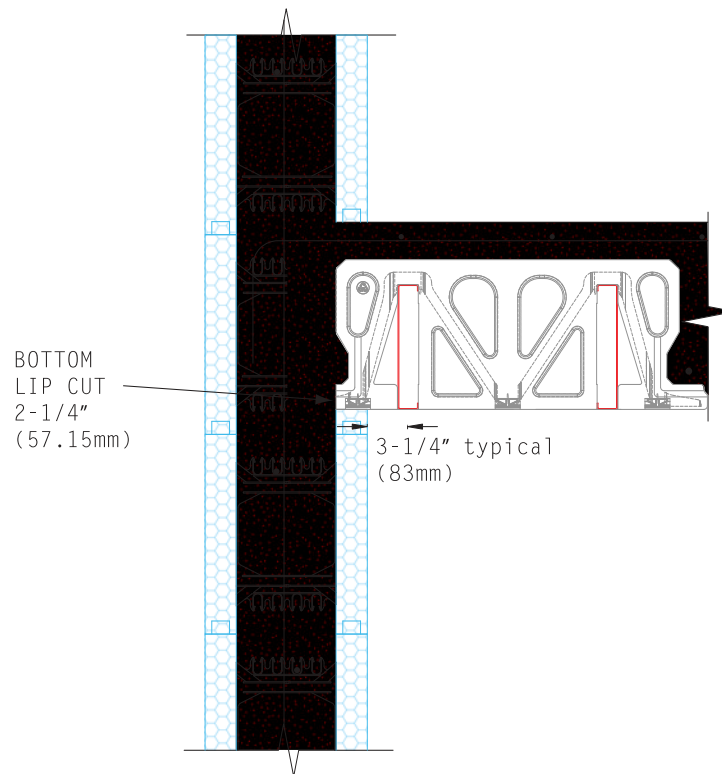

Figure 7.4 - AmDeck™ on top of wall EPS

Installing AmDeck™ with other structural systems may need some dimensional planning as illustrated above, in order to determine the location of the first steel joist. Once established, the exact location of the first steel joist from the wall should be marked with a chalk-line or pin. This will determine both the location and number of joists to be used on the deck.



7.4.3.2 - Installing the First Steel Joist

Place the first steel joist with a bearing length of at least 4 inches (101.6 mm) on each side onto the ICF walls or other supporting structural system with the open side facing inward.



Figure 7.5 – Steel joist bearing 4 inches on an ICF wall

7.4.4 - Installing the Second Steel Joist

Place the second steel joist at exactly 16 inches (406.4 mm) centerline to centerline from the first one with the open side facing the first joist, as illustrated in figure 7.6 below.





Figure 7.6 – Steel joists placed correctly with C-channels facing each other

Once a pair of joists has been installed place an AmDeck™ form at each end. This will ensure that the joists are secured in position.



Figure 7.7 - Installing the AmDeck™ Blocks at each end of steel joist pair



7.4.5 - Installing the Remaining Steel Joists

Next, install the remaining steel joists in the same manner as the first pair, by placing them 16 inches (406.4 mm) apart (centerline to centerline). Ensure that each pair have their open ends facing towards each other. For every pair of steel joists completed, install an AmDeck™ form at either end to secure the joists into position.

7.4.6 - Installing the remaining AmDeck™ Forms

Having completed the installation of the steel joists, the remaining AmDeck™ forms can now be installed. Work on one pair of joists at a time, stacking from one side to the other.



Figure 7.8 - Installing AmDeck™ blocks from one end to the other



Note

You should have at least one EPS block installed already at either end of the joists as per sections 7.4.4 and 7.4.5



7.4.7 - Installing the Last AmDeck™ Block

In most cases, the dimensions between walls or other structural elements are not exact multiples of an AmDeck™ block dimension. This is true for both the transverse and the longitudinal direction. This entails cutting the block to accommodate the site-specific dimensions.

7.4.7.1 - Transverse Cut

The last block in an AmDeck™ row may need to be cut transversely as shown in Figure 7.9.

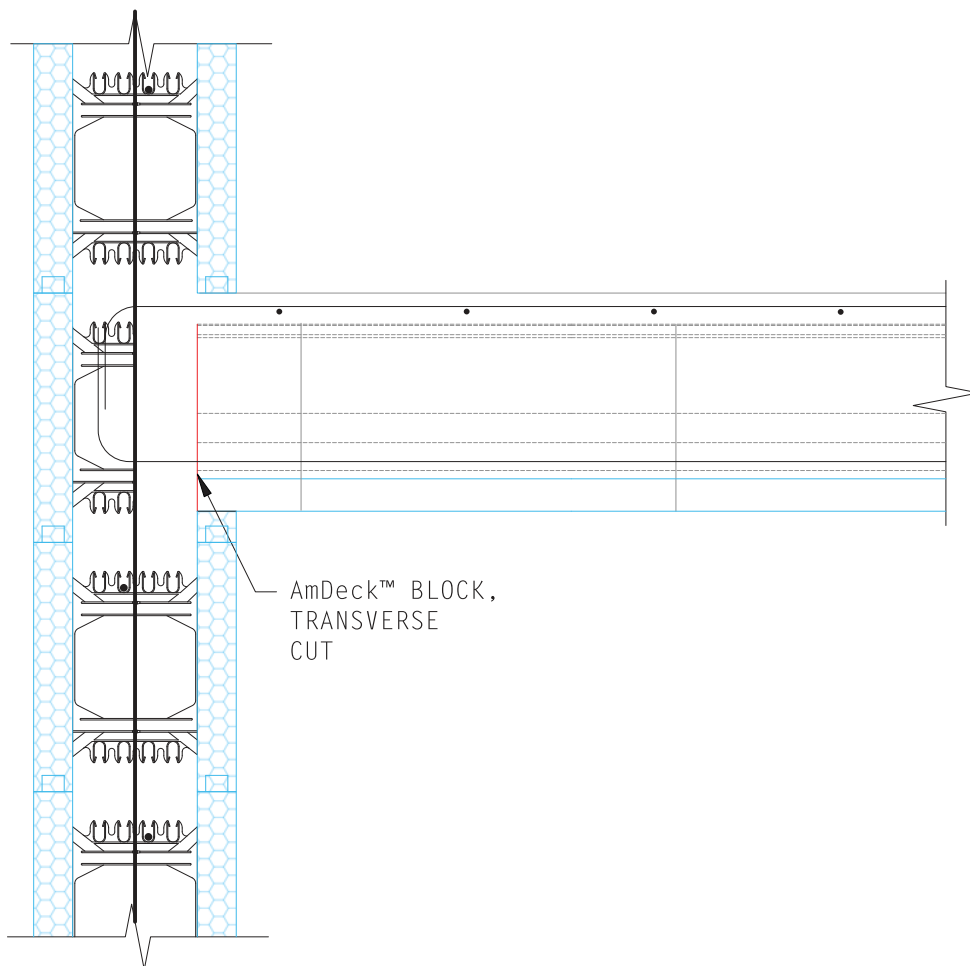

Figure 7.9 – AmDeck™ block cut transversally



Measure the required length for the last block to be inserted in the row. Use a chain saw to cut a fresh block to that same length as shown below.



Figure 7.10 - Cutting the final block in the row

The cut block is then fitted in place as illustrated in Figure 7.11 below.



Figure 7.11 – Placement of AmDeck™ block cut transversally





Figure 7.12 – A completed AmDeck™ row



7.4.7.2 - Longitudinal Cut

A complete row of AmDeck™ blocks may need to be cut longitudinally in order to accommodate the site-specific dimensions. Again, this can be done by measuring the required width of that last row and cutting the blocks using a chain saw. Depending on where your longitudinal cut is along the blocks, OSB sheets or the equivalent may be needed at the soffit, in order to support that row during the concrete pour. This is illustrated in Figures 7.13 and 7.14 below.

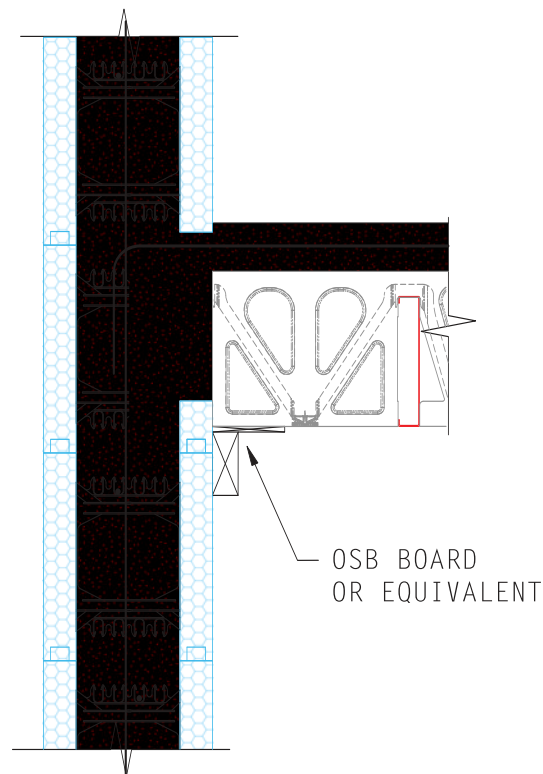

Figure 7.13 – Longitudinally cut AmDeck™ block, supported by OSB and Plywood





Figure 7.14 – Longititudinally cut AmDeck™ block, supported by OSB board



7.4.8 - Sealing Seams/Gaps and Providing End Covers

Various areas on the AmDeck™ block must be sealed prior to the concrete pour, and are discussed in this section.

7.4.8.1 - Sealing Seams and Gaps

Seal all seams and gaps between forms and all edges using low expansion foam adhesive to prevent the leakage of paste and water during and after the concrete pour, as shown in Figure 7.15 below.



Figure 7.15 – Sealing gaps between AmDeck™ forms

7.4.8.2 - End-Covers

The ends of the first and last AmDeck™ blocks for every row must be covered, to prevent them from being filled with concrete during the pour. For this purpose, Amvic provides end covers made from EPS, as shown in Figure 7.16. The end covers should be attached using low expansion foam adhesive. A bead should be run around the contact points with the joist in order to provide additional strength.





Figure 7.16 - AmDeck™ End Covers

As an alternative to the end covers (if they will not be used, or the contractor/installer runs out of them) scrap foam cuts or other suitable materials can be used to cover the AmDeck™ block openings.

A piece of wood block cut to shape and dimension can also be inserted in the steel joists to prevent them from being filled with concrete as illustrated in figure 7.17.



Figure 7.17 - Inserting a wood block in the steel joists





Moisture Control

The amount of water absorbed by the EPS form blocks is less than 3.0% of the volume of the block. However, water may enter into the cavities of the AmDeck blocks during the construction phase from the two open ends of the form block. It is the responsibility of the installer to make sure that during the construction phase the blocks are emptied of rainwater and the forms are kept dried. If the water gets into these cavities anytime during construction, the floor system must be completely dried and moisture free prior to the attachment of finishing building materials on either side of the system.

7.4.9 - Installing the Shoring

Install shoring as per engineering drawings prepared by the formwork engineer/contractor (please refer to Part 5, Section 5.1 of this manual).



Construction Tip

Erecting the shoring after the joists and EPS blocks have been installed is recommended for spans that are 20ft (6.0 m) or less. This will give the construction crew more space to work with and maneuver the steel joists and the EPS blocks, especially if they will be placed within the wall perimeter immediately before installation.

Spans that are more than 20ft (6.0 m) should have the shoring erected in place PRIOR to installing the steel joists and EPS blocks.

7.4.10 - Installing Bottom Steel Reinforcement

The bottom steel reinforcement must be installed according to engineering specifications and drawings. A minimum clear cover of 3/4 inch (19 mm) must be provided. Please refer to Part 5.3 of this manual for more details regarding bottom steel reinforcement.

7.4.11 - Installing Utility and Service Penetrations

Install sleeves for utilities and services that will penetrate the concrete joists or the top slab. It is essential that such penetrations be located accurately due to their effect on the structural integrity of the whole floor system. As such, the contractor/installer shall follow the structural drawings as close as possible to ensure that the sleeves are



of the correct sizes and located properly. Please refer to Part 6 of this manual for more details on utility and service penetrations.

7.4.12 - Installing Radiant Floor Heating (Optional)

Install the radiant floor heating tubing on top of the AmDeck™ EPS. Improper installation of radiant floor heat tubing may compromise the structural integrity of the floor system. Please refer to Part 6, Section 6.11 of this manual for proper installation instructions.

7.4.13 - Installing Utility and Service Penetrations Embedded in Top Slab

Install utility or service conduits/pipes/tubing embedded in the AmDeck™ top slab as per engineering drawings and specifications. Like radiant floor heating, utility and service penetrations embedded in top slab, if improperly installed, can adversely affect the structural integrity of the slab by interference with the reinforcing steel. Refer to Sections 5.3, 6.4.2 and 6.5 for proper installation details and information on the general layout of the steel reinforcement in the AmDeck™ system.



Figure 7.18 – Pipe placed in the AmDeck™ top slab region.



7.4.14 - Installing Transverse and Longitudinal Reinforcing Steel

Install the transverse and longitudinal reinforcing steel as per engineering drawings and specifications. The transverse steel should be located in the middle of the top slab. The longitudinal steel may be installed on top or beneath the transverse steel, depending on the clear cover requirements and other engineering concerns.



Figure 7.19 - Transverse and Longitudinal Steel

7.4.15 - Checking For Level

The entire structure must now be checked for level, using a laser level. Make any necessary adjustments. Take numerous points of reference to ensure that the proper level is achieved

7.4.16 - Forming the Perimeter

7.4.16.1 - Forming Perimeter with ICF Walls

If AmDeck™ is being used in conjunction with Amvic Insulated Concrete Forms (ICF) or another brand of ICF walls, cut one row of wall forms halfway between the webs using a reciprocating saw or shears, as shown in Figure 7.20.





Figure 7.20 - Amvic ICF cut halfway



Figure 7.21 - Another view of Amvic ICF cut halfway



Tie the reinforcing steel from the AmDeck™ top slab, onto the horizontal reinforcement from the ICF wall, as illustrated in Figure 7.22 below.



Figure 7.22 - Tying the top slab reinforcement with the horizontal bars on ICF wall



Guardrails used for fall protection (please refer to section 7.2.2) should also be used to further brace the outside perimeter of the wall. This can be achieved by screwing the guardrail uprights to the polypropylene webs of the walls. Horizontal boards are then run across and either nailed or screwed to the uprights connecting them together, as shown in figure 7.23 below.



Figure 7.23 - Using guardrail uprights and horizontals to brace perimeter of wall



7.4.16.2 - Forming Perimeter with Concrete Beam

If AmDeck™ will be connected to a concrete beam, the concrete beam should be formed using traditional formworks and braced from the outside as illustrated in the Figures 7.24 and 7.25 below.



Figure 7.24 – Formwork for concrete beam construction



Figure 7.25 – Bracing the formwork for concrete beam



7.4.16.3 - Forming Perimeter with Steel Beam

If you are forming the perimeter with a steel beam, no formwork is required since the steel beam will contain the concrete. However it is necessary to seal the gaps created by the connection between the AmDeck™ steel joists and the perimeter steel beam, as illustrated in Figure 7.26 and 7.27 below.



Figure 7.26 – Connection between steel joists and steel beam



Figure 7.27 – Underside of connection between steel joists and steel beam



7.4.17 - Additional Shoring and Bracing

In some cases the AmDeck™ EPS is cut away to accommodate utility and service lines as discussed in Part 6 of this manual. While this is acceptable, Amvic recommends bracing areas where a significant portion of the EPS has been cut away, using OSB boards and/or localized shoring strips, as shown in figure 7.28 below.



Figure 7.28 – Extra bracing for AmDeck™



Part 8 – Concrete Placement

8.1 – Overview

This part of the manual covers the concrete pouring and consolidation process related to the AmDeck™ floor and roof system with best applied practices that have been acquired so far.

Amvic recommends reviewing parts 10 and 11 of the Amvic ICF Technical and Installation Manual which cover a variety of subjects related to AmDeck™ including concrete fundamentals, pouring and consolidation.

8.2 – Pre-pour Checklist

Before placing the concrete, it is essential to review a pre-pour checklist. Some of the primary checks include but not limited to the following:



Tip

Extra copies of the following checklist should be made to ensure everything is in order prior to pouring concrete.

- Is the AmDeck™ floor system level and at correct elevation?
- Does reinforcing steel type and placement conform to the engineering drawings/specifications and/or local building code requirements?
- Are all the details for reinforcing steel splices and connections to the other building structural systems installed in accordance with engineering drawings/specifications and/or local building code requirements?
- Have all structural attachments for suspended ceiling (if required) been installed?
- Is shoring installed properly and erected in accordance with engineering specifications and/or building code requirements?
- Have AmDeck™ End Covers or other suitable material been used to plug the openings in the forms?
- Have all utility and service penetrations/block outs been accommodated?
- Has the delivery time for both the boom pump and concrete been coordinated and confirmed.
- Are there two mechanical vibrators on the job site – (one as a back-up)?
- Is adequate labor prepared for pouring?
- Is the site clean, and is there enough room for trucks, workers, etc.?



8.3 – Safety tips for handling and placing concrete

The following suggestions, precautions and safety measures are recommended for anyone handling wet concrete:

- Always wear a hard hat for head protection on a construction site.
- Protect your skin. Wet fresh concrete is very abrasive to the skin. It can cause skin irritations, chemical burns and prolonged contact can cause third degree burns. It is therefore recommended to:
 1. Wear waterproof gloves, long sleeve shirt, long pants and rubber boots.
 2. Use waterproof pads to protect your skin, knees, elbows and hands from contact with fresh concrete during finishing.
 3. Flush eyes and skin that come in contact with fresh concrete immediately with clean water.
 4. Rinse clothing saturated from contact with fresh concrete with fresh water.
- Protect your eyes. Wear full cover goggles or safety glasses with side shields during the concrete pour.



8.4 – Concrete specifications for AmDeck™

The following table provides suggested concrete mix specifications to be used with AmDeck™ floor and roof system. This table is only a guideline and the design engineer may choose to deviate from these values as required.

Specification Description		Value
Minimum 28 day compressive strength, f_c' *		3500 Psi (24MPa)
Recommended Slump **	0 to 15 slope	5.5 in (140 mm)
	15 to 30 degree slope (roof)	3 in (76 mm)
	30 to 40 degrees slope (pitched roof)	2 in (50 mm)
Recommended max water to cement ratio W/C		0.55
Recommended max aggregate size		3/4 in (19mm)
Recommended air entrained %		3-5%
Recommended cement type ***		Type 10 Type 1

* Value given is the minimum recommended compressive strength.

** Slump values given are optimum for workability on the different slopes

*** Other types may be used with the consent and supervision of the design engineer

Table 8.1 - Guideline specifications for concrete mix

8.5 – Concrete Placement

8.5.1 - Crew Size

Assuming the concrete will be poured using a boom pump, a minimum crew of 4 is required on pour day. All of the crew members will be required on top of the deck; one handling the boom hose, one working the vibrator and two troweling/finishing the concrete surface as required.

8.5.2 - Pouring the Concrete

AmDeck™ is an open floor/roof system. Therefore the rate of pouring concrete per hour and the concrete mix slump are not considered critical factors during the pour as is the case with walls. Although this gives the contractor/installer some leeway, there are general guidelines that should be followed:



- 1 - Ensure that the AmDeck™ floor or roof is clean and free from any debris before the concrete pour.
- 2 - While pouring concrete, DO NOT pile or stack a load of concrete in any one place and try to move the pile to other areas using a shovel or wheelbarrow. Always pour the concrete as close as possible to where it will remain, which should be easy if using a boom pump.
- 3 - Avoid stepping directly over, or placing heavy equipment on the reinforcing steel bars or the service and utility pipes. Always use wooden planks to spread the load as you move from one place to another.
- 4 - When pouring concrete, start at one end of the floor or roof and work your way to the other end. Pouring in this sequence is a good practice as it allows the finishing crew to follow close behind.
- 5 - When pouring concrete, DO NOT fill the joists (beam) portion first and then pour the top slab at a later stage. **When placing concrete in a particular area, ensure that the joists and top slab are poured monolithically, with no cold joints between the two elements.**
- 6 - Unless otherwise specified by the design engineer, the whole area covered by AmDeck™ shall be filled with concrete in one continuous pour, with no construction or cold joints.
- 7 - Concrete shall be appropriately cured in place after the pour, as per engineering specifications and/or local building code requirements.
- 8 - Shoring shall not be removed until the poured concrete has gained its specified compressive strength.



Important Note

The design engineer may specify a pouring sequence for multiple spans of AmDeck™ which should be followed strictly.



8.5.3 - Quality Control

8.5.3.1 - Slump

Perform a field slump test on the first batch of concrete that arrives on the jobsite. If the slump is too low or too high, immediately inform the concrete supplier to adjust the concrete mix appropriately for the subsequent batches.



Figure 8.1 – Measuring concrete slump

8.5.3.2 - Compressive Strength

Amvic strongly recommends taking fresh random concrete samples for compressive strength testing at 28 days by a recognized independent laboratory. When tested, the samples should yield minimum results of not less than what was specified by the design engineer.

With a minimum specified concrete compressive strength of more than 2500 psi (17.2 MPa), special inspection by a qualified professional according to the local building codes may be mandatory.





Figure 8.2 – Preparing concrete cylinders for testing

8.6 – Consolidating the Concrete

8.6.1 - Consolidation Fundamentals

Consolidation is the process of compacting freshly poured concrete. Concrete **MUST** be consolidated to:

- 1 - Eliminate stone pockets, honeycomb, and entrapped air
- 2 - Mould concrete within the forms and around embedded items
- 3 - Ensure reinforcing steel is properly embedded and bonded to the concrete paste

8.6.2 - Methods of Consolidation

The concrete industry has accepted 2 types of concrete consolidation;

- 1 - Internal
- 2 - External



Internal Consolidation

Internal consolidation can be divided into 2 types;

- 1 - Mechanically, using proper size immersion type concrete vibrator (also known as poker or spud vibrators). This is the most preferred method for adequate consolidation.
- 2 - Manually using steel rods and “rodding” the concrete. This not a practical method for use with AmDeck™ and does not provide adequate consolidation of the concrete.



Important

Amvic highly recommends using a proper size concrete vibrator for adequate concrete consolidation. Using hand rodding to consolidate concrete on AmDeck™ should be AVOIDED.

External Consolidation

This method involves attaching a mechanical vibrating device to the outside of the AmDeck™ forms. Although this method may be acceptable, experience has shown it is not as effective as internal mechanical vibration.



Important Note

External vibration methods such as manually tapping on the outside of the forms are NOT ACCEPTED as an adequate means of consolidating concrete in AmDeck™ and must be AVOIDED.



8.7 – Using Concrete Vibrators

8.7.1 - Recommended Specifications

Vibrators consist of a vibrating head connected to a driving motor by a flexible shaft. Inside the head, an unbalanced weight connected to the shaft rotates at high speed, causing the head to revolve in a circular orbit. The motor can be powered by electricity, gasoline, or air. The vibrating head is usually cylindrical with a diameter ranging from 3/4 to 7 inches (20 to 180 mm). The dimensions of the vibrator head as well as its frequency and amplitude in conjunction with the workability of the mixture affect the performance of a vibrator.



Figure 8.3 – Immersion type concrete vibrator

The table below states the recommended specifications for concrete vibrators to be used with AmDeck™.

Specification	Value
Maximum vibrator head diameter	1.5 inch (38 mm)
Frequency (vibrations per minute)	9000 vpm
Minimum Radius of Action	6 inch (152 mm)
Insertion on center spacing	9 inch (229 mm)
Centrifugal Force	550 lbs (250 kg)
Compaction Rate	3 to 6 cu. yds/hr (2.3 to 4.6 cu. m ³ /hr)

Table 8.2 – Recommended immersion type concrete vibrator specifications for use with AmDeck™



8.7.2 - Guidelines for Concrete Consolidation

Recommended Practices;

- Consolidation **MUST** be done immediately after fresh concrete is poured and before it sets.
- Completely immerse vibrator head in concrete during consolidation.
- Insert vibrator vertically and let it sink as **quickly** as possible under its own weight to the desired depth, as illustrated in Figure 8.4 below.

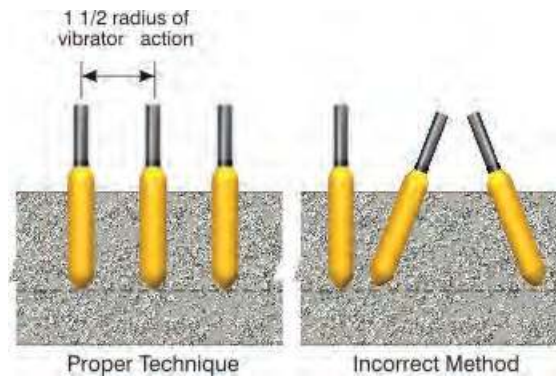

Figure 8.4 – Vibrator head placement



- Move vibrator and re-insert at a distance 1.5 times the radius of action as shown in figures 8.5 and 8.6 below.

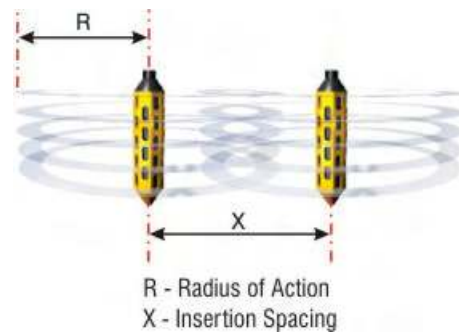

Figure 8.5 – Radius of action of concrete vibrator

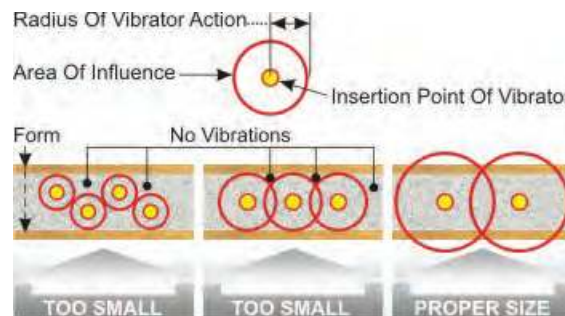

Figure 8.6 – Insert vibrator head at 1.5 times radius of action

- Stop vibration when the surface becomes shiny and there are no more breaking air bubbles.



Practices to Avoid;

- Do not use vibrator to move concrete laterally. This causes segregation.
- The vibrator head should not touch the steel reinforcement. It should only come in contact with the concrete.
- Do not immerse the vibrator head down the same path more than once.
- Do not run the vibrator in air for more than 15 seconds. This will cause overheating.
- Avoid sticking the vibrator head into the top of a concrete heap. To flatten a concrete heap, insert the head around the perimeter. Do this carefully to avoid segregation.

8.8 – Finishing the Concrete Pour**8.8.1 - Overview**

Finishing refers to screeding, floating or troweling the concrete surface to provide further compaction of the surface and the type of surface required. Finishing has two stages: initial and final. The concrete surface may require finishing as per engineering specifications that could include a floated, troweled or broomed finish. In the following section the typical steps involved in finishing are discussed.

8.8.2 - Stage 1: Initial Finishing

1. **Screeding:** Screeed or strike-off concrete to bring the slab to the proper level if there is an excess of concrete in particular areas. Any bleed water that appears should be left to dry up. Do not try to eliminate the bleed water by using stone, dust or cement, since this will weaken the concrete surface.





Figure 8.7 – Screeding

2. **Bullfloating:** After the bleed water disappears, bullfloating is performed. Bullfloating eliminates surface ‘up and down’ unevenness and embeds any large aggregates into the concrete. Additionally, bullfloating helps to seal concrete from moisture loss.

The most common sizes for bull floats are 8 inches in width and between 42 inches (1.07 m) and 48 inches (1.22 m) in length. The bull float handle is usually 5 to 6 feet (1.53 to 1.83 m) in length. The parts comprising the handle are extendable, so that concrete areas that are out of reach can be accessed. Bull floats are composed of either aluminum or magnesium

8.8.3 - Stage 2: Final Finishing

1. **Bullfloating:** Bullfloating, which was part of stage one, may be repeated if required.

Power or Hand Floating: The concrete is also floated with a wood or metal hand float, or a finishing machine that uses such blades (power-floating). This helps embed any aggregate and rough spots and close minor cracks. Note that power floating leaves a finish superior to hand floating.

2. **Checking Levels:** The concrete levels must now be checked and they must fall to within specified tolerances.





Figure 8.8 – Stage 2: Final Finishing of Concrete on AmDeck™



3. **Power-trowel or Final Hand Trowel:** A power-trowel or a final hand trowel finish are conducted to ensure that plane surface tolerances are achieved, as per specifications. The final surface should be a smooth, hard, dense and free from any trowel marks. This step should be done twice.
4. **Broom Finishing:** For producing a slip-resistant surface, the concrete can be broom finished while the concrete surface is still not completely hardened, so as to create the slip-resistant grooves (straight lines, or s-shaped).

8.9 – Concrete Curing

8.9.1 - Overview

In order to develop the strength of the placed concrete it is necessary to cure it. Curing refers to keeping the concrete moist, so that the bond between the paste and aggregate gets stronger. Curing is very important, as it makes the concrete more durable, less susceptible to cracking and stronger.

Curing begins after final finishing and after concrete has hardened (initial setting). In hot weather (30° C/86° F), high winds or low humidity, extra precautions must be taken to ensure that the concrete does not dry out.

8.9.2 - Methods of curing

8.9.2.1 *Applying Water*

A fine mist of spray can be applied to the concrete surface. The spray must be fine so that it will not damage the concrete. Keep concrete moist at ALL times during the curing period.

8.9.2.2 *Wet Sheets*

Wet sheets, which may be of cloth or plastic are an easy and low-cost method to cure concrete. The concrete may be either wetted and then covered with plastic, or if a cloth is used, then the overlying cloth must be wetted at regular intervals. The sheets must be held down by placing an appropriate weight over them. Ensure that the concrete surface is evenly moist, otherwise, some parts may become darker than others. Condensation under plastic sheets is a good sign of adequate curing.



8.9.2.3 - Curing Compounds and Retarders

Curing compounds slow down the rate of water loss in concrete. The curing compound is added into the concrete as part of the concrete mix. Read the manufacturer's instructions if these are used.



Note

Some compounds may not be compatible with the concrete finishes specified on a project, such as paint or coverings that will be attached using adhesives.

Evaporation retardants also perform a similar function as curing compounds. They reduce rapid loss of surface moisture, which, in turn, reduces the possibility of early plastic concrete shrinkage. The difference between retardants and curing compounds is that the retardants must be applied after initial screeding and floating, and then again after each finishing process. Severe weather conditions also require re-application. Consequently, retardants have a temporary effect and once the concrete is finished, standard curing techniques must still be applied.



Moisture Control

The amount of water absorbed by the EPS form blocks is less than 3.0% of the volume of the block. However, water may enter into the cavities of the AmDeck blocks during the construction phase from the two open ends of the form block. It is the responsibility of the installer to make sure that during the construction phase the blocks are emptied of rainwater and the forms are kept dried. If the water gets into these cavities anytime during construction, the floor system must be completely dried and moisture free prior to the attachment of finishing building materials on either side of the system.

8.9.2.4 - Duration of Curing

Amvic recommends curing for at least 7 days.





Part 9 – Interior & Exterior Finishes

9.1 – Overview

AmDeck™ is a reinforced concrete floor or roof system. As such, any exterior finishing material that can be applied to concrete may also be applied to AmDeck™. On the interior (soffit) side, the AmDeck™ system leaves a flat EPS and metal stud surface which can be finished using materials that conform to architectural and local building code regulations. This part of the manual will discuss the exterior and interior finishes most commonly used with AmDeck™ in detail.

9.2 – Exterior Finishing (applied to the concrete side)

9.2.1 - Finishing Materials Added on Top of Concrete

Laminate floors: The laminate floor systems come in two types: adhesive or non-adhesive. The non-adhesive types interlock with each other and float over a foam pad.

Hardwood floors: Before installing hardwood flooring, test and ensure that the moisture level within the concrete is within acceptable levels. A vapor barrier is installed over the concrete to control any additional moisture reaching the hardwood. A sub-floor usually made of plywood is installed over the vapor barrier and attached to the concrete using power actuated fasteners. The hardwood flooring tiles may then be installed over the plywood sub-floor using blind nails.

Ceramic Tiles: Adhesive or mastic is applied to the concrete floor, tiles are laid, then grout is applied between the tiles, as per manufacturer's instructions.

Vinyl Sheet: This is affixed to the concrete deck by adhesives according to the manufacturer's specifications.

Marble / Granite: Marble/granite floor tiles can be directly installed on top of the AmDeck™ concrete surface. The installer must ensure that the concrete surface is flat and smooth to within acceptable tolerances for this type of flooring. Thin-set cement is commonly used to fix the tiles in place and the joints in between are filled with grout.



Note

Ensure to follow flooring manufacturers recommended installation procedure for any flooring materials used with AmDeck™.



Carpet: To install carpeting, an adhesive must be applied to the concrete surface. Follow the manufacturer's instructions with respect to the usage of any primers and patching compounds, air and concrete surface temperatures suitable for the application of the adhesive, and acceptable concrete surface moisture levels.

9.2.2 - Decorative Finishes Applied to Concrete Surface

Chemical Staining

Concrete can be stained by adding special chemicals which interact with its lime content. The color is bonded into the concrete surface through light etching. Results however, may vary due to weathering, surface texture, or exposure to chemicals. Mottling, which is an outcome of this process, helps create concrete's resemblance to granite, marble, or to highlight the particular concrete's texture. Various effects on the concrete surface can be achieved using brushes, mops, leaves, rags etc. The full effect of the color may not be noticeable until waxes and sealers are applied.

Wax and Sealers

Sealing and waterproofing the finished concrete surface is done using clear or colored sealer or wax. Clear sealer coatings bring a depth and shine to the pre-existing chemical staining effects. Maintenance may involve re-sealing or re-waxing, or periodically mopping of the surface with floor wax.

Colored Concrete

Integral Coloring

A liquid or powdered colorant may be added to the concrete during its mixing process to produce a uniform tint.

Colored Hardeners

Hardening agents are powders consisting of colored, finely-ground cementitious aggregates that are spread onto freshly placed concrete. For standard 4 inch concrete, surface strength may be increased up to 7000 psi. Since the colorant is concentrated in the top layer, the hue it produces may be darker. To improve durability, hardeners may be used



just before stamping or chemical staining, producing brighter and deeper colors.

Stamping

Stamping is a technique in which rigid or flexible patterns are used to imprint the outline and textures of stone, brick, tile, wood planks etc. into the freshly cast concrete surface. Imprinting tools may be stones or a group of stones approximately 2 ft x 4 ft (.61 m x .61 m). Grout may be applied to grooves for a more realistic appearance. Colored release agents are often recommended to reduce friction and facilitate the removal of patterns from fresh concrete. The colored release agents may also complement colored hardeners to produce a mottled patina (antique look) on the concrete surface.

Scoring

Scoring refers to shallow cuts not more than $\frac{1}{8}$ inch (3.2 mm) deep that are made into the concrete surface to mimic geometric patterns or tile groove lines. The cuts can be made using a regular circular saw with a masonry blade.

9.3 – Interior Finishing (Soffit Side)



Moisture Control

The amount of water absorbed by the EPS form blocks is less than 3.0% of the volume of the block. However, water may enter into the cavities of the AmDeck blocks during the construction phase from the two open ends of the form block. It is the responsibility of the installer to make sure that during the construction phase the blocks are emptied of rainwater and the forms are kept dried. If the water gets into these cavities anytime during construction, the floor system must be completely dried and moisture free prior to the attachment of finishing building materials on either side of the system.

9.3.1 - Drywall

Currently, all building code models in North America require foam plastics to be separated from interior living spaces, any habitable spaces and some crawl spaces, by a



thermal barrier (fire protection) that will remain in place for 15 minutes, based on specific testing criteria.

The most common type of interior finish material that will meet the thermal barrier requirements as stipulated by the building codes is a 1/2 inch (12.7mm) gypsum board, also known as drywall.

The AmDeck™ system utilizes 10 inch deep (254 mm) lightweight steel framing joists, located at 16 inches on center (406.4 mm) to which the drywall can be directly screwed. The spacing and size of the screws for this attachment should follow the local building code requirements.

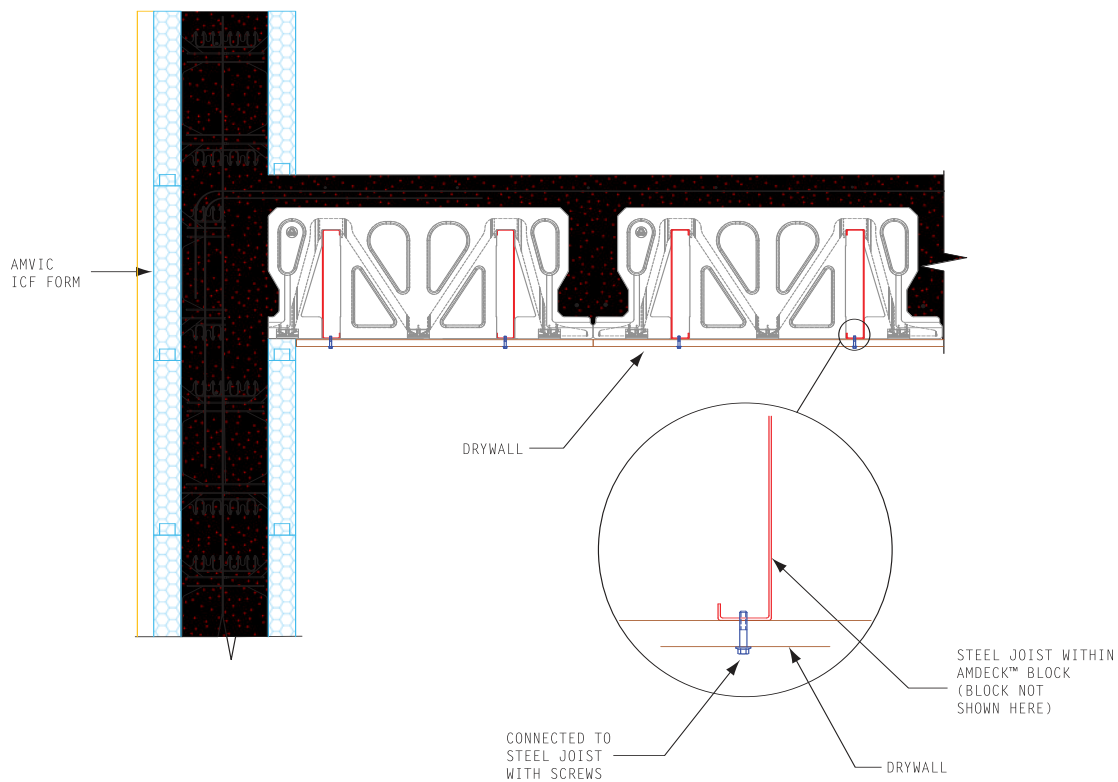

Figure 9.1 - Drywall Connection to AmDeck™



9.3.2 - Traditional Stucco

Traditional three coat stucco for insulating forming systems is mainly composed of metal wire lathe, a base coat and a finish coat. The metal wire lathe shall be screwed to either the 10 inch metal joists or to the propylene web embedded in the AmDeck™ blocks using regular drywall fine or coarse thread screws.



Note

Installers may prefer to screw the metal wire lathe to the propylene webs and remove the steel joists in order to reduce construction costs. In such a case, the steel joists shall not be embedded into the walls or other structural elements of the buildings as described in Part 7, so that they can be removed easily AFTER the concrete has gained the specified compressive strength.

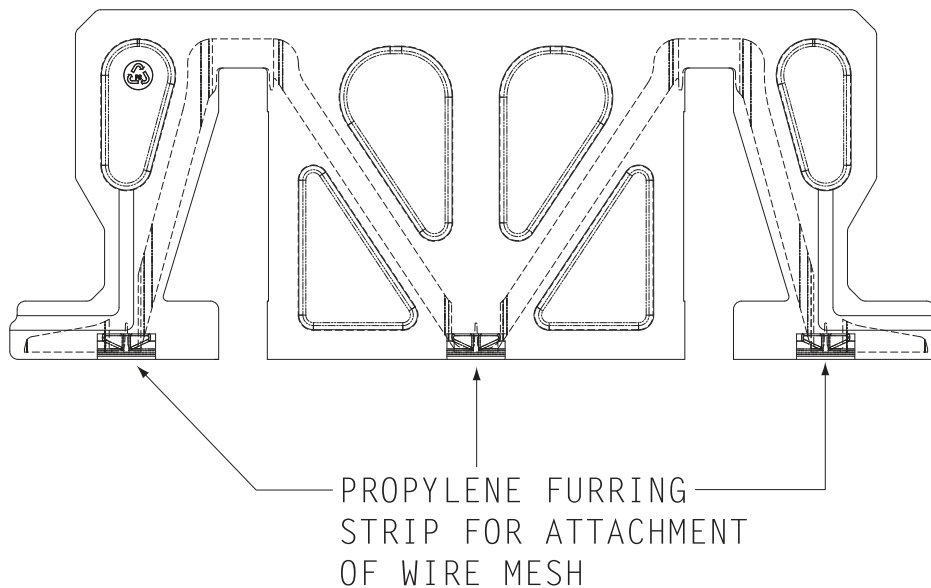

Figure 9.2 - Furring strips on AmDeck™



9.3.3 - Drop Ceiling Panels

There are two methods to attach drop ceilings as discussed below: (Please also refer to section 6.9.1 for detailed discussions on drop ceiling connections).

1 - Drop ceiling attached to concrete



Figure 9.3 - Attaching drop ceiling to concrete joists with hooked steel hanger rods



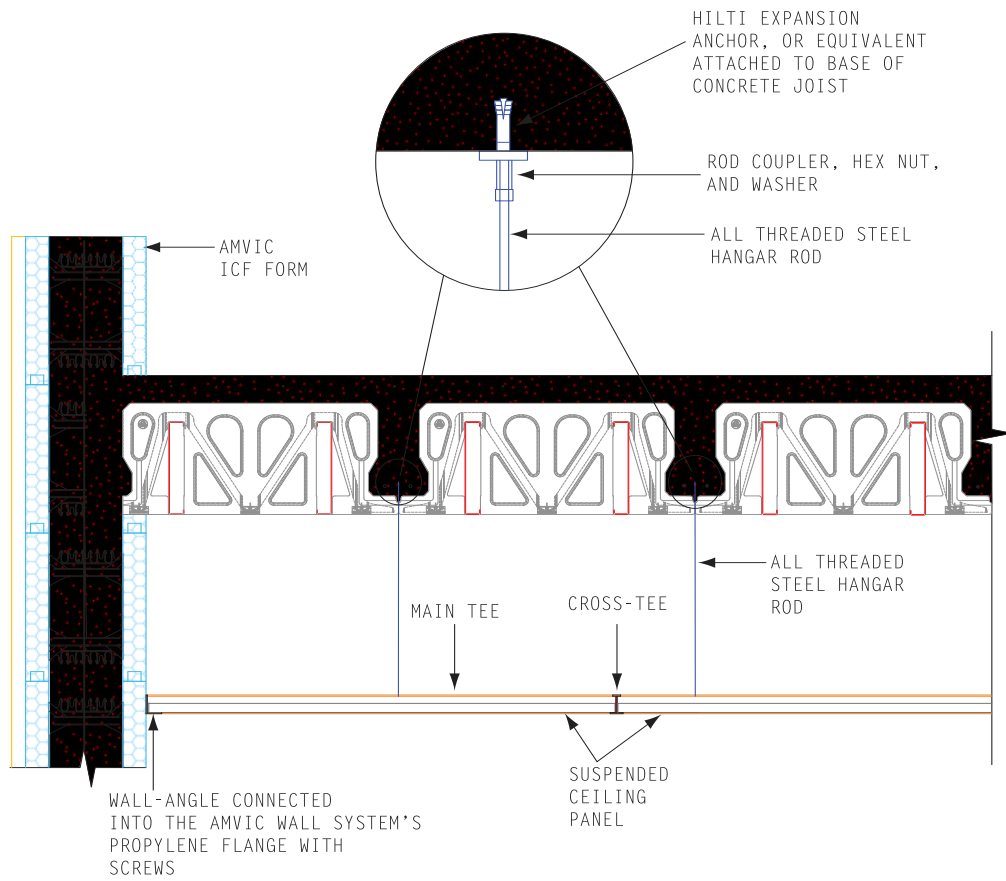

Figure 9.4 - Attaching drop ceiling to concrete joists with expansion anchors



2 - Drop ceiling attached to steel joists

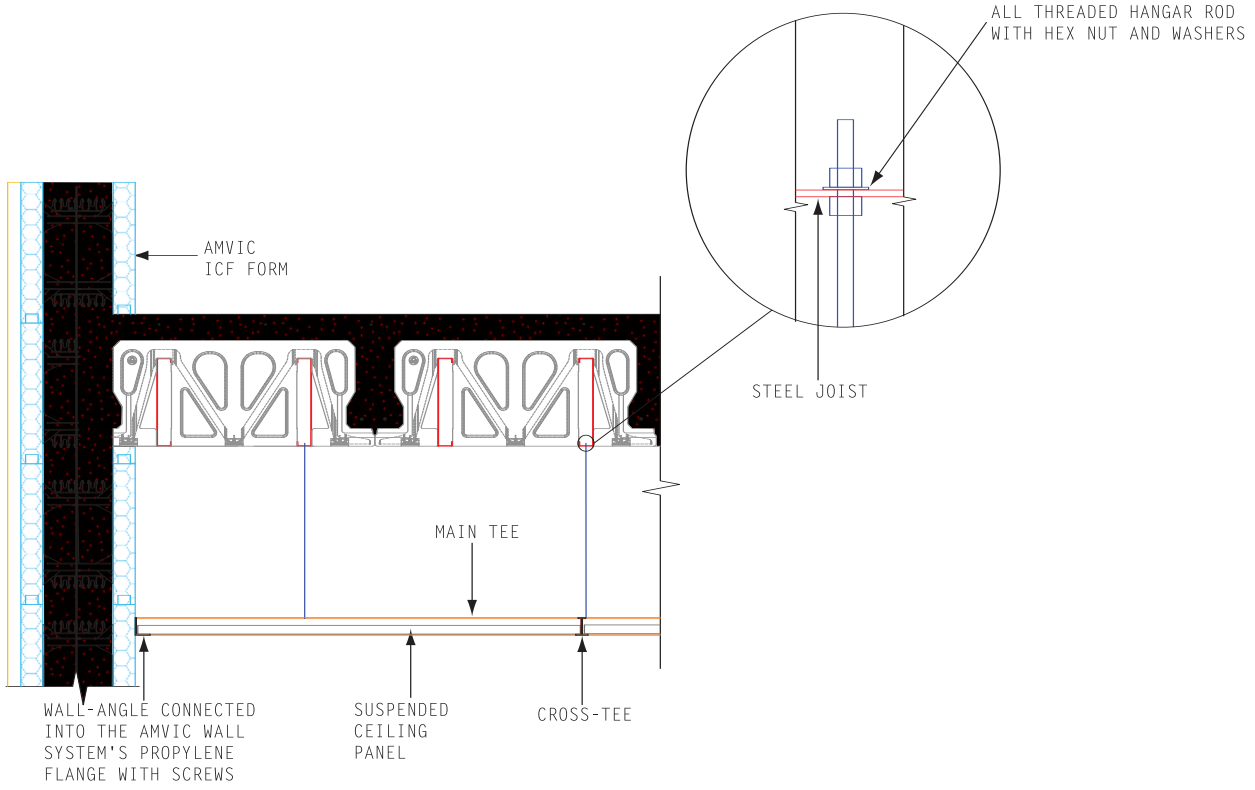

Figure 9.5 - Attaching drop ceiling to steel joists



Note

If the Amvic ICF wall system is being used, the wall angles/L-channels are connected to the flange of the propylene web of the wall system, using approved drywall fine thread or coarse thread screws as shown in Figure 9.5 above.



9.4 – Roof finishes

There are many types of roofing systems that can be applied to AmDeck™.

The architect would typically specify the most appropriate system to be used depending on the application and project at hand. Regardless of which system is being used, the installer must always follow the roofing manufacturer's installation manual.

Below, is a brief discussion of the most common types of roofing systems used.

9.4.1 - Overview: Built-Up-Roofing for AmDeck™

The major components of the Built-Up Roofing system (BUR) for concrete decks are the membranes, fastening systems, and flashing. Figure 9.6 depicts a typical BUR. The BUR system must be placed as per engineering specifications and/or local building codes. Site inspections under the supervision of a qualified professional are an integral part of ensuring quality control during the installation of the system. In the following sections, the main properties of the components of BUR are discussed.

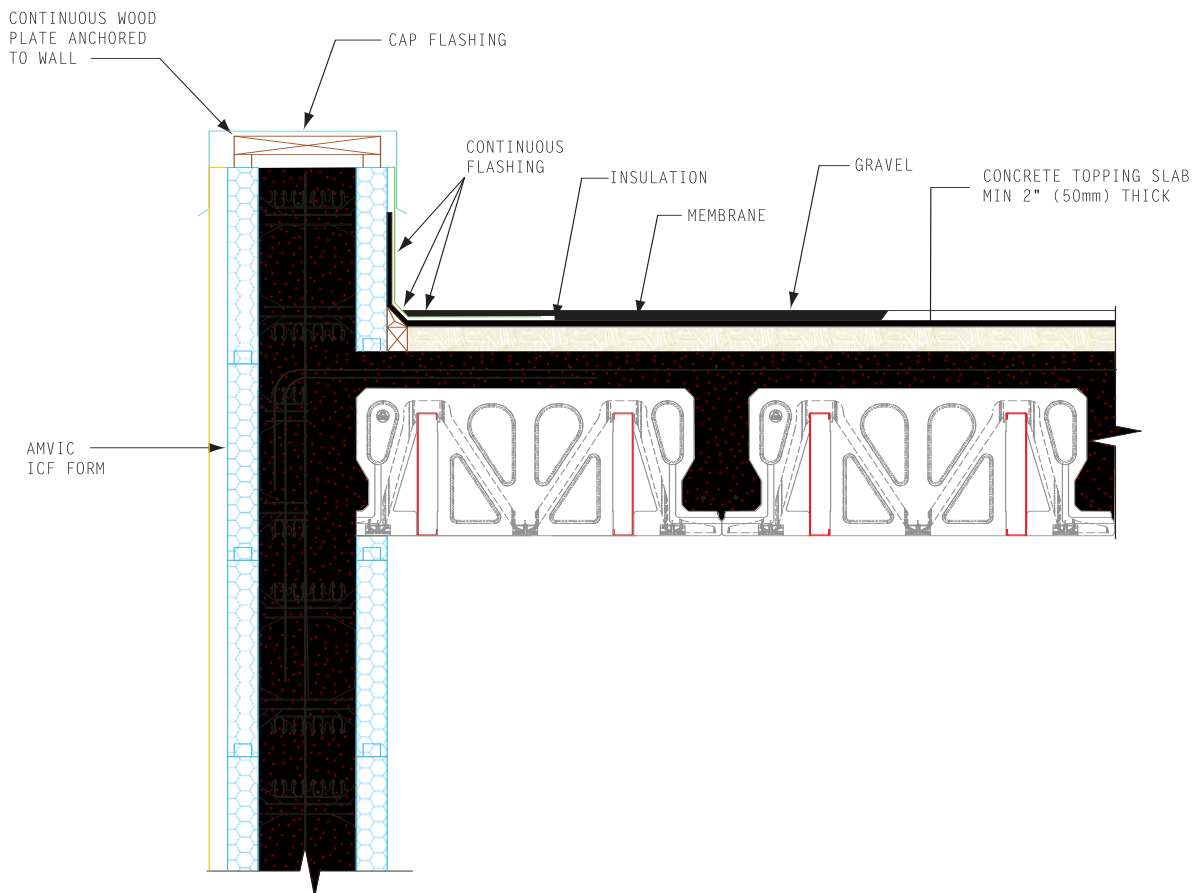

Figure 9.6 – A “Built-Up Roof”: Single-ply membrane system on AmDeck™ roof



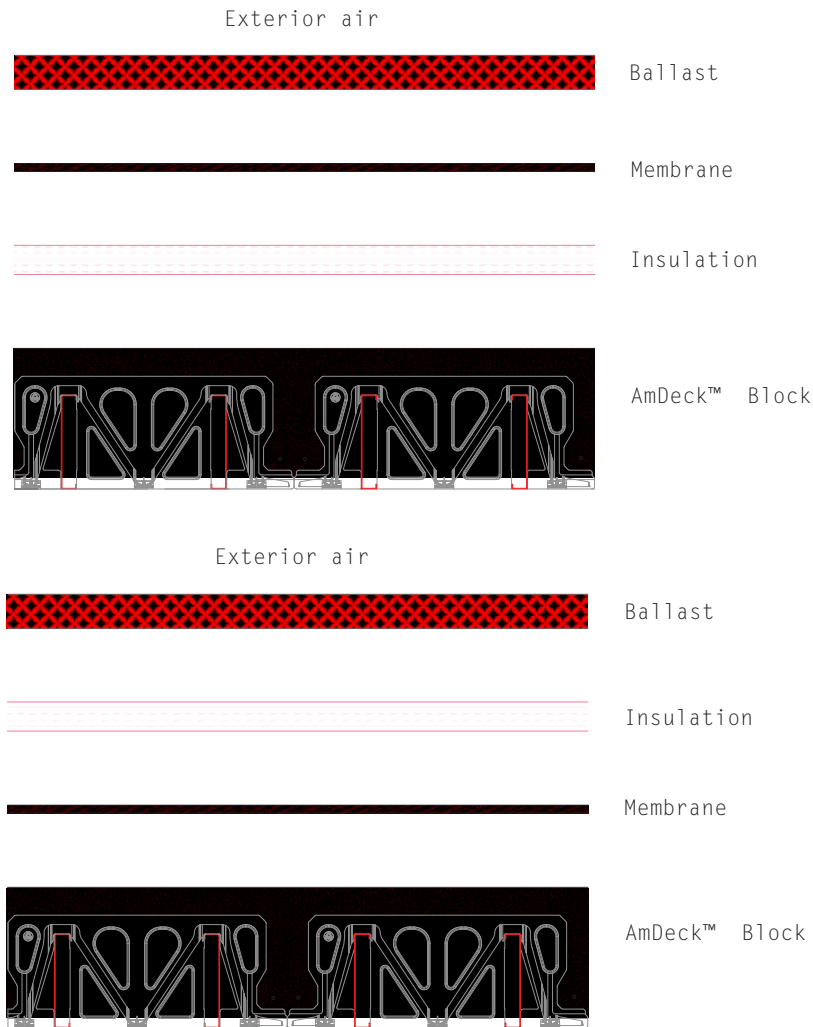

Figure 9.7 – Types of Single-ply membrane system on the AmDeck™ roof:
 Membrane on top of insulation and membrane below insulation

9.4.2 - Membranes Systems

9.4.2.1 - Felt Roofing

The most common flat (low-slope) roofing system is the Built-Up-Roofing consist of three to five roofing felts. The felts are composed of a mat made from organic or inorganic fibres. The most common types are the organic rag felts. These comprise of wood fibre pulp, with some scrap paper and a small amount of rag. Glass fibre mats are also used. Roofing felt is saturated and often coated with bitumen. The felts are joined to each other by hot asphalt and capped with hot asphaltic membrane and gravel ballast. The felts stabilize and prevent bituminous films from being ruptured, and also help to reinforce the roof covering. The bitumen provides adhesion and waterproofing.



9.4.2.2 - SPF Membranes

Sprayed polyurethane foam membranes (SPF) contain isocyanate and polyol. The two components are mixed in a device called a proportioner which is then sent to a spray gun. The resulting mixture is spread onto the concrete substrate. Since SPF is spread onto the roof substrate as a seamless liquid, an elastomeric base coat is applied, followed by a topcoat for protection.

9.4.2.3 - Polymer Modified Bitumens

Polymer modified bitumen membranes can be applied through self-adhering sheets, hot asphalt or heating the membranes with a torch. The self-adhering sheets are coated with modified asphalt and protected by a laminated polyethylene sheet to prevent self-adhesion in the roll. The protection sheet is peeled off or melted away during application. A propane torch is used to melt the asphalt on the underside of the roll. Seams are sealed by torch-welding or by applying hot asphalt.

If a single ply bitumen system is used, ballast, in the form of gravel comprising rounded stones, is laid onto the deck to resist uplifting wind forces. Concrete pavers may also be used, provided that they are not abrasive and will not rupture the membrane.

9.4.2.4 - EPDM single ply membranes

Ethylene Propylene Diene Monomer (EPDM) is a single ply prefabricated membrane sheet that is designed to resist water penetration.

The membrane can be ballasted, laid loosely, chemically adhered or mechanically fastened. If mechanically fastened, it is held in place by screws and stress plates. A bonding agent is used to adhere the EPDM to the concrete substrate.

9.4.2.5 - Other types of membranes

Other membranes may be comprised of: PVC, Hypalon, Reinforced varieties, neoprene, SPF, Butyl and PVF.

9.4.2.6 - Insulation

Insulation protects the membrane if applied on top. Alternatively, the membrane may be placed over the insulation. Insulation types include: extruded and expanded polystyrene, fiberglass, polyisocyanurate, fibreboards, perlite boards and foamed urethanes.



9.4.2.7 - Fastening/ballast Systems

The purpose of these fastening/ballast systems is to protect the roofing membrane from deterioration due to solar rays, by reflecting sunlight, and to provide a weight which prevents the felt from being uplifted due to high winds. For complete coverage, the ballast size is important. If the gravel size is too large, then there will be gaps. If it is too small, then it may be blown away due to the wind or become easily displaced.

The most common surfacing ballast material is gravel and slag, which ranges in size from 1/4 to 5/8 inches (6 mm to 16 mm). Other ballast or fastening systems include: stone, marble chips, crushed brick chips, crushed volcanic rock, crushed limestone, heavyweight pavers, lightweight interlocking pavers, composite insulation and ballast, concrete tiles with ship-laps, spot fasteners, adhesives, bar straps and anchors.

9.4.2.8 - Flashing Systems

Various flashing systems, for base, cap and counter flashing, such as rubberized asphalt sheet flashing and pre-finished sheet-metal flashing may be used to protect the membrane edges and termination points.

