

BROAN®

USER GUIDE FOR BROAN ERV100S AND ERV100SP

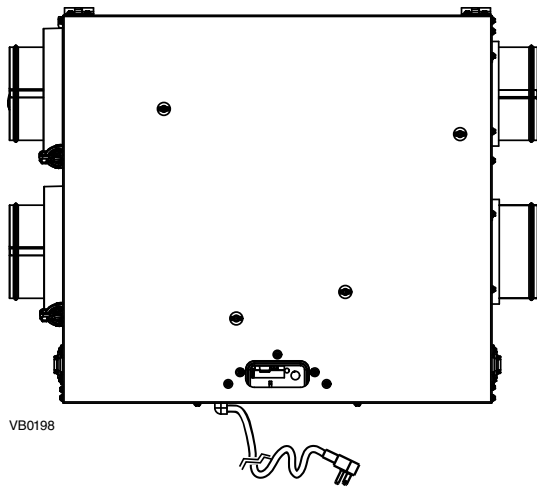

Model ERV100S

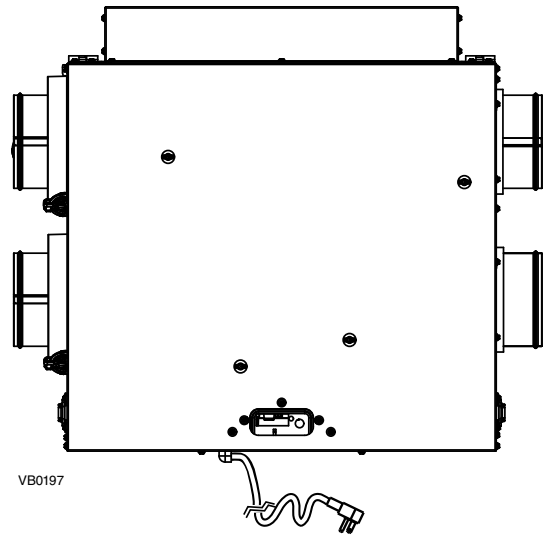

Model ERV100SP*



*This product earned the ENERGY STAR® by meeting strict energy efficiency guidelines set by Natural Resources Canada and the US EPA. They meet ENERGY STAR requirements only when used in Canada.

⚠ RESIDENTIAL USE ONLY ⚠

**READ AND SAVE THESE INSTRUCTIONS
INSTALLER: LEAVE THIS MANUAL WITH HOMEOWNER**

Broan-Nutone LLC; Hartford, Wisconsin www.broan.com 877-862-7626

REGISTER YOUR PRODUCT ONLINE AT: www.broan.com/register

For additional information - visit www.broan.com



7 72371 13566 6

Thank you for buying a Broan unit!

We have prepared this User Guide especially for you. Please read it carefully to ensure you obtain full benefit from your ERV. Please take note that this manual uses the following symbols to emphasize particular information:

⚠ WARNING

Identifies an instruction which, if not followed, might cause serious personal injuries including possibility of death.

CAUTION

Identifies an instruction which, if not followed, may severely damage the unit and/or its components.

NOTE: Indicates supplementary information needed to fully complete an instruction.

We welcome any suggestions you may have concerning this guide and/or the unit, and we would appreciate hearing your comments on ways to better serve you. Please forward all correspondence to us at the address indicated on the product registration card included with this guide.

CAUTION

Make sure at all times that the outdoor intake and exhaust hoods are free from any snow during the winter season. It is important to check your unit during a big snow storm, so it doesn't draw in any snow. If this is the case, please operate the unit in recirculation mode (if available), or turn it OFF for a few hours.

Do not use your unit during construction or renovation of your house or when sanding drywall. This type of dust may damage your system.

Since the electronic control system of the unit is incorporated with a microprocessor, it may not operate correctly because of external noise or very short power failure. If this happens, unplug the unit and wait approximately 10 seconds. Then, plug the unit in again.

When leaving the house for a long period of time (more than two weeks), a responsible person should regularly check if the unit operates adequately.

If the ductwork runs through an unconditioned space (e.g.: attic), the unit must operate continuously except when performing maintenance and/or repair. Also, the ambient temperature of the house should never drop below 65°F.

At least once a year, the unit mechanical and electronic parts should be inspected by qualified service personnel.

REPLACEMENT PARTS AND REPAIR

In order to ensure your ventilation unit remains in good working condition, you must use Broan-Nutone LLC genuine replacement parts only. The Broan-Nutone LLC genuine replacement parts are specially designed for each unit and are manufactured to comply with all the applicable certification standards and maintain a high standard of safety. Any third party replacement part used may cause serious damage and drastically reduce the performance level of your unit, which will result in premature failing. Broan-Nutone LLC also recommends to contact a Broan-Nutone LLC certified service depot for all replacement parts and repairs.

TABLE OF CONTENTS

1. DEFROSTING MODES	3
2. CONTROLS	4-5
2.1 ERV100SP BOOTING SEQUENCE	4
2.2 ERV100S BOOTING SEQUENCE	4
2.3 BLINKING LED	4
2.4 ERV100SP INTEGRATED DEFROST CONTROL	5
2.5 ERV100S INTEGRATED CONTROL	5
2.6 SETTING EXTENDED DEFROST FOR ERV100S UNIT	5
2.7 MAIN AND AUXILIARY CONTROLS	5
3. MAINTENANCE	6-7
3.1 QUARTERLY MAINTENANCE	6-7
3.2 ANNUAL MAINTENANCE	7
4. TROUBLESHOOTING	8

1. DEFROSTING MODES

When the outdoor temperature is below 14°F, recovery of energy creates frost in the core.

To maintain its proper operation, the unit is programmed to defrost the energy recovery core.

For ERV100S model, during the defrost cycle, the unit keeps the same speed but stops to supply fresh air.

For ERV100SP model, during the defrost cycle, the dampers close but the unit speed can be set on high or low, according to your needs. See point 2.4 for more details.

After defrosting, the unit returns to the operating mode selected by the user.

2. CONTROLS

2.1 ERV100SP BOOTING SEQUENCE

The unit booting sequence is similar to a personal computer booting sequence.

Each time the unit is plugged after being unplugged, or after a power failure, the unit will perform a booting sequence before starting to operate.

During the booting sequence, the LED located on the unit door (**A** in illustration below) will be OFF for 3 seconds, and then will turn RED for the rest of the booting sequence (approximately 30 seconds). During this RED light phase, the unit is checking and resetting the motorized damper position.

Once the motorized damper position completely set, the booting sequence is done; the color of the LED will show on which defrost cycle the unit is set.

NOTE: No command will be taken until the unit is fully booted.

2.2 ERV100S BOOTING SEQUENCE

The unit booting sequence is similar to a personal computer booting sequence.

Each time the unit is plugged after being unplugged, or after a power failure, the unit will perform a booting sequence before starting to operate.

During the booting sequence, the integrated control LED located on the unit door (**A** in illustration at right) will light up and remain GREEN or AMBER for 3 seconds, and will then shut off*; the booting sequence is done.

* or will light the color of the previous mode to show the unit resume to it, if the unit is controlled by its integrated control.

NOTE: No command will be taken until the unit is fully booted.

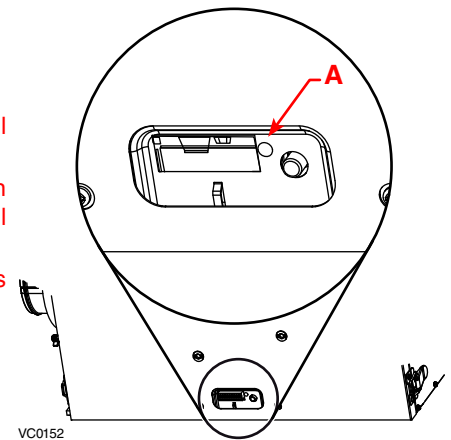

2.3 BLINKING LED

If a problem occurs during the unit operation, or if the unit turns in Protection mode*, its integrated control LED (**A**) will blink. The color and pattern of the blinking light depends on the type of error detected, or if running in Protection mode. Refer to the sticker on the unit and to Section 4 Troubleshooting for further details.

* All units are equipped with an electronic supplemental protection, called Coldshield™ Protection, to stop air distribution in dwelling if air distribution temperature drops below freezing point, due to abnormal conditions.

2. CONTROLS (CONT'D)

2.4 ERV100SP INTEGRATED DEFROST CONTROL

After the booting sequence is done, the LED (A) will light and stay lit to show in which defrost cycle the unit is set. Use the push button (B) to change the defrost cycle of the unit (see table below).

LED COLOR	DEFROST CYCLE
GREEN	STANDARD
RED	PLUS
AMBER	DISCRETION

NOTE: There is a 15-minute delay for the new defrost cycle choice to be kept in memory; if a power failure occurs during this time delay, when the power returns, the unit resume to its previous setting.

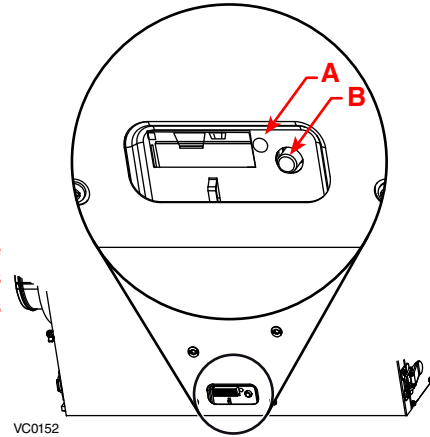

According to your needs, there are 3 defrost cycles available:

STANDARD: This is the factory set defrost cycle. This mode is the most efficient used to suit HVI and ENERGY STAR® performance. When needed, the unit will perform defrost cycle on high speed.

PLUS: This mode has been created for people who live in cold region (outdoor temperature -17°F and lower). This setting makes the unit perform defrost cycle on high speed for a longer period of time.

DISCRETION: When needed, the defrost cycle will be performed on the same speed than the unit ventilation speed. This means that if the unit is set on high speed, the defrost cycle will be done on high speed, but if the unit is set on low speed, the defrost cycle will be done on low speed.

2.5 ERV100S UNIT INTEGRATED CONTROL

Use the push button (B) to control the unit. The LED (A) will then shows on which mode the unit is in. Refer to table at right.

NOTE: When using main control, the integrated control must be turned off (no light from LED).

LED COLOR	RESULTS
AMBER	UNIT IS ON LOW SPEED
GREEN	UNIT IS ON HIGH SPEED
No LIGHT	UNIT IS OFF OR CONTROLLED BY A MAIN CONTROL

2.6 SETTING EXTENDED DEFROST FOR ERV100S UNIT

These units are factory set to normal defrost. In cold region (outdoor temperature -17°F and lower), it may be necessary to setup extended defrost. During the first 3 seconds of booting sequence, the integrated control LED shows the current defrost mode (refer to table at right).

LED COLOR	DEFROST MODE
GREEN	NORMAL
AMBER	EXTENDED

Within the first 3 seconds of booting sequence, press on push button until the LED starts to blink, then release the push button; the LED will blink AMBER 5 times. After that, the LED will shut off, then turn RED (the unit returns in its booting sequence).

2.7 MAIN AND AUXILIARY CONTROLS

The ERV100SP unit must be controlled by a main control. For more convenience, the ERV100S unit can also be controlled using an optional main control. Only one main control can be connected per unit.

NOTES: 1. The integrated control must be turned OFF on ERV100S model to use a main control.

2. If an optional auxiliary control is used, if activated, the operation of this auxiliary control will override the optional main control operation.

For more information about your unit controls, refer to the *Main and auxiliary wall controls user guide* (included with your unit and also available at www.broan.com).

3. MAINTENANCE

⚠ WARNING

Risk of electric shock. Before performing any maintenance or servicing, always disconnect the unit from its power source. When cleaning the unit, it is recommended to wear safety glasses and gloves.

3.1 QUARTERLY MAINTENANCE

1. Turn off and unplug the unit.
2. Open the unit door by unlatching its both side latches.

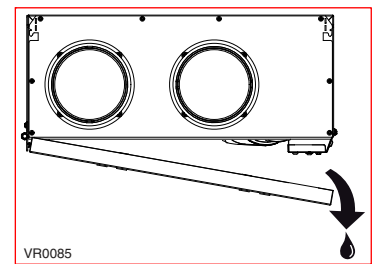
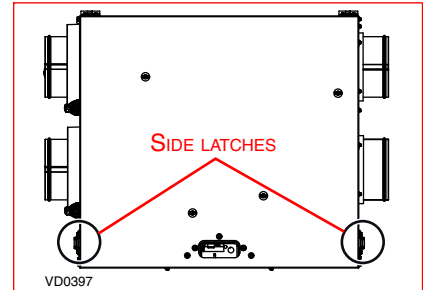

CAUTION

Be careful when opening the door; water may be present when outdoor temperature is cold.

3. While retaining the core (❶), loosen the wing nut (❷) and rotate the core retaining bracket (shaded part in illustration at right) to disengage it from the core flange. Slide out the core with its filters.

⚠ WARNING

Always hold the core when rotating the core retaining bracket; failure to do so will cause the core to fall out.

4. Clean the inside walls and door of the unit with a damp cloth, then wipe with a clean dry one.
5. Remove both filters from core top and wash them under hot water with mild soap. Rinse thoroughly and let dry completely before reinstalling on the core.
6. Remove the dust on the core using a vacuum cleaner and a soft brush attachment.

CAUTION

Do not soak the recovery core in water!

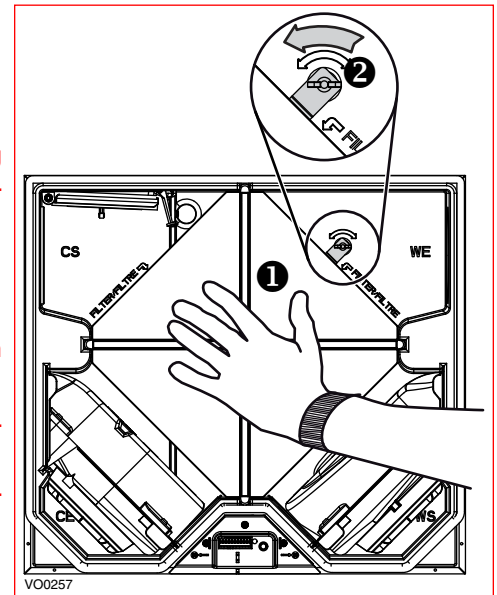

3. MAINTENANCE (CONT'D)

3.1 QUARTERLY MAINTENANCE (CONT'D)

7. Reinstall the filters on the cleaned core; refer to the core label for proper location.

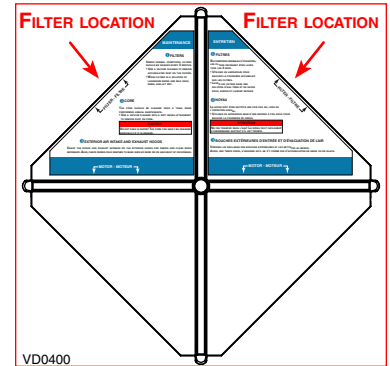

8. Slide the cleaned core with filters in the unit. Refer to filters location indicators embossed inside the unit to position adequately the core. Use the core bracket to lock the core in place.

⚠ WARNING
Hold the core until the core bracket is completely tighten.

9. Close the door, plug back the unit and turn it on.

NOTE: The unit will return to its previous setting after a 30-second delay for booting sequence.

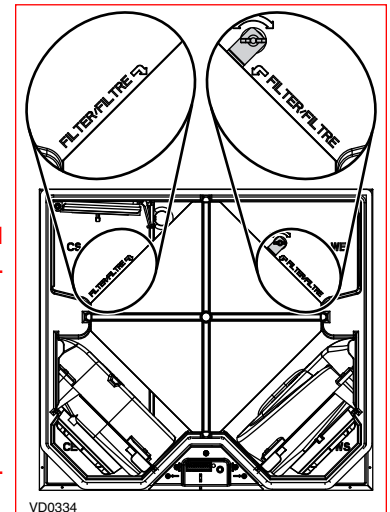

3.2 ANNUAL MAINTENANCE

Proceed as the Quarterly Maintenance (Section 3.1), but before reinstalling the cleaned core, clean the supply side damper using a vacuum cleaner and a soft brush attachment. Check if it can move freely. Then, clean the exterior hoods.

4. TROUBLESHOOTING

If the unit does not work properly:

ERV100SP unit: Turn off the unit using its main control, reset the unit by unplugging it for one minute and then replug it.

ERV100S unit: Turn off the unit using the integrated push-button, reset the unit by unplugging it for one minute and then replug it.

All units: If it still not working properly, refer to table below.

PROBLEMS		TRY THIS
1.	Nothing works.	<ul style="list-style-type: none"> See if the unit is plugged in. See if the unit is receiving power from the house circuit breaker or fuse.
2.	Condensation on windows (air too humid).	<ul style="list-style-type: none"> Operate the unit on maximum speed ventilation until the situation is corrected. Leave curtains half-open to allow air circulation. Store all firewood in a closed room with a dehumidifier or in a well ventilated room, or store the wood outdoors. Do not adjust the thermostat of your heating system below 64°F.
3.	Inside air too dry.	<ul style="list-style-type: none"> Temporarily use a humidifier. Operate the unit in recirculation mode (if available).
4.	Air too cold at the air supply grille.	<ul style="list-style-type: none"> Check if the exterior hood(s) is (are) not blocked. Operate the unit in low speed ventilation or in intermittent or recirculation mode (if available). Install a duct heater.
5.	A. The LED of the integrated control is blinking RED (one blink every second).	<ul style="list-style-type: none"> There is a problem with one of the motors. The unit is OFF. Contact your installer.
	B. The LED of the integrated control is blinking RED (2 blinks per second, faster blink.)	<ul style="list-style-type: none"> When outdoor temperature is colder than -13°F, it could be normal for the unit to enter in Protection Mode. Unit exhaust air without entering fresh air for a 2-hour period, then resume to its previous operation mode and stops flashing RED. If LED continues to flash RED when back to previous mode, contact your installer.
6.	A. The LED of the integrated control is blinking GREEN (2 blinks every 2 seconds).	<ul style="list-style-type: none"> There is a problem with the cold side thermistor. The unit is still working, but will defrost frequently. Contact your installer.
	B. The LED of the integrated control is blinking GREEN (2 blinks per second, faster blink).	<ul style="list-style-type: none"> There is a problem with the warm side thermistor. The unit is OFF. Contact your installer.
7.	The LED of the integrated control is blinking AMBER (ERV100SP unit only).	<ul style="list-style-type: none"> There is a problem with the damper system. Contact your installer.
8.	The push button on integrated control or integrated defrost control does not work.	<ul style="list-style-type: none"> The 30-second boot sequence is not completed. According to the unit, see 2.1 or 2.2 on page 4. If the booting sequence is completed and the push button still doesn't work, contact your installer.

For wall controls problems, refer to the Troubleshooting section in the *Main and auxiliary wall controls user guide* (included with the ventilation unit and also available at www.broan.com).

If the problem is still not solved, contact your installer.