



BROAN ERV140 ECM

Part no. ERV140TE

85 to 140 CFM*

40 to 125 CFM*

65 to 140 CFM*

40 to 80 CFM*

55 to 125 CFM* (Factory Set)

*Maximum speed at 0.4 in. w.g.



VB0239

A NEW ERA BEGINS WITH THE ERV140 ECM ULTRA-EFFICIENT AND ENVIRONMENTALLY- FRIENDLY ENERGY RECOVERY VENTILATOR

The ERV140 ECM has been designed to be one of the most energy-efficient ERV air exchangers available on the market. Its innovative design incorporates high performance ECM* motors which consume significantly less electricity. ERVs are ideal for LEED®-certified residential projects and other energy-efficient homes because they recover the heat or coolness of the indoor air while helping to maintain comfortable moisture levels inside the home.

- Perfect for drier homes using humidifiers in heating season and air conditioning during cooling season
- Compact footprint allows an easy fit in restricted spaces
- No drain required**
- State-of-the-art ECM motors provide significant electrical consumption savings
- 6" metal ports located on top of unit to simplify installation and provide a cleaner appearance
- Integrated pressure taps and balancing dampers to quickly measure and balance the air-flow
- Faster and easier installation of insulated flexible ducts with practical straps
- Homeshield™ defrosting system (no negative pressure)
- ENERGY STAR® qualified: Ideal for high performance small to mid-size homes

*Electronically Commutated Motor.

**For most climate zones.

REPAIRS AND MAINTENANCE

The ERV140 ECM high output ECM* motors are permanently lubricated. The electronic circuit board eliminates electromechanical parts, reducing repair time to a minimum.

WARRANTY

The ERV140 ECM unit is protected by a 5-year warranty on all parts, including the energy recovery core, with the original proof of purchase.

Available at:

¹This product earned the ENERGY STAR® by meeting strict energy efficiency guidelines set by Natural Resources Canada and the EPA. It meets ENERGY STAR® requirements only when used in Canada.

ENERGY RECOVERY VENTILATOR

Controls

- This unit is very simple to operate. Once it is installed, press on its push button, located under the unit, to activate it. Press once for low speed, once again for high speed, and once more to stop it.
- For more convenience, this unit can also be controlled by an optional main control. For a complete list of optional main and auxiliary controls available, refer to the **Wall Control Compatibility Chart** on last pages of wall controls specification sheet, available at www.broan.com
- For more details about controls, refer to the **Main and auxiliary wall controls** user guide, also available at www.broan.com

Option

- Complete line of registers and diffusers

Homeshield™ Defrosting System

The ERV140 ECM uses a unique defrosting method. No negative pressure is created by air exhausted to the outside, as the air is recirculated into the house, helping to prevent any backdraft.

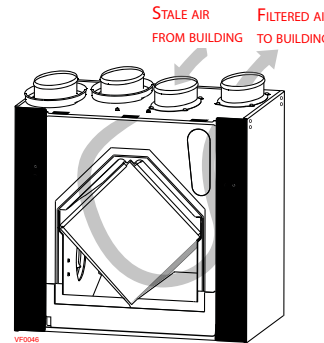

OUTSIDE TEMPERATURE °F	DEFROST CYCLE MIN./OPERATING MIN.
WARMER THAN 23	No DEFROST
23 TO 5	7/40
5 TO -17	7/25
-17 AND LESS	10/22

Energy Recovery Core

Dimensions: 10" x 10" x 14.25"

Exchange surface: 110 ft.²

Weight: 20 lb.

Material: Polymerized paper

Type: Cross Flow

Warranty: 5-year

Requirements and standards

- Complies with the UL 1812 requirements regulating the installation of Energy Recovery Ventilators
- Complies with the CSA C22.2 no. 113 Standard applicable to ventilators
- Complies with CSA C444 requirements regulating the installation of Energy Recovery Ventilators
- Technical data was obtained from published results of tests relating to CSA C439 Standards
- HVI certified and ENERGY STAR® qualified¹

DIMENSIONS: ERV140 ECM

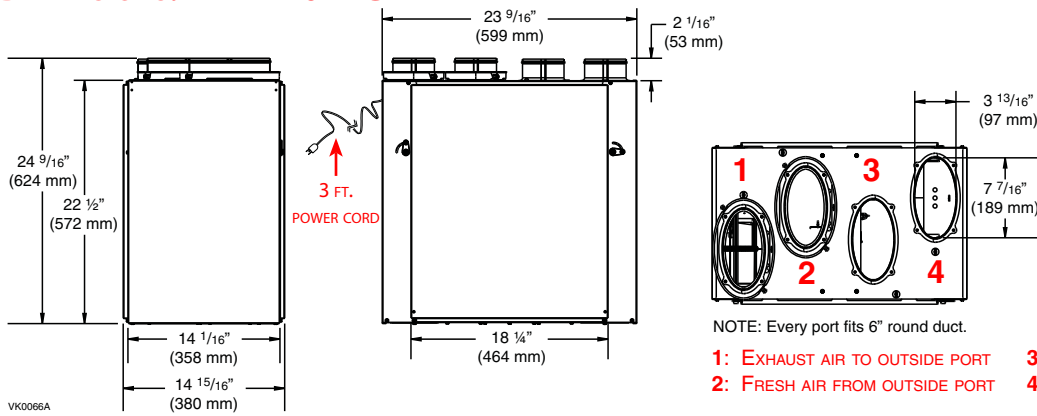

NOTE: ALL UNITS PORTS WERE CREATED TO BE CONNECTED TO DUCTS HAVING A MINIMUM OF 6" DIAMETER, BUT IF NEED BE, THEY CAN BE CONNECTED TO BIGGER SIZED DUCTS BY USING AN APPROPRIATE TRANSITION (E.G.: 6" DIAMETER TO 7" DIAMETER TRANSITION).

NOTE: Every port fits 6" round duct.

- 1:** EXHAUST AIR TO OUTSIDE PORT **3:** EXHAUST AIR FROM BUILDING PORT
2: FRESH AIR FROM OUTSIDE PORT **4:** FRESH AIR TO BUILDING PORT

VENTILATION PERFORMANCE

EXTERNAL STATIC PRESSURE		NET SUPPLY AIR FLOW		GROSS AIR FLOW			
PA	IN. W.G.	L/S	CFM	SUPPLY		EXHAUST	
				L/S	CFM	L/S	CFM
25	0.1	76	161	77	163	78	166
50	0.2	74	157	75	158	74	156
75	0.3	69	147	70	149	71	150
100	0.4	66	140	67	142	65	138
125	0.5	59	125	60	127	62	132
150	0.6	55	117	56	119	58	122
175	0.7	50	105	50	107	53	111
200	0.8	44	93	45	95	45	95
225	0.9	37	77	37	79	39	83
250	1.0	29	61	29	62	34	73

FAN CURVES ACCORDING TO SPEED

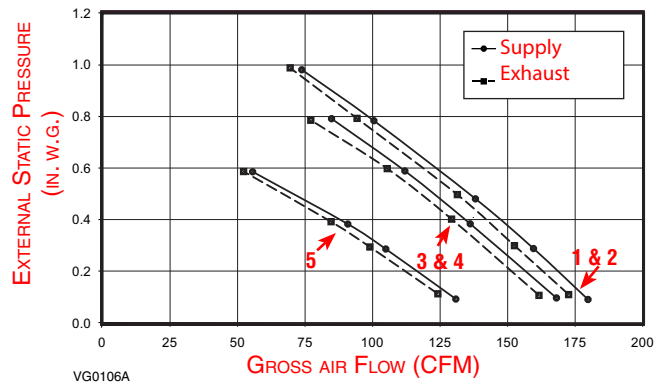

ENERGY PERFORMANCE

SUPPLY TEMPERATURE	NET AIR FLOW		POWER CONSUMED	SENSIBLE RECOVERY EFFICIENCY	APPARENT SENSIBLE EFFECTIVENESS	LATENT RECOVERY/MOISTURE TRANSFER
	°F	L/S				
HEATING						
32	24	52	24	67	73	0.59
32	31	65	30	67	72	0.55
32	39	83	36	65	71	0.52
32	57	122	60	62	67	0.46
-13	33	70	39	60	75	0.61
95	24	51	24	52**	71	0.51

- SPEED RANGE 1: 85 TO 140 CFM*
- SPEED RANGE 2: 65 TO 140 CFM*
- SPEED RANGE 3: 55 TO 125 CFM* (**FACTORY SET**)
- SPEED RANGE 4: 40 TO 125 CFM*
- SPEED RANGE 5: 40 TO 80 CFM*

*MAXIMUM SPEED AT 0.4 IN. W.G.

**Total recovery efficiency

NOTE: All specifications are subject to change without notice.

SPECIFICATIONS

- Model: ERV140 ECM
- Part Number: ERV140TE
- Total Assembled Weight (including polymerized paper core): 65 lb.
- Oval shaped ports; fit 6" round ducts
- Drains: Optional
- Core Filters: 2 washable Merv 7 filters, 9.2" x 14.25" x 0.38"
- Housing: Pre-painted steel

- Insulation: Expanded polystyrene
- Mounting: Suspension by chains and springs
- Supply and Exhaust Blower Motors: 2 ECM motors
 - Protection type: Thermally protected
 - Insulation class: B
- Speed Control on Unit:
 - Low speed and high speed
 - Other modes available with VT8W or VT7W

- Energy Recovery Core:
 - Energy Exchange Surface Area: 110 ft.²
 - Type: Crossflow
 - Material: Polymerized paper
- Unit Electrical Characteristics:

Volts	Frequency	Amps	Watts
120	60 Hz	1.3	90

Project:	REMARKS
Location:	
Part no.:	
Qty.:	
Submitted by:	Date:

BROAN



Broan-NuTone LLC, 926 West State Street, Hartford, WI 53027 (1-877-862-7626)

www.broan.com

ERV140ECMd160531