

Specification Submittal Data / Panasonic Ventilation Fan

Description:

Ventilating fan shall be Low Noise ceiling mount type rated for continuous run. Fan shall be ENERGY STAR® rated and certified by the Home Ventilation Institute (HVI). Evaluated by Underwriters Laboratories and conform to both UL and cUL safety standards.

Motor/Blower:

- Four-pole totally enclosed condenser motor rated for continuous run.
- Unique Veri-Boost™ integral switch provides a 20 CFM boost, when needed.
- Power Rating shall be 120 volts and 60 Hz.
- Fan shall be UL and cUL listed for tub/shower enclosure when used with a GFCI protected circuit and used in insulated ceiling (TYPE I.C)
- Motor equipped with thermal cutoff fuse.
- Removable with permanently lubricated plug-in motor.

Housing:

- Galvanized steel body.
- Small, 4-3/4" housing depth
- 4" round diameter duct.
- Built in backdraft damper.
- Built-in metal flange provides blocking for penetrations through drywall as an Air Barrier, and assists with the decrease in leakage in the Building Envelope during blower door testing.
- Simply mounts directly to the joist using 4 screws between top and side panels.

Grille:

- Small, attractive design using PP material.
- Attaches directly to housing with torsion springs.

Warranty:

- ALL Parts: For period of 3 years from the date of the original purchase.

Architectural Specifications:

Ventilation fan shall be ceiling mount, ENERGY STAR rated, with no less than 70 CFM and no more than 1.1 sone as certified by the Home Ventilating Institute (HVI) at 0.1 static pressure in inches water gauge (w.g.) with no less than 56 CFM and no more than 1.4 sone as certified by HVI at 0.25 w.g. Power Consumption shall be no greater than 20 watts at 0.1 w.g. and at 0.25 w.g. ENERGY STAR rated with efficiency of no less than 3.5 CFM/watt at 0.1 w.g. and 2.8 CFM/watt at 0.25 w.g. The motor shall be totally enclosed, four pole condenser type engineered to run continuously. Built-in Veri-Boost™ integral switch provides a 20 CFM boost, when needed, for a maximum performance level of 90CFM. This feature helps ensure the fan meets designed airflow requirements and provides Ventilation Verification Assurance: ≥ 50 CFM Installed Performance. Power rating shall be 120v/60Hz. Duct diameter shall be no less than 4". Fan shall be UL and cUL listed for ceiling installation and tub/shower enclosure when used with a GFCI protected circuit. Fan can be used to comply with ASHRAE 62.2, LEED, ENERGY STAR, IAP, EarthCraft, California Title-24 and WA Ventilation Code.

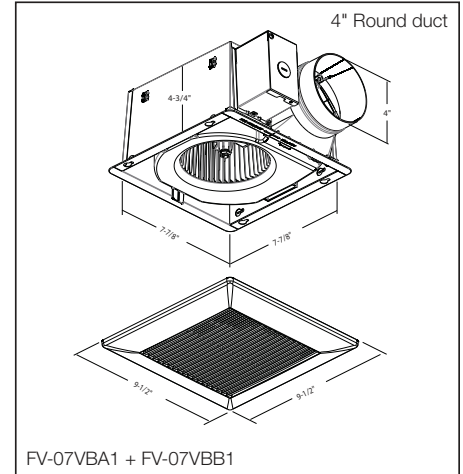

Universal Can (U-Can) Contractor Packs:

EcoVent™ is offered in contractor packs, whereby the housing and motor/grille assembly are packaged separately. This allows contractors to store the components separately without fear of parts getting lost or damaged on site.

| EcoVent™ U-Can Contractor Packs* | | | |
|----------------------------------|-----------------------|--|---------------|
| Model # | Description | Contents | Master Pack * |
| FV-07VBA1 | Universal Housing Can | Housing Can, Duct Adaptor & Junction Box | 4 |
| FV-07VBB1 | Motor/Grille Assembly | Motor & Grille | 4 |

* Must order in quantities of 4, shipment will contain 1 box with 4 pieces of each item. HVI & ENERGY STAR require a single model number for listing, so EcoVent™ can be found under FV-07VBA1 in both directories.

Performance Curve 4" Round duct

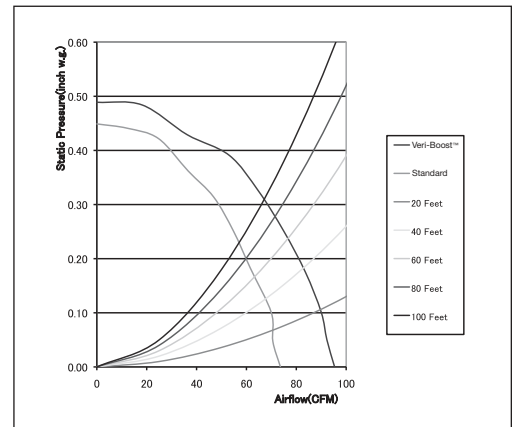

| Fan Specifications | EcoVent™: FV-07VBA1 + FV-07VBB1 | | | |
|--------------------------------|---------------------------------|------|-----------------------|------|
| | Standard Setting | | Veri-Boost™ Activated | |
| Fan Speed (Veri-Boost) | | | | |
| Static Pressure in inches w.g. | 0.1 | 0.25 | 0.1 | 0.25 |
| Air Volume (CFM) | 70 | 56 | 90 | 75 |
| Noise (sones) | 1.1 | 1.4 | 1.5 | 2.0 |
| Power Consumption (watts) | 20.0 | 20.0 | 24.0 | 24.0 |
| Energy Efficiency (CFM/Watt) | 3.5 | 2.8 | 3.8 | 3.1 |
| Speed (RPM) | 907 | 1200 | 1019 | 1266 |
| Current (amps) | 0.15 | 0.14 | 0.19 | 0.18 |
| MAX. Current (amps) | 0.25 | | | |
| Power Rating (V/Hz) | 120/60 | | | |
| ENERGY STAR rated | Yes | | | |

0.25=Installed Performance

For complete Installation Instructions visit us.panasonic.com/ventfans

| Model | Quantity | Comments | Project: |
|-------|----------|----------|---------------|
| | | | Location: |
| | | | Architect: |
| | | | Engineer: |
| | | | Contractor: |
| | | | Submitted by: |
| | | | Date: |

Panasonic Eco Solutions North America
Eco Products Division
 Two Riverfront Plaza
 Newark, NJ 07102

us.panasonic.com/ventfans

