

GHOST

GH-08

WHOLE HOUSE VENTILATOR

PRODUCT MANUAL & INSTALLATION GUIDE

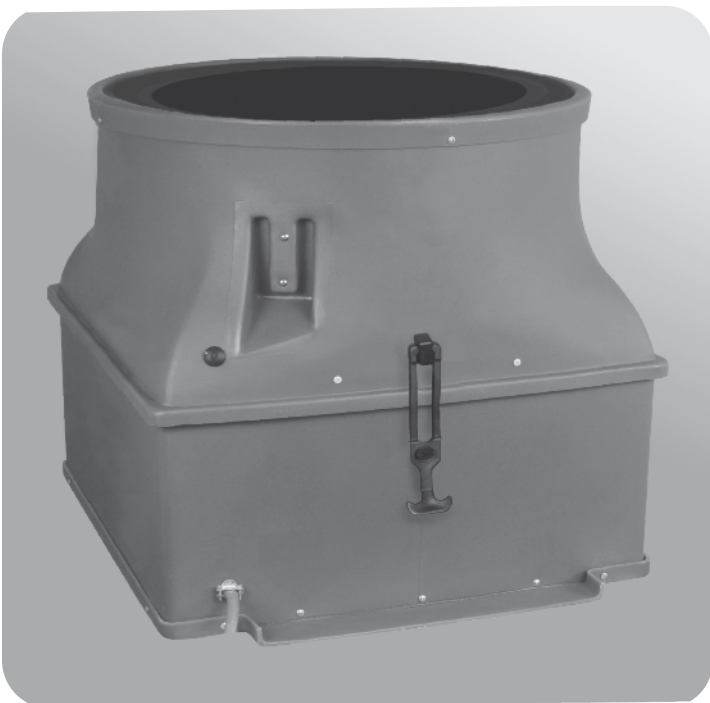

Serial Number _____

Date of Purchase _____

Point of Purchase _____

The serial number is located on the shipping carton and on a label affixed to an insulated door.

Unpacking your GHOST:

When you have unpacked your GHOST carefully you will find the following:

- One (1) GHOST
- One (1) White Metal Grille w/(6) Screws
- One (1) Hand Held Remote Transmitter
- One (1) Remote Receiver w/ line cord & interconnect cable

The Best Location for your GHOST: The GHOST should be installed in your attic in a central location within your home. Above a central hallway or at the top of a stairwell will provide the best airflow.

- ▶ Make sure that there aren't any pipes, wires, rafters or air conditioning or heating ducts running through the space where the GHOST will be installed. The GHOST can NOT be mounted vertically.
- ▶ Make sure that you have adequate exhaust area out of your attic. This can be accomplished with a combination of roof, ridge or gable end vents. The GHOST requires a minimum of 9 square feet of attic exhaust area.
- ▶ If your home has an engineered roofing system, care should be taken that the GHOST will fit within the truss layout.

READ AND SAVE THESE INSTRUCTIONS

WARNING: TO REDUCE THE RISK OF FIRE, ELECTRIC SHOCK, OR INJURY TO PERSONS, OBSERVE THE FOLLOWING:

- ✓ Use this unit in the manner intended by the manufacturer. If you have any questions, contact the manufacturer.
- ✓ Before servicing or cleaning unit, switch power off at service panel and lock service panel to prevent power from being switched on accidentally. When the service disconnecting cannot be locked, securely fasten a prominent warning device, such as a tag, to the service panel.
- ✓ When cutting or drilling into wall or ceiling, do not damage electrical wiring or other hidden utilities.
- ✓ Never place a switch where it can be reached from a tub or shower.
- ✓ Do not use this fan over a tub or shower.
- ✓ Do not use this fan over cooking appliances.

✓ **WARNING:** To Reduce The Risk of Fire or Electric Shock, Do Not Use This Fan With Any Solid-State Speed Control Device.

CAUTION: For General Ventilation Use Only. Do Not Use To Exhaust Hazardous Or Explosive Materials And Vapors

CAUTION: This unit has an unguarded impeller. Do Not Use in Locations Readily Accessible to People or Animals.

LIKE US ON
FACEBOOK



FOLLOW US
ON TWITTER



320 Main Street • Buzzards Bay, MA 02532
508-759-4660 / 800-222-5932 / Fax 508-759-6001

Installation

Tools and supplies needed:

You will need the following items: two pieces of 2x stock to match your existing framing, a saw to cut the hole in the ceiling, a hammer or screw gun to attach the blocking to the existing joists, a Phillips head screw driver to attach the grille, weather strip material and low expansion spray foam sealant.

1. The fan housing will fit either 16" or 24" on center framing. Cut two pieces of 2x stock (2 x 6 or 2 x 8 etc.) of the same dimension as the existing joists. Add these pieces of framing to form a box between the joists (Figure 1).

TIP: When the GHOST is to be installed in a hallway or other location with low ceilings, some homeowners find that building a box out of 2 x 10s or similar material will raise the GHOST to a position where the sound level will be reduced but the efficiency of the fans will not be diminished. This box should not exceed 24 inches in height.

2. Cut a hole in the ceiling under where the GHOST will be installed. The hole should be no larger than **14 1/2" x 22 1/2"**. This will allow for the grille to cover the exposed edges. The suggested method for making the proper sized hole in the ceiling is; cut a pilot hole under where the fan will be installed (Figure 2). From above, using a saw, cut along the inside edge of the framework removing the ceiling panel and any strapping within the framework. **Do not damage electrical wiring or other hidden utilities.**

3. Install a foam weather stripping or other flexible material (not supplied) on the top of the joists and added framing. This will serve to seal between the housing and the framing as well as dampen vibrations. Check the joint between the ceiling and the 2x stock. Some types of ceilings are spaced away from the joists. Any gap between the 2x's and the ceiling should be sealed prior to final installation. (Figure 3) Use a low expansion spray foam sealant (not supplied).

4. Set the GHOST lower housing onto the framing. The lower housing will fit into the box with the mounting flanges overlapping the framing. **DO NOT DRAG THE GHOST INTO POSITION AS THIS MAY SEVERELY DAMAGE IT.**

5. Set the GHOST upper housing at an angle on top of the lower housing, orienting the upper housing so that the fan motor connections are located in the same corner (Figure 4). Push the fan electrical connection into the fan electrical feed. The connectors are 'keyed' so they will only connect correctly (Figure 5).

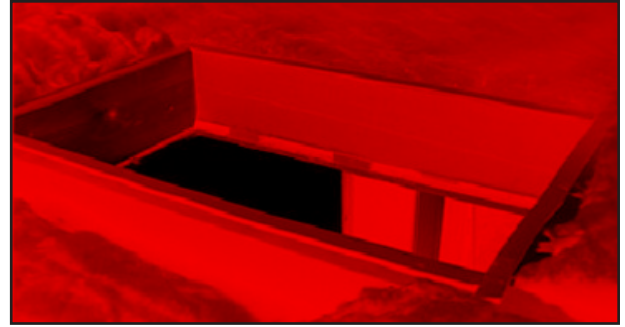

Figure 1.



Figure 2.

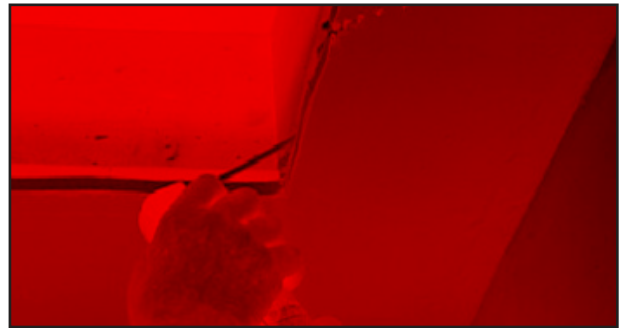

Figure 3.

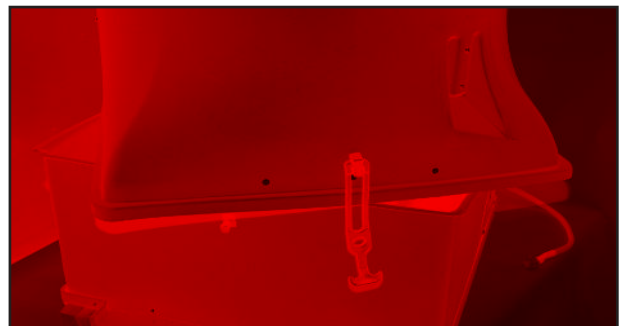

Figure 4.

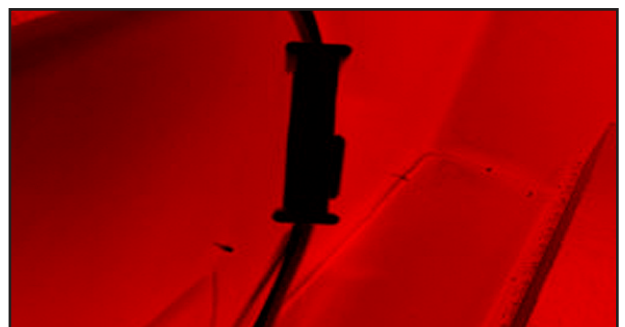

Figure 5.

6. Rotate the upper housing until it lines up with the lower housing. Make sure the edges of the two housings mate all the way around the GHOST (Figure 6) and then pull the black attachment handles down over their attachment posts (Figure 7).

7. If desired, secure the GHOST to the top of the joists.

8. Plug the connector from the GHOST into the Control Box. Plug the Control Box into an unswitched, grounded receptacle.

9. Install the ceiling grille (screws provided).

10. Check the unit for proper operation.

Operating your GHOST

Important - Be sure at least one window is open when the fan is operating. The GHOST is controlled by the hand held remote transmitter. The transmitter has two buttons; ON/OFF and LO/HI. LO/HI controls the speed of the fan. See the Wiring section of this manual for further details.

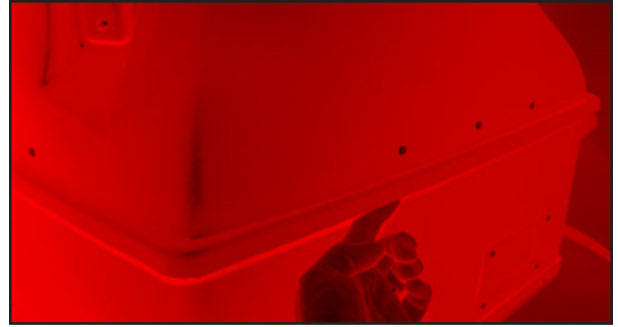

Figure 6.

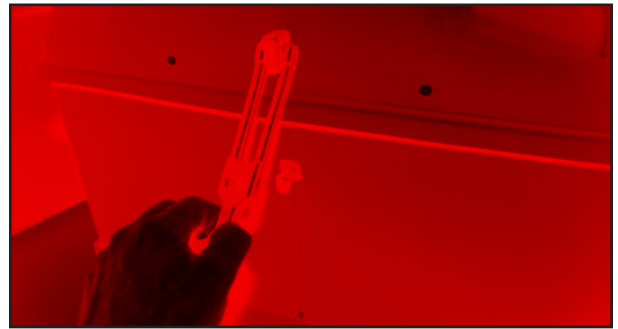
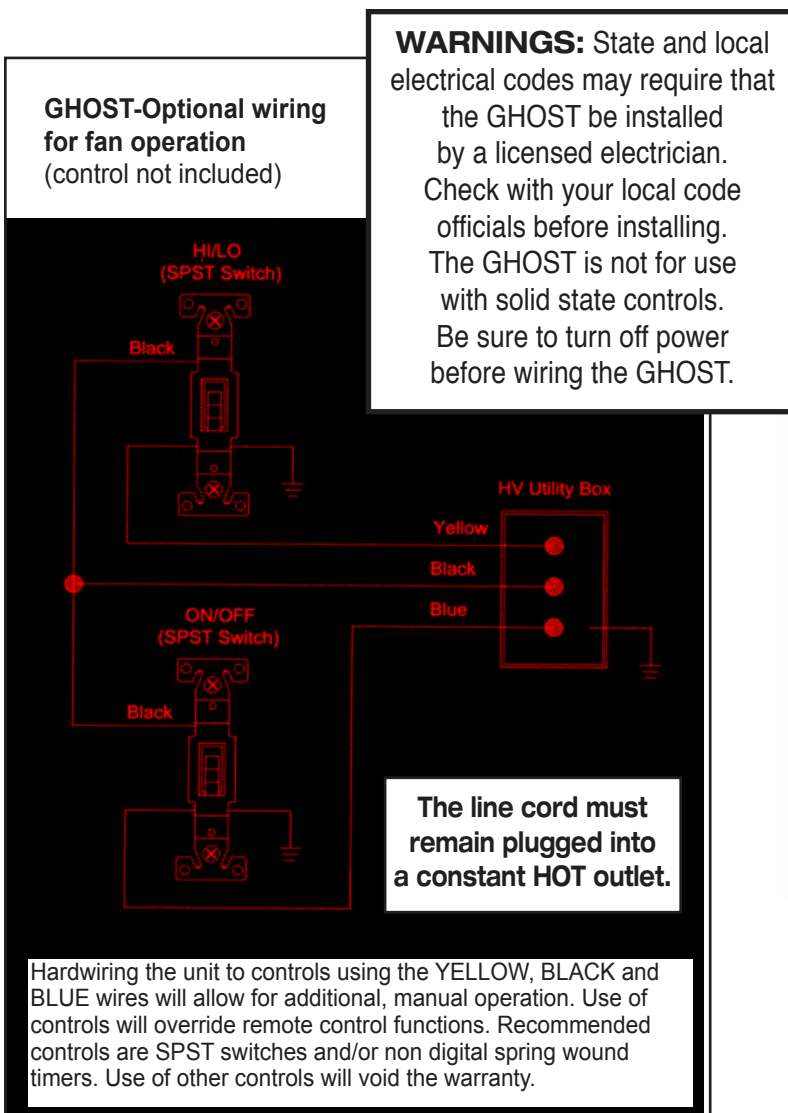

Figure 7.



SPECIFICATIONS

Electrical:	
Voltage	115 VAC 60Hz
Power	(High Speed) 450 Watts (Low Speed) 340 Watts
Air Flow	High Speed 3400 CFM Low Speed 1900 CFM
Operation	30 second Door Cycle Time (Open-Close)
Insulation Value of Closed Doors	Model:Ghost R-38 Model:Ghost/R50 R-50
Weights	Whole House Ventilator: 48 Lbs. Shipping: 71 Lbs. (2 boxes)
Top Housing	26 1/4" L x 26" W x 14 1/8" H
Lower Housing	25 7/8" L x 29 1/2" W x 13 5/8" H

GHOST

WHOLE HOUSE VENTILATOR PRODUCT MANUAL & INSTALLATION GUIDE

Troubleshooting

If the wireless remote fails to activate the fan try the following:

- The battery may need replacing. The transmitter uses a type CR2016 battery. Remove the back plate from the transmitter and remove the battery. Following the markings, replace the battery and secure the back plate to the transmitter.
- Check that all the connections are tight and that there is power to the outlet.
- If wall switches are also used to control the Ghost, check to see that they are not in use and overriding the hand held transmitter.

If the doors are open but the fan is not rotating try the following:

- Check the electrical connection between the upper and lower sections.
- Turn off the power and check for foreign matter blocking fan rotation.

LIMITED WARRANTY If, within the period of three years from the date of purchase, the GHOST (the Product) is defective or malfunctions in normal home use, Tamarack Technologies, Inc. will repair or replace the Product, at its discretion. Customer is responsible for shipping charges.

NOTE: Some states codes require fans to be hardwired. HARDWIRING THE GHOST WILL NOT VOID WARRANTY PROVIDING THE WIRING IS PERFORMED BY A LICENSED ELECTRICIAN.

CONDITIONS, EXCLUSIONS, AND LIMITATIONS -This Warranty is subject to the following conditions, exclusions and limitations: THIS WARRANTY DOES NOT COVER PROBLEMS RESULTING FROM INSTALLATION, OPERATION OR MAINTENANCE THAT HAS BEEN UNDERTAKEN OTHER THAN IN ACCORDANCE WITH THE INSTRUCTIONS. THIS WARRANTY DOES NOT COVER PROBLEMS RESULTING FROM DEFECTS IN OR CAUSED BY ASSOCIATED EQUIPMENT (FURNACES, SOLARIA, ETC.); FROM REPAIRS OR MODIFICATIONS ATTEMPTED BY PERSONS OTHER THAN TAMARACK TECHNOLOGIES, INC.; FROM ABUSE, ACCIDENTAL OR SHIPPING DAMAGE OR ACTS OF GOD. THIS WARRANTY DOES NOT APPLY TO THE PRODUCT USED OUTSIDE THE UNITED STATES, ITS TERRITORIAL POSSESSIONS, AND CANADA. EXCEPT AS SET FORTH ABOVE, NO EXPRESS OR IMPLIED WARRANTY IS GIVEN OR AUTHORIZED BY TAMARACK TECHNOLOGIES, INC. AND ALL OTHER SUCH WARRANTIES ARE EXPRESSLY DISCLAIMED. ANY WARRANTY OR MERCHANTABILITY OF FITNESS FOR ANY PARTICULAR PURPOSE SHALL BE LIMITED TO THE WARRANTY HEREUNDER. MOREOVER, ANY LIABILITY OF TAMARACK TECHNOLOGIES, INC. FOR THE PRODUCT SHALL BE LIMITED TO THE REPLACEMENT VALUE OF THE PRODUCT. IN NO EVENT SHALL TAMARACK TECHNOLOGIES, INC. BE LIABLE FOR ANY INCIDENTAL DAMAGES OR FOR ANY CONSEQUENTIAL PROPERTY OR COMMERCIAL DAMAGES, IRRESPECTIVE OF THE CAUSE THEREOF, OCCURRING EITHER DURING OR AFTER THE WARRANTY PERIOD, INCLUDING WITHOUT LIMITATION ANY DAMAGES TO ANY PART OF A BUILDING OR ITS CONTENTS. NOTE: SOME STATES DO NOT ALLOW THE EXCLUSION OR LIMITATION OF INCIDENTAL OR CONSEQUENTIAL DAMAGES AND SOME STATES DO NOT ALLOW LIMITATIONS ON HOW LONG AN IMPLIED WARRANTY LASTS, SO THE ABOVE LIMITATIONS OR EXCLUSIONS MAY NOT APPLY TO YOU. THIS WARRANTY GIVES YOU SPECIFIC LEGAL RIGHTS AND YOU MAY ALSO HAVE OTHER RIGHTS THAT VARY FROM STATE TO STATE. **PROOF OF PURCHASE REQUIRED.**



320 Main Street • Buzzards Bay, Ma 02532
508-759-4660 / 800-222-5932 / Fax 508-759-6001