

# Uponor

RADIANT HEATING AND  
COOLING SYSTEMS

**ENGINEERED POLYMER  
(EP) HEATING MANIFOLD**

**INSTALLATION GUIDE**



EP Heating Manifold  
Installation Guide

## **EP Heating Manifold Installation Guide**

Published by Uponor North America

5925 148th Street West

Apple Valley, MN 55124 USA

Phone: 800.321.4739

Fax: 952.891.2008

[www.uponorpro.com](http://www.uponorpro.com)

© 2013 Uponor North America

All Rights Reserved.

Third Edition August 2013

First Printing November 2008

Printed in the United States of America

# Table of Contents

<b>Section 1: General Recommendations.</b>	<b>1</b>
Important Notes	1
Symbols Used in this Manual	1
Designated Application	2
<b>Section 2: EP Heating Manifold Overview</b>	<b>3</b>
Preparation Before Installation.	4
Tools Required	4
<b>Section 3: EP Heating Manifold Connection Options.</b>	<b>5</b>
<b>Section 4: EP Heating Manifold Mounting Instructions</b>	<b>7</b>
Mounting Manifold to a Wall or Cabinet	7
<b>Section 5: Installing Manifold Accessories</b>	<b>9</b>
Installing Temperature Gauge	9
Installing the Elbow Kit	9
Mounting Additional Manifold Outlets.	11
<b>Section 6: Connecting Tubing to the Manifold</b>	<b>12</b>
<b>Section 7: Filling and Purging the Manifold</b>	<b>15</b>
<b>Section 8: Pressure Testing</b>	<b>17</b>
<b>Section 9: Adjusting Manifold Valves.</b>	<b>18</b>
<b>Section 10: Manifold Maintenance</b>	<b>19</b>
<b>Section 11: Technical Data.</b>	<b>20</b>
Chemicals.	21
<b>Section 12: Manifold Balancing Form.</b>	<b>22</b>



## Section 1

# General Recommendations

### Important Notes

- Read and follow the instructions in this guide.
- A qualified person must install this product according to local code.
- It is prohibited to make changes or modifications not specified in this guide.
- Uponor North America is not responsible for damages or injuries that may result from not following the instructions in this guide.
- Do not use ethylene glycol with the EP Heating Manifold. Only use propylene glycol.

### Symbols Used in this Manual



**Warning:** Risk of bodily injuries. Nonobservance may harm health or cause damage to product components.



**Caution:** Important note on functionality.



**Information:** Important advice and information



See another document.



See another page in the guide.



Required tools



Check that everything is okay.



Temperature



Time



Operating Pressure

## Designated Application

The EP Heating Manifold distributes water through the radiant floor heating/cooling system. Typically it is installed on the wall or in a manifold cabinet (surface or concealed installation).



Contact Uponor before modifying the EP Heating Manifold. Uponor is not liable for damage resulting from misuse.

## Section 2

# EP Heating Manifold Overview

Featuring two to eight loops, the Uponor Engineered Polymer (EP) Heating Manifold comes fully assembled with flow meters and R32 union connections. The valve body with the preassembled flow meters is the supply manifold. The valve body without the flow meters is the return manifold. The return manifold is where the actuators (if used) will mount. Additionally, the modular offering includes a single outlet for add-on flexibility. Ideal for sustainable installations, the EP Heating Manifold tolerates high pressure at lower temperatures.

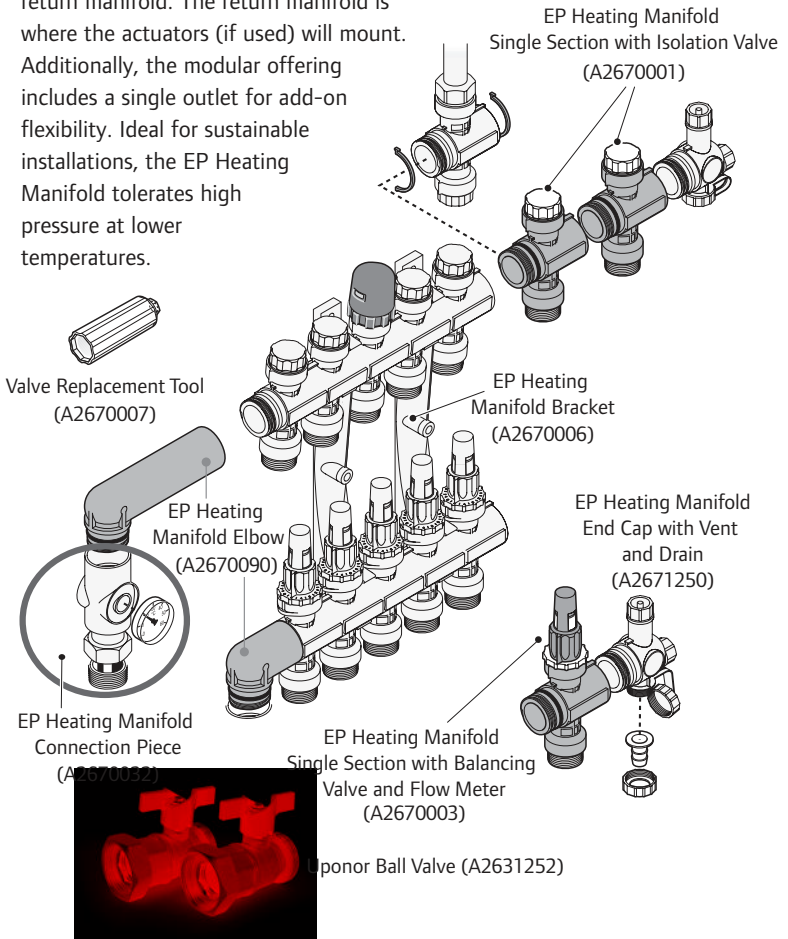

## Preparation Before Installation

Verify product contents.

**Note:** Manifold fittings are sold separately. Use ProPEX® or QS-style fittings. Refer to the Uponor Product Catalog for more information.



### Tools Required

- Tubing cutter
- Wrench
- Level
- Flat screwdriver
- Electric drill
- Pressure testing equipment
- Valve replacement tool
- ProPEX Expansion Tool



### Section 3

# EP Heating Manifold Connection Options

See **Figures 3-1** and **3-2** for connection options.

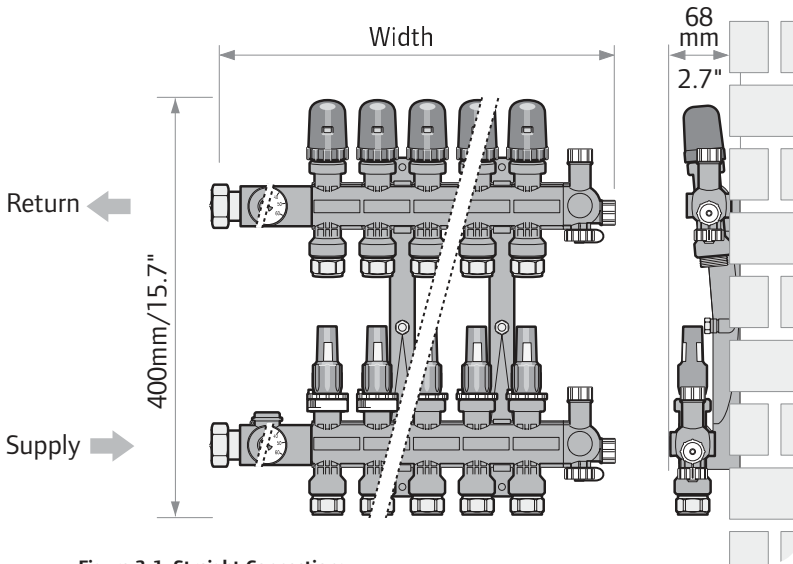

**Figure 3-1: Straight Connections**

Number of Loops	Part No.	Width
2	A2670201	9.6" (245mm)
3	A2670301	11.6" (295mm)
4	A2670401	13.6" (345mm)
5	A2670501	15.6" (395mm)
6	A2670601	17.6" (445mm)
7	A2670701	19.5" (495mm)
8	A2670801	21.5" (545mm)

**Table 3-1: Manifold Widths**

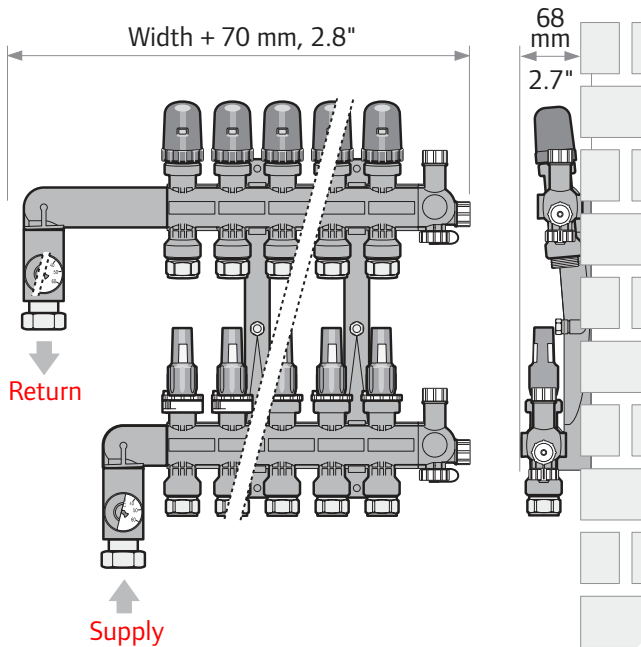

Figure 3-2: Angle Connections

Number of Loops	Part No.	Width
9	A2670801 + A2670001 A2670003	23.5" (595mm)
10	A2670801 + 2 x A2670001 2 x A2670003	25.5" (645mm)
11	A2670801 + 3 x A2670001 3 x A2670003	27.5" (695mm)
12	A2670801 + 4 x A2670001 4 x A2670003	29.5" (745mm)

Table 3-2: Manifold Widths

## Section 4

# EP Heating Manifold Mounting Instructions

### Mounting Manifold to a Wall or Cabinet

1. Mount the bracket to the wall or in a cabinet. See **Table 4-1** on **page 8** for proper spacing of the bracket bars.
2. Snap the manifold into the bracket. Make sure the manifold locks into position. Listen for the click.

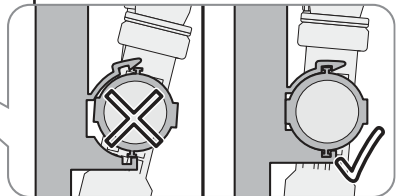
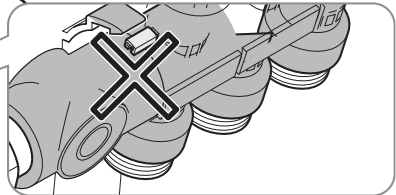
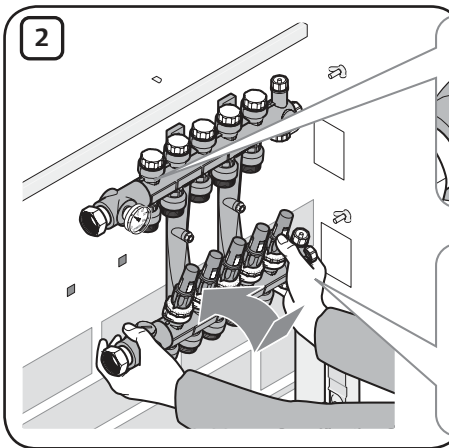
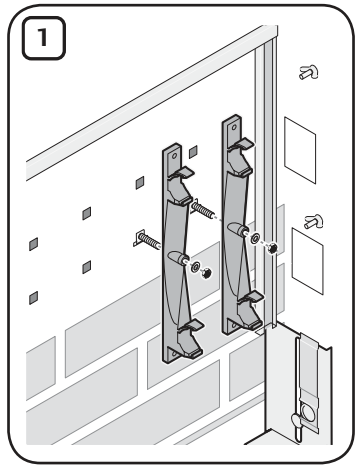

Number of Loops	A inch (mm)	B inch (mm)	C inch (mm)
2	5.3 (135)	2 (50)	2.6 (65)
3	5.3 (135)	3.9 (100)	2.6 (65)
4	5.3 (135)	5.9 (150)	4.5 (115)
5	5.3 (135)	5.9 (150)	4.5 (115)
6	5.3 (135)	7.9 (200)	4.5 (115)
7	5.3 (135)	7.9 (200)	6.5 (165)
8	7.3 (185)	7.9 (200)	6.5 (165)
9	7.3 (185)	9.8 (250)	6.5 (165)
10	7.3 (185)	11.8 (300)	6.5 (165)
11	7.3 (185)	11.8 (300)	8.5 (215)
12	9.3 (235)	15.7 (400)	8.5 (215)

Table 4-1: Bracket Spacing

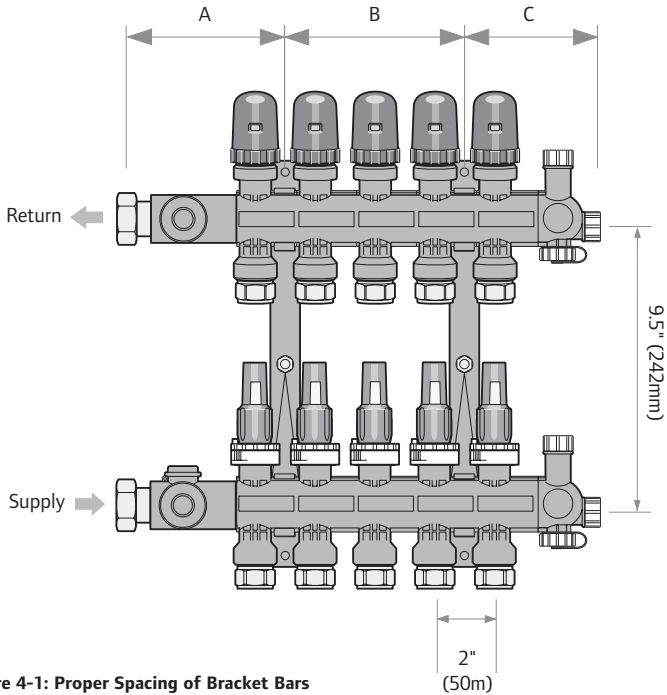

Figure 4-1: Proper Spacing of Bracket Bars

## Section 5

# Installing Manifold Accessories



**Note:** Thread tape or similar thread sealants are not necessary for assembling the manifold accessories.

### Installing Temperature Gauge

When installing the temperature gauge into the manifold connections, ensure they snap in firmly until they click.

### Installing the Elbow Kit

When mounting the Elbow Kit, follow these steps.

1. Unlock the snap lock.
2. Dismantle the connection fittings.
3. Mount the elbows.

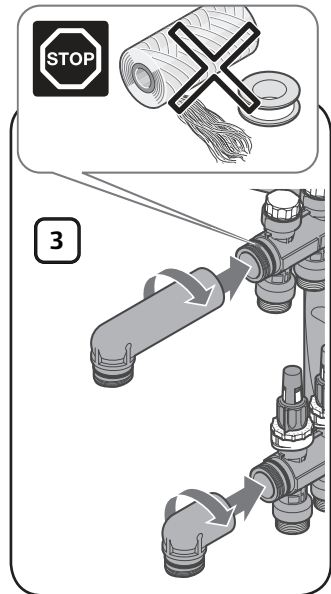
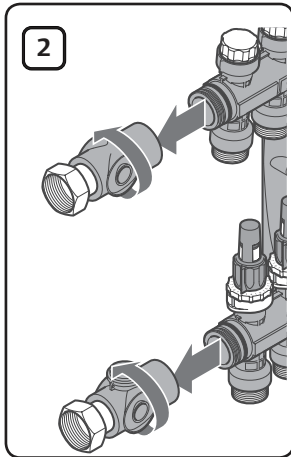
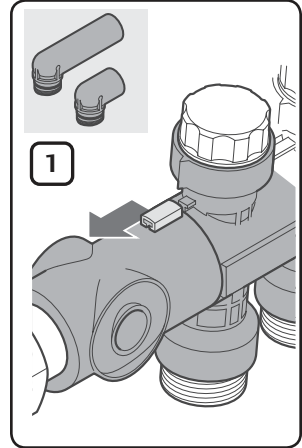

4. Mount the connection fittings.

5. Fasten the snap lock.

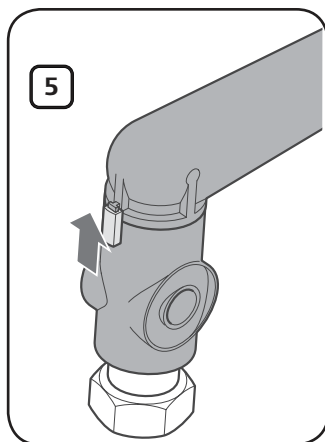
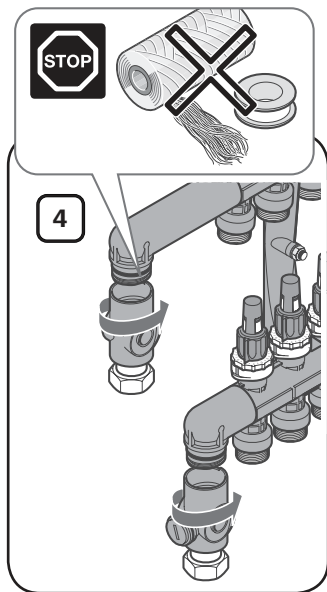

## Mounting Additional Manifold Outlets

Refer to the following instructions to properly mount one or more additional outlets on the manifold.

1. Dismantle the End Cap with Vent and Drain.
2. Mount the desired number of extra outlets and reattach the End Cap with Vent and Drain.
3. To angle some of the extra outlets in an opposite direction (e.g., up instead of down), tighten the extra outlet completely and then loosen a half turn.

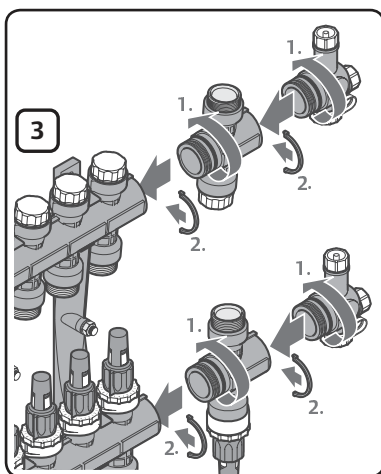
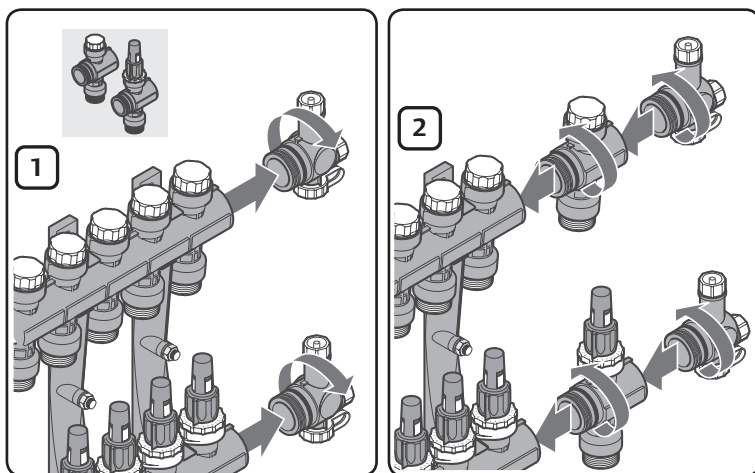

## Section 6

# Connecting Tubing to the Manifold

Connect the tubing using ProPEX or QS-style fittings. Refer to the Uponor Product Catalog for fitting information.



**Figure 6-1:** Square-cut the Tubing

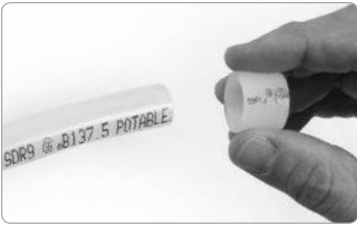

**Figure 6-2:** Slide ProPEX Ring onto Tubing



**Figure 6-3:** Expand the Tubing

1. Use a PEX Cutter (E6081125, E6081128, E6081501) to square-cut the tubing perpendicular to the tubing length.  
**Note:** Do not use a saw or similar cutting tool to cut the tubing as shavings may clog manifold valves (see **Figure 6-1**).
2. When making a ProPEX connection, insert a ProPEX Fitting Assembly into the manifold loop and tighten the fitting with a wrench.  
**Note:** When making a ProPEX connection, be sure to follow the guidelines of the ProPEX Expansion Tool you are using in your application.
3. Slide the ProPEX Ring over the end of the tubing until it reaches the stop edge.  
**Note:** Ensure the ProPEX Ring is dry and free of grease to prevent it from sliding out of place (see **Figure 6-2**).
4. Attach the proper size expander head to the tool and expand the tubing to the proper number of expansions (see **Figure 6-3** and **Table 6-1**).



Tubing Size	Milwaukee ProPEX Tool		Uponor ProPEX Tool		
	M12	M18	Manual	100 & 150	201
3/8"	8	9	5	7	—
1/2"	5	6	4	4	—
3/4"	9	8	9	9H	—
1"	13	5	14	7H	—
1 1/4"	—	7	—	7H	—
1 1/2"	—	6	—	8H	—
2"	—	—	—	—	5H

**Table 6-1:** Recommended Number of Expansions for 3/8" to 2" Tubing at 73.4°F (23°C)  
 "H" in the table refers to Uponor H-series expander heads.

**Note:** If using a Milwaukee® M12™ or M18™ ProPEX Expansion Tool, the head will auto rotate. If using an Uponor ProPEX Hand Expander Tool (Q6295075, Q6275075) without the Auto Rotation Adapter (Q6323810), you must manually rotate the tool 1/8 turn after each expansion. Proper rotation between expansions provides smooth, even expansion of the tubing. Failure to rotate will cause deep grooves in the tubing which can result in potential leak paths (see **Figures 6-4 and 6-5**).

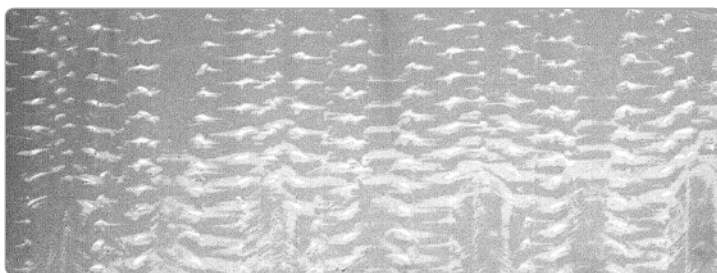

**Figure 6-4:** Expansion with Proper Rotation

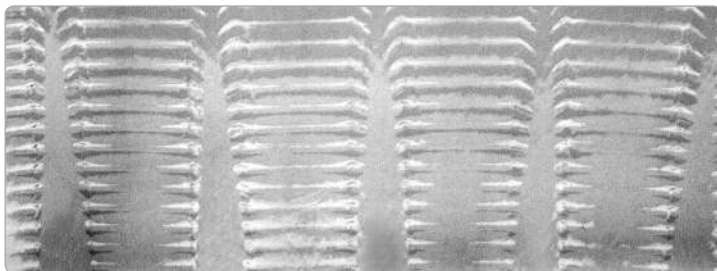

**Figure 6-5:** Expansion without Proper Rotation

- After expanding the tubing and ring, immediately remove the tool and slide the tubing over the fitting until the tubing reaches the stop on the fitting. Hold the tubing in place for two or three seconds to ensure it has time to seal to the fitting.
- When connecting the tubing with a QS-style fitting, make sure the tubing is pushed all the way into the fitting and tighten the fitting with a wrench (see **Figure 6-6**).

**Note:** Do not over-tighten or twist the tubing.

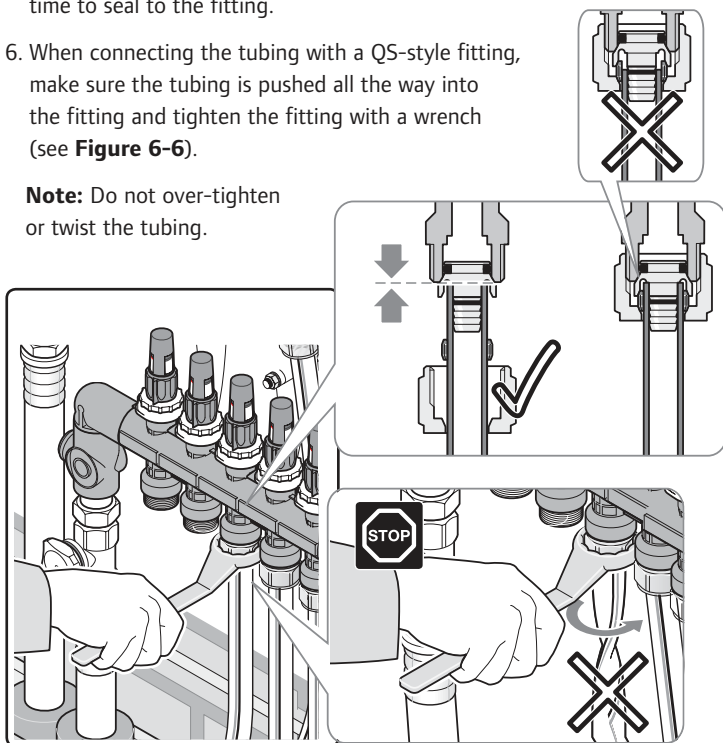

**Figure 6-6:** Push Tubing Into Fitting and Tighten with Wrench

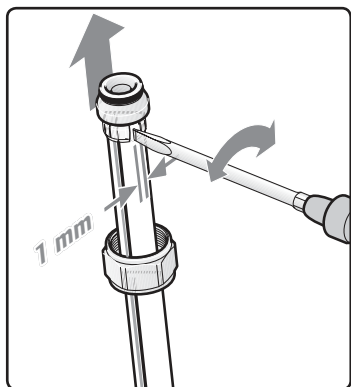

**Figure 6-7:** Use a Screwdriver to Open Clamp Ring and Remove Fitting

- If you need to remove a QS-style fitting from the tubing, use a screwdriver to open the clamp ring and remove the insert (see **Figure 6-7**).
- When all tubing is connected to the manifold, measure the length of each loop (subtract the length marking on the return line from the supply line, or vice versa). Record the measurements in **Section 12: Manifold Balancing Form**. This information will be needed for balancing the manifold.

## Section 7

# Filling and Purging the Manifold

To ensure the manifold provides enough water for superior performance, fill and purge the system at the boiler or at the manifold.

If you choose to fill and purge at the manifold, see the following instructions.

1. Connect a water hose from a faucet to the fill valve on the supply manifold cap.
2. Connect a separate drain hose to the cap on the return manifold and place the other end into a large bucket or into a drain.
3. Close all valves on the manifold (both supply and return manifold), as well as the Supply and Return Ball Valve (A2631252) installed on the supply and return lines.
4. Open the valves for the first loop on the manifold.

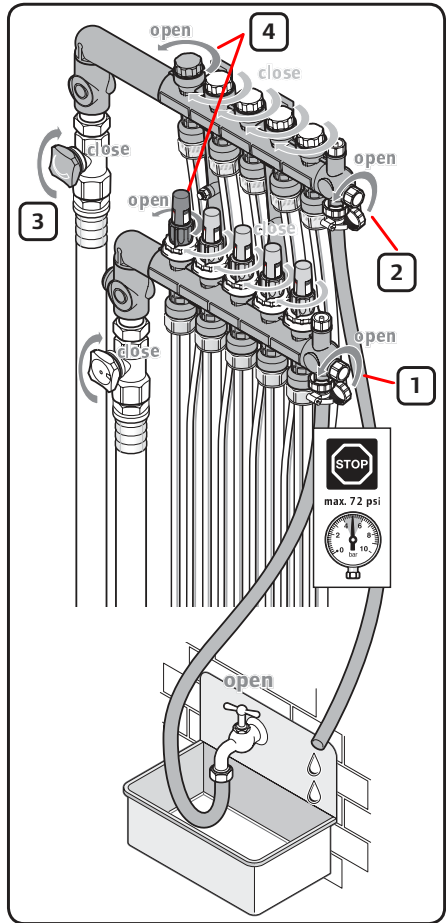

5. Fill the loop with water and let the water flow until the water coming out of the hose is clear (i.e., no bubbles appear).
6. Repeat **Steps 1** through **5** to fill and purge each manifold loop.

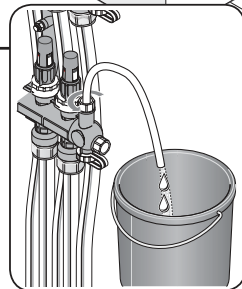
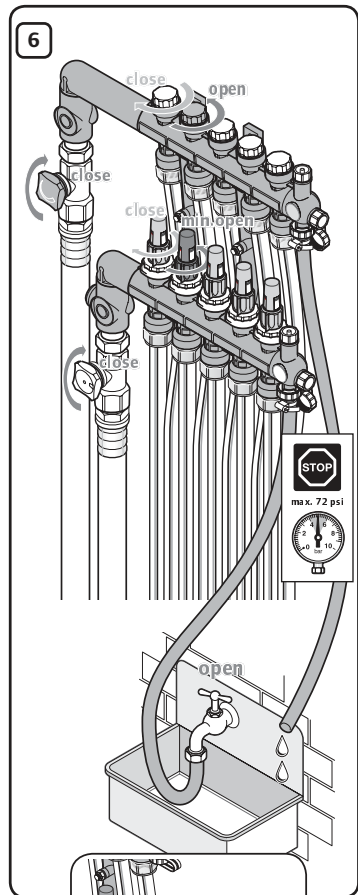
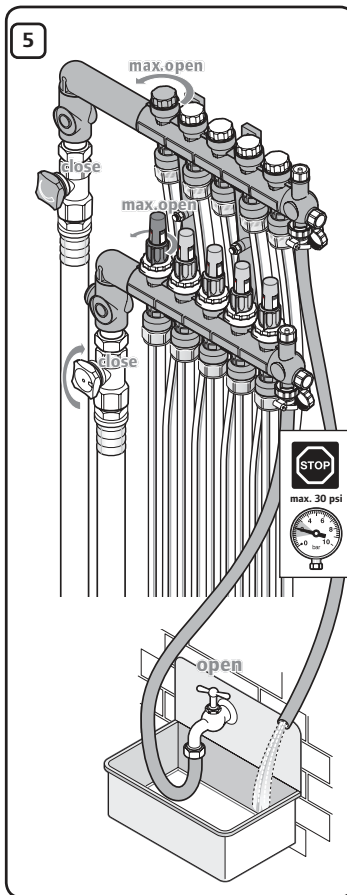

## Section 8

# Pressure Testing

To ensure the system is installed correctly and operating properly, it is important to pressure test the system. There are several options to pressure test a system, including air and water. However, air provides a much more rigorous test.



1. To ensure all valves are working accurately, open and close all valves twice. Make sure all manifold isolation and flow valves are open.



**Note:** Manifold Supply and Return Ball Valves should be closed during the pressure test procedure.



2. Connect the Uponor Manifold Pressure Test Kit (E6122000) or other pressure test device. Uponor recommends a test pressure of 3 times the operating pressure, or at least 40 psi.

**Note:** Maximum pressure when testing with air should not exceed 120 psi.

3. Visually check for leaking and monitor the pressure for the duration specified by local code. (A typical pressure test can range from 2 to 24 hours.)
4. If there is no reduction in pressure, the system is regarded as sealed.
5. After completing the pressure test, set the operating pressure.

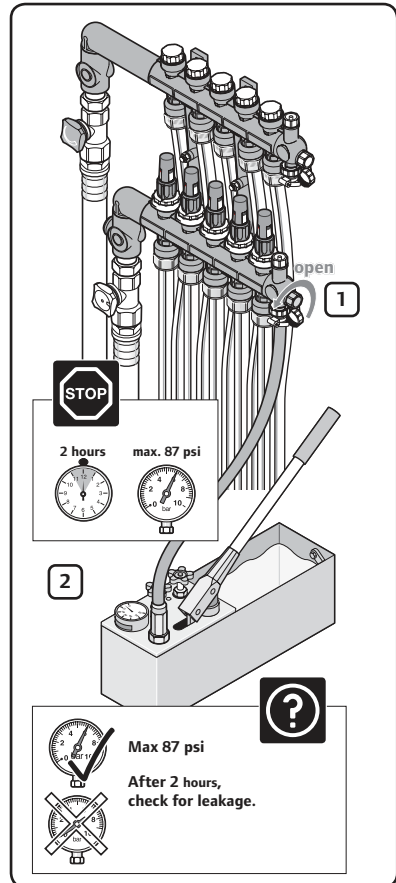

## Section 9

# Adjusting Manifold Valves

Balance the manifold system to ensure superior performance.

1. Use the manifold flow meters to balance the system.
2. Make sure the system is in operation and water is flowing through the manifold.
3. Turn the balancing valve until the desired flow in the loop is obtained.



**Note:** Visually check the flow meter window to ensure proper flow.

4. Lift and turn the adjustment ring to the set valve position and push it back down into the locked position.

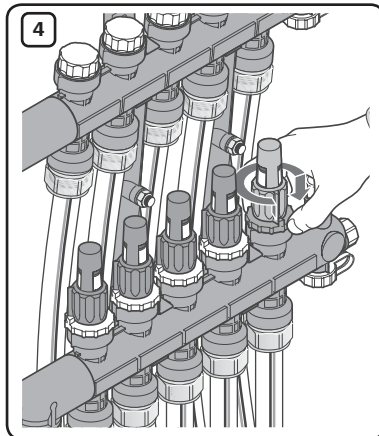
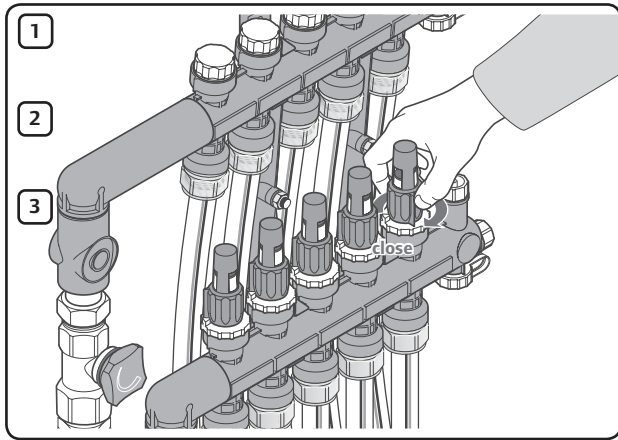

## Section 10

# Manifold Maintenance

The EP Heating Manifold does not require a maintenance schedule. However, Uponor recommends checking system components regularly.

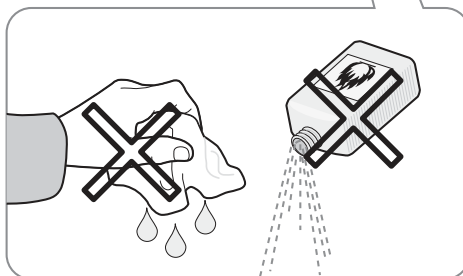
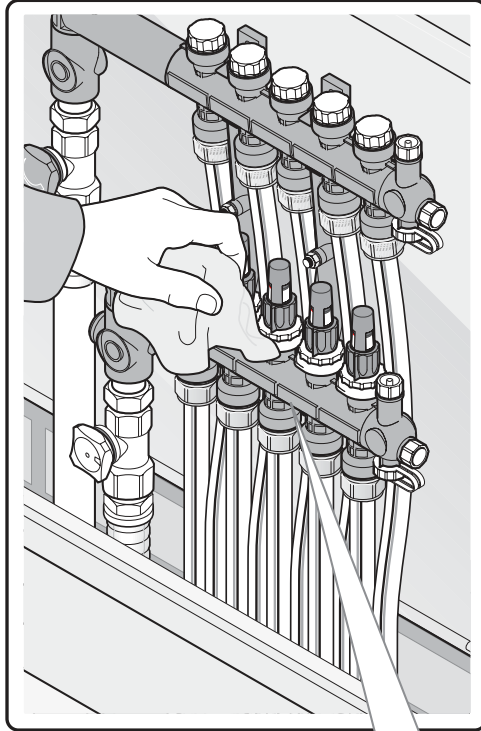

Use a soft, dry cloth to clean the manifold as needed.

Do not use a damp cloth or cleaning agents.

## Section 11

# Technical Data

Technical Data	
Connection Dimensions	R32
Max. Operating Temperature and Pressure	
6 bar at 60°C 87 psi at 140°F	
5 bar at 70°C 72 psi at 158°F	
4 bar at 80°C 58 psi at 176°F	
3 bar at 90°C 44 psi at 194°F	
Max. Test Pressure (24 h, ≤ 86°F)	10 bar/145 psi
Max. Water Flow per Manifold	0.97 L/s or 15.4 gpm
Cv Value Inlet/Outlet Valves	1.40
Adaptable Thermal Actuators	EP Heating Manifold Two-wire Actuator (A3030522) or Thermal Actuator, four wire (A3010522) with EP Heating Manifold Actuator Adaptor (A2671300)
Available Sizes	2 to 8 heating/cooling loop connections

**Table 11-1: Technical Data**



## Chemicals



Do not use the chemicals outlined in **Table 11-2** with the EP Heating Manifold.

Chemical	Common Uses
Acetaldehyde	Disinfectants, Air Deodorizers, Lacquers/Varnishes
Acetone	Varnish Remover, General Solvent
Acids	Any situation requiring a high concentration of acidic chemicals
Aluminum Salts of Mineral Acids	
Ammonia	Cleansers, Bleach, Fertilizers
Ammonium Chloride	Adhesives, Shampoo
Ammonium Hydroxide	Cleansers, Bleach
n-Amyl Acetate	Paint and Lacquer Removers
Barium Chloride	Dyes, Pesticides
Bromine	Disinfectants, Dyes, Fuel Additives, Pesticides
n-Butanol	Paint Thinners
Calcium Chloride	Antifreeze, Fire Extinguishers
Calcium Thiocyanate	Water Treatment (pool)
Chlorine (Concentrated)	Water Treatment
Chloroform	Fire Extinguishers, Dyes, Pesticides
Chlorox	Bleach
m-Cresol	Disinfectants, Insecticides, Photography Developers
Ethylene Dibromide	Insecticides, Fuel Additives
Ethylene Glycol	Antifreeze/coolant
Hexafluoroisopropanol	Electronics Cleansers
Hydrogen Peroxide	Disinfectants
Hydrogen Sulfide	Fuels
Methylene Chloride	Paint Removers, Degreasers, Aerosol Foam Sprays, Pesticides
Phenol	Disinfectants, Herbicides
Potassium Carbonate	Adhesives, Bleach, Cleansers
Potassium Permanganate	Disinfectants, Water Treatment (Pools)
Potassium Thiocyanate	Dyes, Photography Developers
Sodium Hydroxide	Paint Removers, Cleansers, Lye, Drain Cleaners
Sodium Hypochlorite	Bleach, Disinfectants
Stannic Chloride	Dyes, Soaps
Stannic Sulfate	Gypsum, Lacquer/Varnish
Sulfur Dioxide	Bleach
Tetrafluoropropane	Refrigerants, Lubricants

**Table 11-2: Chemicals Inappropriate with EP Heating Manifold**

## Section 12

# Manifold Balancing Form

When all tubing is connected to the manifold, measure the length of each loop (subtract the length marking on the return line from the supply line, or vice versa). Record the measurements in the form below as this information is needed for balancing.



· Project \_\_\_\_\_

· Date \_\_\_\_\_

· Floor No. \_\_\_\_\_

· Manifold No. \_\_\_\_\_

Room No. \_\_\_\_\_

Room Designation

Heating Loop No.

Valve Setting/  
Water Flow (gpm/ <sup>l</sup>/s)

Start No. of Feet/Meters

End No. of Feet/Meters

Effective Tubing Length

	1	2	3	4	5	6	7	8	9	10	11	12
Room Designation	<input type="text"/>	<input type="text"/>	<input type="text"/>	<input type="text"/>	<input type="text"/>	<input type="text"/>	<input type="text"/>	<input type="text"/>	<input type="text"/>	<input type="text"/>	<input type="text"/>	<input type="text"/>
Heating Loop No.	<input type="text"/>	<input type="text"/>	<input type="text"/>	<input type="text"/>	<input type="text"/>	<input type="text"/>	<input type="text"/>	<input type="text"/>	<input type="text"/>	<input type="text"/>	<input type="text"/>	<input type="text"/>
Valve Setting/ Water Flow (gpm/ <sup>l</sup> /s)	<input type="text"/>	<input type="text"/>	<input type="text"/>	<input type="text"/>	<input type="text"/>	<input type="text"/>	<input type="text"/>	<input type="text"/>	<input type="text"/>	<input type="text"/>	<input type="text"/>	<input type="text"/>
Start No. of Feet/Meters	<input type="text"/>	<input type="text"/>	<input type="text"/>	<input type="text"/>	<input type="text"/>	<input type="text"/>	<input type="text"/>	<input type="text"/>	<input type="text"/>	<input type="text"/>	<input type="text"/>	<input type="text"/>
End No. of Feet/Meters	<input type="text"/>	<input type="text"/>	<input type="text"/>	<input type="text"/>	<input type="text"/>	<input type="text"/>	<input type="text"/>	<input type="text"/>	<input type="text"/>	<input type="text"/>	<input type="text"/>	<input type="text"/>
Effective Tubing Length	<input type="text"/>	<input type="text"/>	<input type="text"/>	<input type="text"/>	<input type="text"/>	<input type="text"/>	<input type="text"/>	<input type="text"/>	<input type="text"/>	<input type="text"/>	<input type="text"/>	<input type="text"/>

# Notes

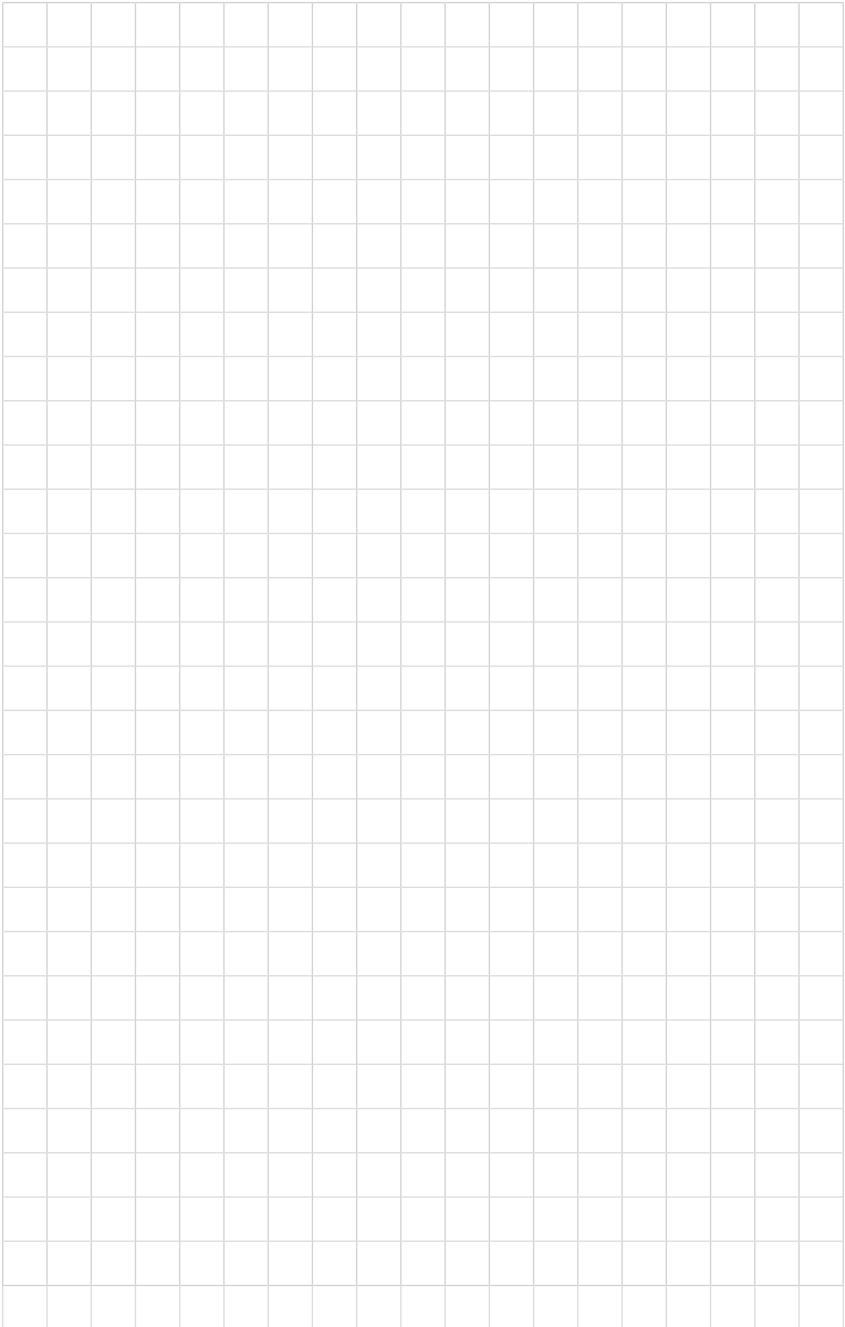

**Uponor, Inc.**

5925 148th Street West  
Apple Valley, MN 55124 USA  
Tel: 800.321.4739  
Fax: 952.891.2008

**Uponor Ltd.**

2000 Argentia Rd., Plaza 1, Ste. 200  
Mississauga, ON L5N 1W1 CANADA  
Tel: 888.994.7726  
Fax: 800.638.9517

**Uponor**

[www.uponorpro.com](http://www.uponorpro.com)