

uponor

RADIANT HEATING AND
COOLING SYSTEMS

**STAINLESS-STEEL
MANIFOLD**

INSTALLATION GUIDE

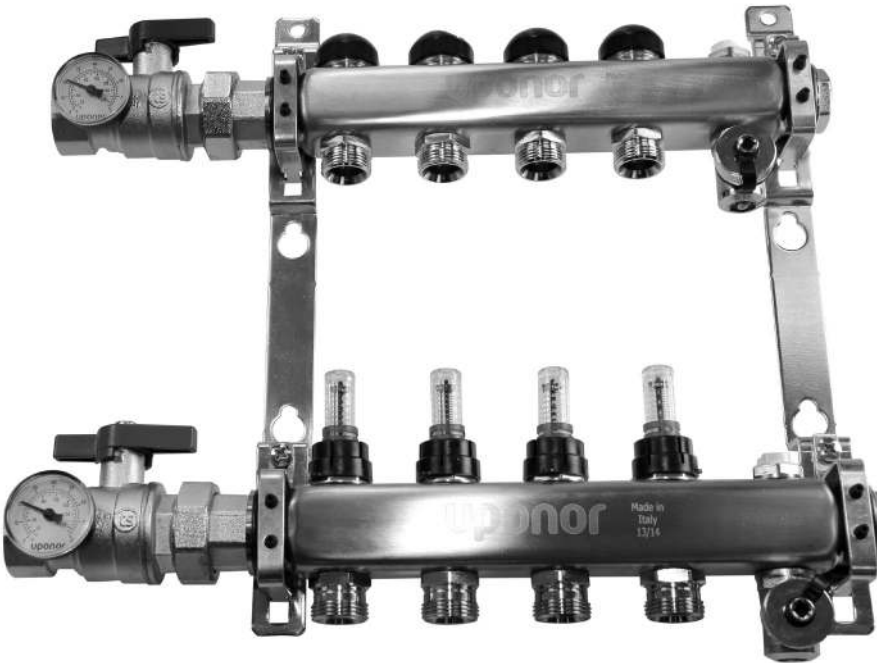

Stainless-steel Manifold
Installation Guide

Stainless-steel Manifold Installation Guide

Published by Uponor North America

5925 148th Street West

Apple Valley, MN 55124 USA

Phone: 800.321.4739

Fax: 952.891.2008

www.uponorpro.com

© 2014 Uponor North America

All Rights Reserved.

First Edition April 2014

First Printing April 2014

Printed in the United States of America

Stainless-steel Manifold Installation Guide

Overview

Featuring 2 through 8, 10 and 12 loops, the Uponor Stainless-steel Manifold comes fully assembled with flow meters, temperature gauges, ball valves and NPT connections.

Note: The valve body with the preassembled flow meters is the supply manifold; the valve body without the flow meters is the return manifold.

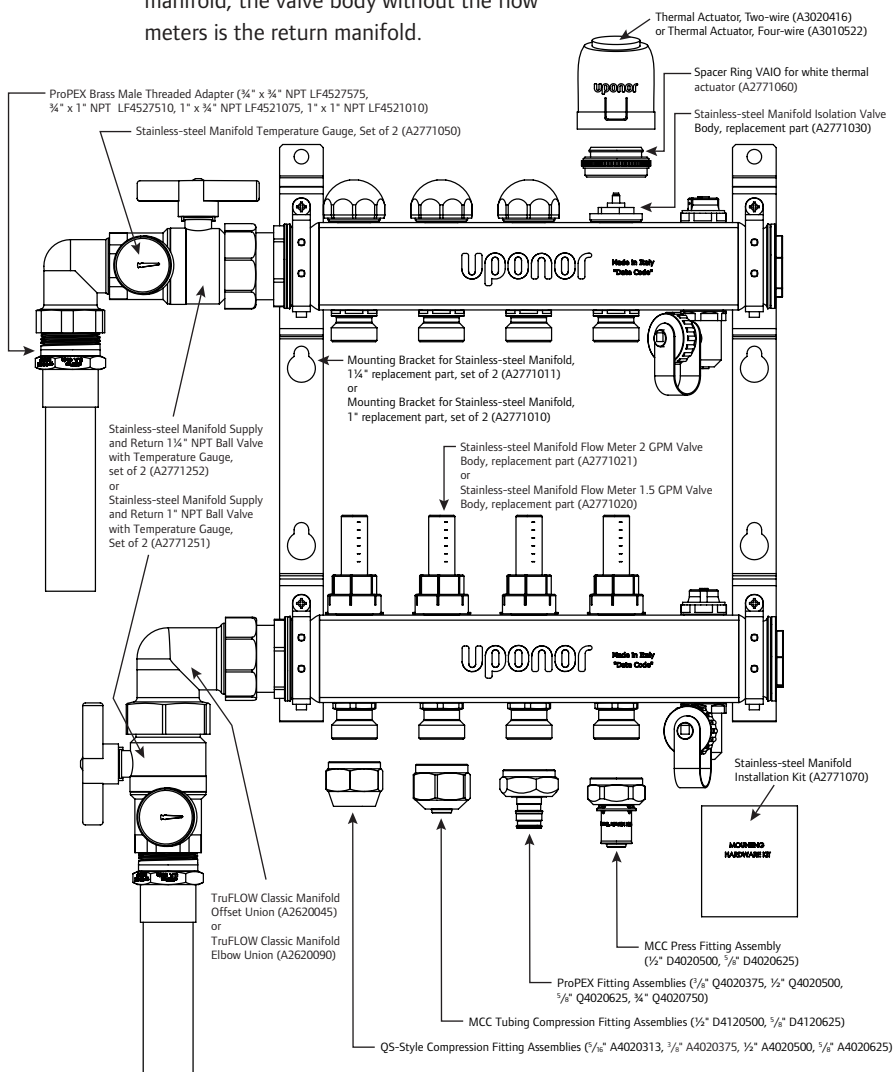

Mounting Manifold to a Wall

1. Fasten the manifold to a wall using a rigid anchor and mounting screws (included).

Mounting Manifold Inside a Wall Cabinet

1. Insert the cage nuts (included) in the mounting rail.
2. Align the manifold bracket holes with the cage nuts in the rail and loosely fasten with bolts (included).
3. Slide the manifold into the desired position and tighten the bolts.

Note: For wall cabinet mounting instructions, refer to the Uponor Manifold Wall Cabinet Instruction Sheet.

Note: When installing the Stainless-steel Manifold with 10 or 12 loops, adjust mounting bracket spacing for proper fit on cabinet rail.

Distribution Pipe

The Stainless-steel Manifold Assembly comes standard with loosley fitted Manifold Supply Ball Valves. Follow the below direction to install a NPT transition fitting, manifold elbow union, or manifold offset union connection. Refer to the Uponor Product Catalog for fitting information.

- Stainless-steel Manifold Supply and Return 1" NPT Ball Valve with Temperature Gauge, set of 2 (A2771251) comes standard on all 1" Stainless-steel Manifold assemblies and 1¼" manifolds with 2 through 7 loops.
- Stainless-steel Manifold Supply and Return 1¼" NPT Ball Valve with Temperature Gauge, set of 2 (A2771252) comes standard on all 1¼" Manifold 8, 10 and 12 loops.

Note: Make NPT connections prior to R32 union connections to insure proper orientation.

When using NPT Transition Fittings

1. Apply pipe dope or Teflon tape to NPT X ProPEX® transition fitting threads into FNPT ball valve thread.
2. Adjust Manifold Supply and Return Ball Valve to proper orientation and tighten.

Note: An NPT x NPT reducing coupling may be required to adapt 1" or 1¼" FNPT thread-on ball valve to ditribution piping (supplied by other).

When using Manifold Elbow or Offset Union Connections (A2620090 or A2620045)

1. Remove the loosely fitted Manifold Supply and Return Ball Valves.
2. Thread Manifold Elbow Union (A2620090) or Manifold Offset Union (A2620045) connection into the Stainless-steel Manifold Assembly's R32 union connection with a flat gasket.
3. Thread Manifold Supply and Return Ball Valve (A2771251 or A2771252) into the R32 union connection on the Manifold Elbow or Offset Union Connection with a flat gasket.
4. Apply pipe dope or teflon tape to NPT x ProPEX transition fitting threads and thread into FNPT ball valve thread.
5. Adjust Manifold Elbow Union or Manifold Offset Union connection as well as the Manifold Supply and Return Ball Valve to proper orientation and tighten.

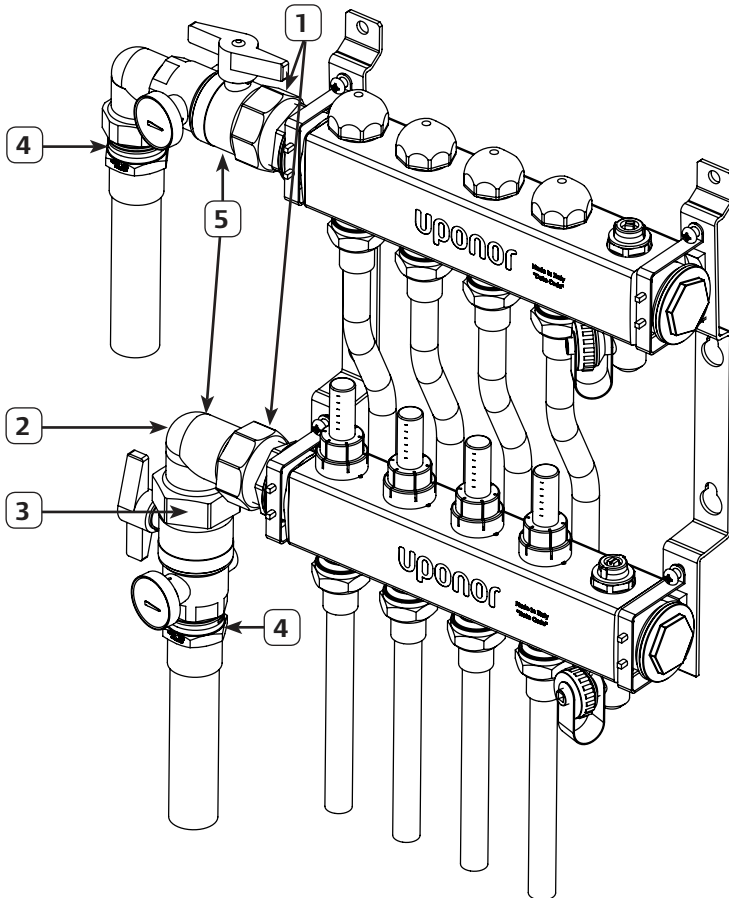

Connecting Tubing to the Manifold

Connect the tubing to the manifold using either the ProPEX connection method or QS-style fittings. Refer to the Uponor Product Catalog for fitting information.

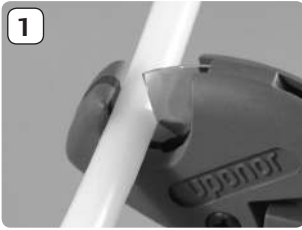

Square-cut the Tubing

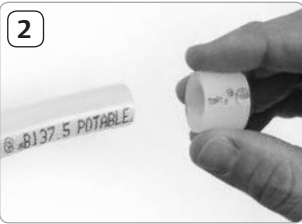

Slide ProPEX Ring onto Tubing



Expand the Tubing

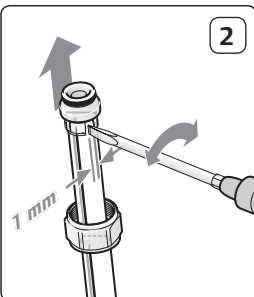

Use a Screwdriver to Open Clamp Ring and Remove Fitting

ProPEX Connections

1. Use a PEX Cutter (E6081125, E6081128 or E6081501) to square-cut the tubing perpendicular to the tubing length.
Note: Do not use a saw or similar cutting tool as shavings may clog the manifold valves.
2. Slide the ProPEX Ring over the end of the tubing until it reaches the stop edge.
Note: Ensure the ring is dry and free of grease to prevent it from sliding out of place.
3. Attach the proper size ProPEX Expander Head onto the expander tool and expand the tubing with the proper number of expansions (see **Table 1**).
4. After expanding the tubing and ring, immediately remove the expander tool and slide the tubing over the fitting until the tubing reaches the stop on the fitting. Hold the tubing in place for two or three seconds to ensure a proper seal.

QS-style Fittings

1. When connecting the tubing with a QS-style fitting, make sure the tubing is pushed all the way into the fitting and tighten the fitting with a wrench.
Note: Do not over-tighten or twist the tubing.
2. If you need to remove a QS-style fitting from the tubing, use a screwdriver to open the clamp ring and remove the insert.

Tubing Size	Milwaukee® ProPEX Tool		Uponor ProPEX Tool	
	M12	M18	Manual	100 & 150
3/8"	8	9	5	7
1/2"	5	6	4	4
3/4"	9	8	9	9H*

Table 1: Recommended Number of ProPEX Expansions
*H refers to Uponor H-series expander heads.

Filling and Purging the Manifold

To ensure proper system performance, it is important to fill and purge the system at the boiler or at the manifold. Refer to the following instructions to fill and purge at the manifold.

1. Connect a hose from a faucet to the fill valve on the supply manifold.
2. Connect a separate drain hose to the return manifold and place the other end into a large bucket or drain.
3. Remove the flow meter locking cover.
4. Close all valves on the manifold (both supply and return) as well as the ball valves (A2771251 or A2771252) installed on the supply and return lines.
5. Use the square tool on the cap of the hose bib fill port to open the fill valves on the supply and return manifold.
6. Open the valves for the first loop on the manifold.
7. Fill the loop with water. Continue the filling process until the water is clear with no bubbles.
8. Repeat Steps 4 through 6 to fill and purge each manifold loop.
9. Replace the flow meter locking cover.

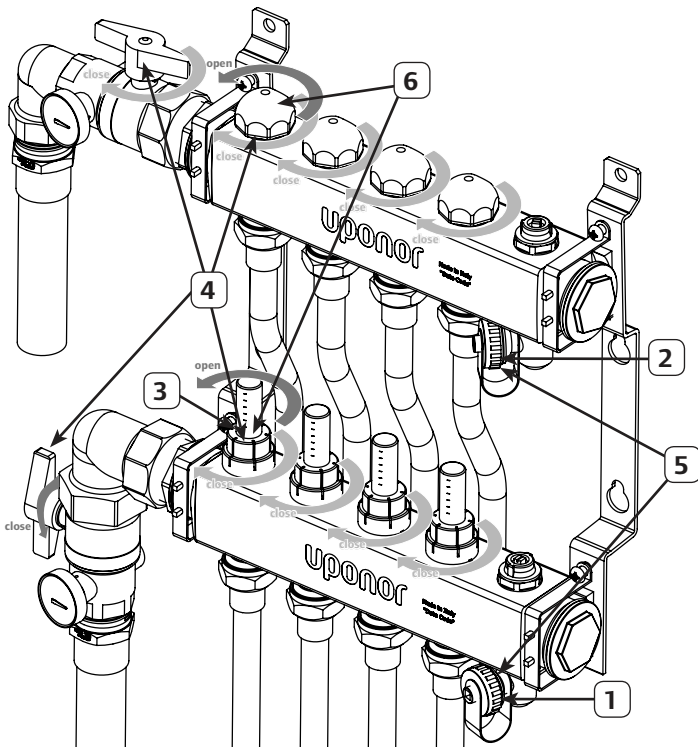

Pressure Testing

To ensure the system is installed correctly and operating properly, it is important to pressure test the system. There are several options to pressure test a system, including air and water. However, air provides a much more rigorous test.

1. To ensure all valves are working accurately, open and close all valves twice. Make sure all manifold isolation and flow valves are open.

Note: Manifold Supply and Return Ball Valves should be closed during the pressure test procedure.

2. Connect the Uponor Manifold Pressure Test Kit (E6122000) or other pressure test device. Uponor recommends a test pressure of 3 times the operating pressure, or at least 40 psi.

Note: Maximum pressure when testing with air should not exceed 100 psi.

3. Visually check for leaking and monitor the pressure for the duration specified by local code. (A typical pressure test can range from 2 to 24 hours.)
4. If there is no reduction in pressure, the system is regarded as sealed.
5. After completing the pressure test, set the operation pressure.

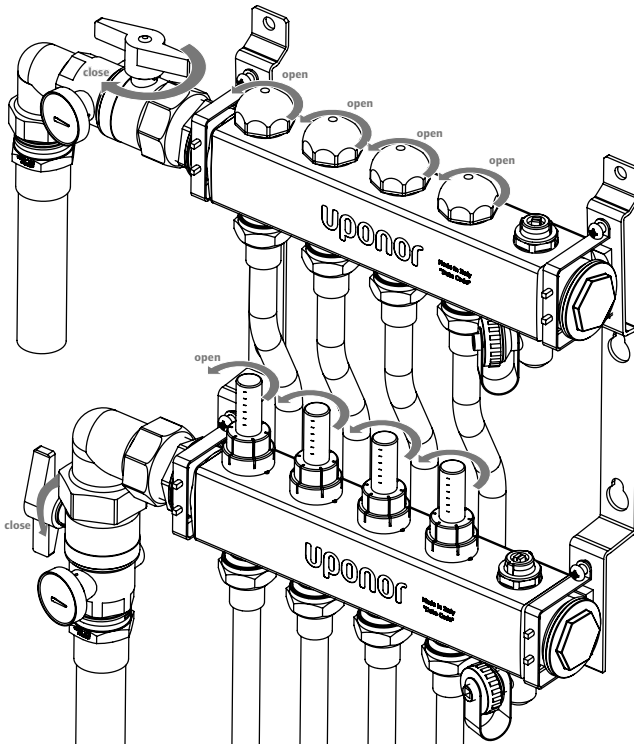

Balancing the Manifold

Balancing the manifold helps to ensure proper system performance.

1. Ensure the system is operating and water is flowing through the manifold.
2. Remove the flow meter's locking cover.
3. Turn the balancing valve to obtain the desired flow.

Note: Visually check the flow meter window to ensure proper flow.

4. Replace the flow meter cover to set the valve position and push it down into the locked position.

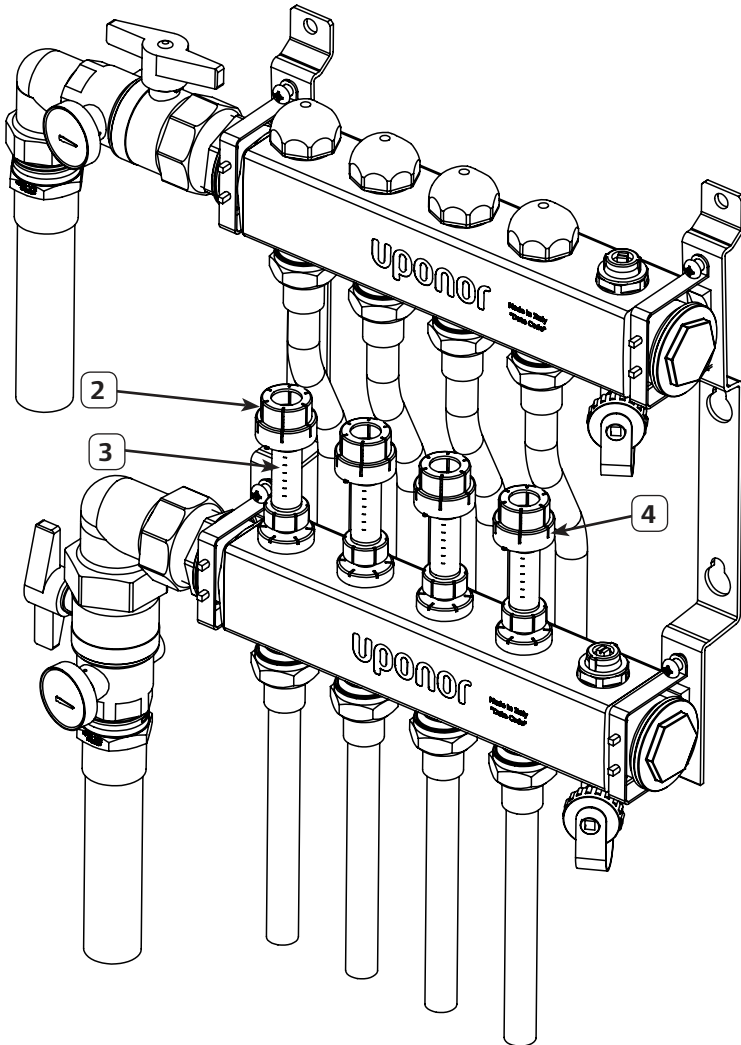

Uponor, Inc.

5925 148th Street West
Apple Valley, MN 55124 USA
Tel: 800.321.4739
Fax: 952.891.2008

Uponor Ltd.

2000 Argentia Rd., Plaza 1, Ste. 200
Mississauga, ON L5N 1W1 CANADA
Tel: 888.994.7726
Fax: 800.638.9517

Uponor

www.uponorpro.com