



## CONSTRUCTO 1.0 HRV

Part no. 41502 (TOP PORTS)

Part no. 41500 (SIDE PORTS)

39 to 98 CFM (0.4 in. w.g.)



VB0069

### AN INGENIOUS AIR EXCHANGE SOLUTION THAT'S AS VERSATILE AS IT IS COMPACT!

Configured with factory built vertical or horizontal ports, the AVS Constructo 1.0 HRV is the most versatile 98-cfm unit available on the market today. Among its exclusive features, this unit is equipped with integrated balancing and backdraft dampers in its exhaust to outside and fresh air supply ports. For a standard installation, there is no need to balance the unit\*, thanks also to its twin high-pressure blowers. Its operation can be interlocked with an existing furnace without adding an extra relay. Also, for more convenience, its latches can be relocated on its front (as shown on unit picture). This compact, lightweight, and powerful unit is the ideal choice for small single-family homes, high rise residential building and other limited space applications. What's more, it is the only air exchanger of its size that can be upgraded from an HRV to an ERV, simply by changing its core.

\*To avoid balancing, the difference between stale air ducts total length and fresh air ducts total length must not exceed 50 ft.

- Versatile horizontal or vertical port configuration
- Removable terminal block to ease optional wall control connections
- Integrated pressure taps, if balancing required by building code
- ENERGY STAR® qualified

### REPAIRS AND MAINTENANCE

All parts of the AVS Constructo 1.0 HRV that could need maintenance can be removed in less than 5 minutes, allowing direct access for easy repairs. The PSC motors are permanently lubricated. Finally, the removable electrical drawer with pull-out PCB assembly allows easy access for maintenance of major sub-components.

### WARRANTY

The AVS Constructo 1.0 HRV is protected by a 2-year warranty on parts only. The heat recovery core is covered by a lifetime warranty.

Available at:

# HEAT RECOVERY VENTILATOR

### Controls

- This unit is very simple to operate: once it is installed, press on its push button, located on the bottom of the unit, to activate it. Press once for low speed, once again for high speed, and once more to stop it
- The following main controls are available:
  - Altitude programmable digital control with SMART mode no. 40440
  - Deco-Touch digital control no. 40395
  - Constructo no. 40350
  - Lite-Touch Constructo no. 40370
  - Simple-Touch Constructo no. 40390
- Up to 5 of the following optional auxiliary controls can also be added:
  - 20-min. lighted push button no. 12030
  - 60-min. mechanical timer no. 00910

### Options

- Complete line of registers and diffusers
- Electric duct heater
- Dual exterior hood kit (including the Tandem® transition), part no. 14690

### Homeshield™ Defrosting System

The AVS Constructo 1.0 HRV uses a unique defrosting method. No negative pressure is created by air exhausted to the outside, as the air is recirculated into the house, helping to prevent any backdraft.

STALE AIR FROM BUILDING	OUTSIDE TEMPERATURE		DEFROST CYCLE DEFROSTING MIN./ OPERATING MIN.
	°C	°F	
FILTERED AIR TO BUILDING	WARMER THAN -5	WARMER THAN 23	NO DEFROST
	-5 TO -27	23 TO -17	8/25
	-27 & LESS	-17 & LESS	10/22

### Heat Recovery Core

Dimensions: 13" x 19" x 6 7/8" (33 cm x 48.3 cm x 17.3 cm)  
 Exchange surface: 55 ft<sup>2</sup> (5.1 m<sup>2</sup>)  
 Weight: 3.75 lb (1.7 kg)  
 Material: Polypropylene  
 Type: Crossflow  
 Warranty: Limited Lifetime

### Requirements and Standards

- Complies with the UL 1812 requirements regulating the installation of Heat Recovery Ventilators
- Complies with the CSA C22.2 no. 113 Standard applicable to ventilators
- Complies with CSA C444 requirements regulating the installation of Heat Recovery Ventilators
- Technical data was obtained from published results of tests relating to CSA C439 Standards
- HVI certified and ENERGY STAR® qualified

## Dimensions: AVS Constructo 1.0 HRV (ports on sides)

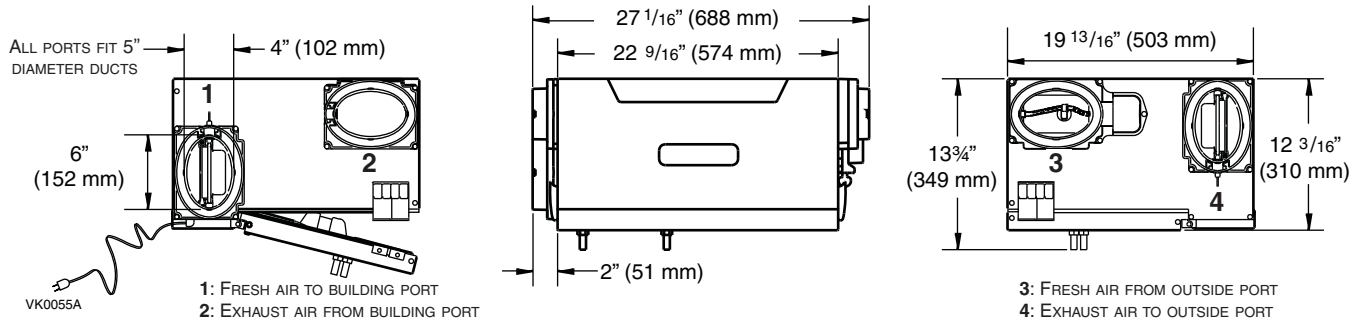

## Ventilation Performance

EXT. STATIC PRESSURE	NET SUPPLY AIR FLOW					GROSS AIR FLOW					
	PA	IN. W.G.	L/S	CFM	M <sup>3</sup> /H	SUPPLY			EXHAUST		
						L/S	CFM	M <sup>3</sup> /H	L/S	CFM	M <sup>3</sup> /H
25	0.1	53	111	191	53	112	190	57	120	204	
50	0.2	51	107	184	51	108	184	54	114	194	
75	0.3	48	101	172	48	102	173	52	110	187	
100	0.4	46	98	167	47	99	168	49	105	178	
125	0.5	43	91	155	43	92	156	47	100	170	
150	0.6	41	88	148	42	88	151	45	96	163	
175	0.7	39	82	139	39	83	141	43	91	155	
200	0.8	37	79	134	38	80	136	40	85	144	
225	0.9	34	73	124	35	74	126	37	79	134	
250	1.0	34	71	121	34	72	122	36	76	129	

## Energy Performance

SUPPLY TEMPERATURE	NET AIR FLOW			POWER CONSUMED WATTS	SENSIBLE RECOVERY EFFICIENCY	APPARENT SENSIBLE EFFECTIVENESS	LATENT/RECOVERY MOISTURE TRANSFER	
	°C	°F	L/S					CFM
HEATING								
0	32	23	50	85	43	65	74	0.01
0	32	30	64	109	58	62	70	0.01
0	32	39	83	141	70	59	66	0.01
-25	-13	21	45	76	56	60	78	0.01
-25	-13	30	64	109	64	55	72	0
COOLING								
35	95	-	-	-	TOTAL RECOVERY EFFICIENCY			NOT TESTED

NOTE: All specifications are subject to change without notice.

## Specifications and Ratings

- Model: AVS Constructo 1.0 HRV
- Part Number top ports: 41502
- Part Number side ports: 41500
- Total Assembled Weight (including polypropylene core): 42 lb (19 kg)
- Oval shaped ports; fit 5" dia. ducts
- Drains: 1/2" (1.2 cm) fittings with 10 ft (3 m) PVC drain
- Core filters: 30 ppi washable foam 10.5" x 6.75" x 0.5" (26.7 cm x 17.2 cm x 1.3 cm)

- Housing: Pre-painted steel
- Insulation: Expanded polystyrene
- Mounting: Suspension by chains and springs
- Supply & Exhaust Blower Motors: 2 motors
  - Protection type: Thermally protected
  - Insulation class: B

- Speed Control on unit: Low & High speed. Other modes available with main and optional wall controls.
- Heat Recovery Core:
  - Heat Exchange Surface Area: 55 ft<sup>2</sup> (5.1 m<sup>2</sup>)
  - Type/Material: Crossflow/Polypropylene
- Unit Electrical Characteristics:
 

Volts	Frequency	Ampere	Watts
120	60 Hz	0.85	100

## AVS Constructo 1.0 HRV (ports on top)

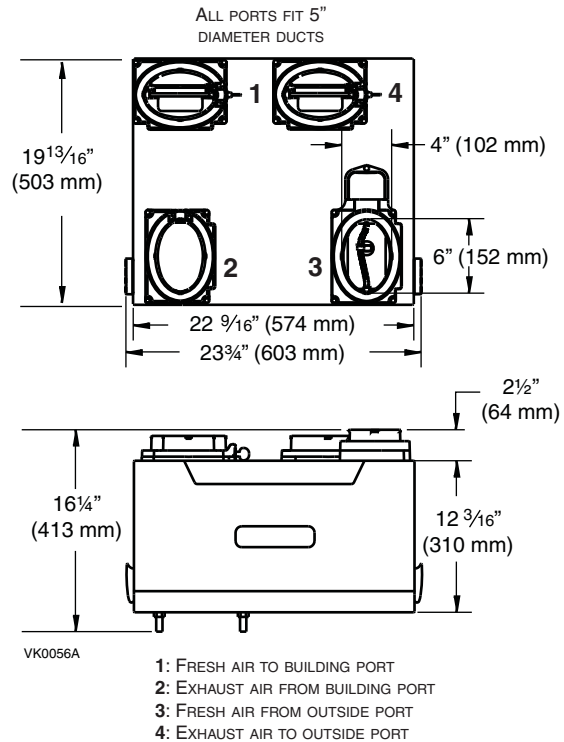

PROJECT:	REMARKS
LOCATION:	
MODEL NO.:	
QTY.:	
SUBMITTED BY:	DATE:



Residential Product Group, 550 Lemire Blvd., Drummondville, QC, Canada J2C 7W9 - Tel.: 1-800-567-3855 Fax: 1-800-567-1715



www.venmar.ca

12/07 PRODUCT SHEET NO. 91047