

# INSTALLATION GUIDE FOR VENMAR AVS UNITS CONSTRUCTO 1.2 ERV AND väänEE 60H+ ERV

**Model no.: 41556  
(ERV with top ports)**

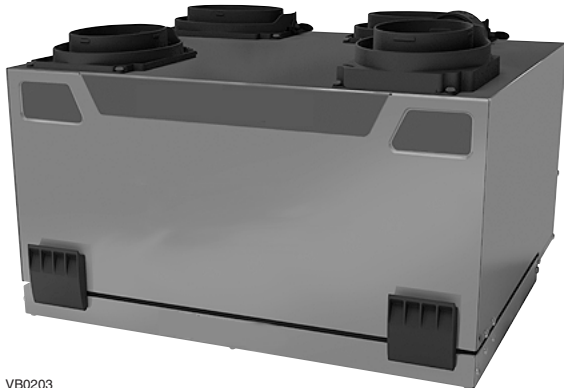

VB0203

**Model no.: 41656  
(ERV with top ports)**

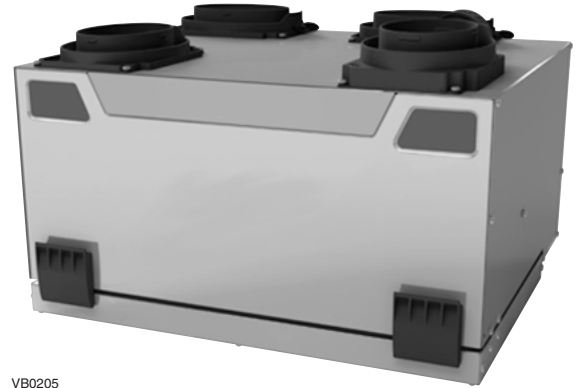

VB0205

**Model no.: 41554  
(ERV with side ports)**



VB0204

**Model no.: 41654  
(ERV with side ports)**

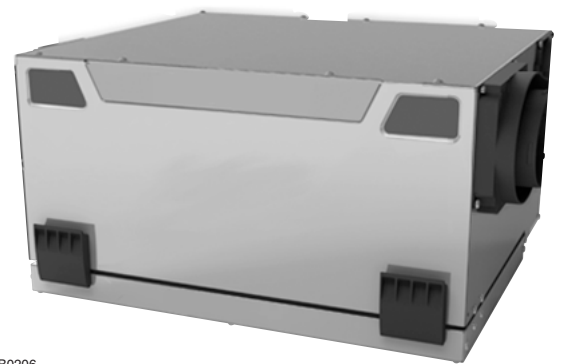

VB0206

**⚠ RESIDENTIAL USE ONLY ⚠**

**READ AND SAVE THESE INSTRUCTIONS**



7 72371 13081 4



These products earned the ENERGY STAR® by meeting strict energy efficiency guidelines set by Natural Resources Canada and the US EPA. They meet ENERGY STAR requirements only when used in Canada.

## ABOUT THIS MANUAL

Because of the large amount of models covered by this publication, the illustrations are typical ones. Some details of your unit may be slightly different than the ones shown.

Please take note that this manual uses the following symbols to emphasize particular information:

### **⚠ WARNING**

**Identifies an instruction which, if not followed, might cause serious personal injuries including possibility of death.**

### **CAUTION**

**Identifies an instruction which, if not followed, may severely damage the unit and/or its components.**

NOTE: Indicates supplementary information needed to fully complete an instruction.

We welcome any suggestions you may have concerning this manual or the unit, and we would appreciate hearing your comments on ways to better serve you. Please contact us by phone at 1-800-567-3855.

## ABOUT THESE UNITS

### LIMITATION

For residential (domestic) installation only. Installation work and electrical wiring must be done by a qualified person(s) in accordance with all applicable codes and standards, including fire-rated construction codes and standards.

### **⚠ WARNING**

#### **TO REDUCE THE RISK OF FIRE, ELECTRIC SHOCK, OR INJURY TO PERSON(S) OBSERVE THE FOLLOWING:**

1. Use this unit only in the manner intended by the manufacturer. If you have questions, contact the manufacturer at the address or telephone number listed in the warranty.
2. Before servicing or cleaning the unit, disconnect power cord from electrical outlet.
3. This unit is not designed to provide combustion and/or dilution air for fuel-burning appliances.
4. When cutting or drilling into wall or ceiling, do not damage electrical wiring and other hidden utilities.
5. Do not use this unit with any solid-state speed control device other than following wall controls:

UNIT	MAIN CONTROL	AUXILIARY CONTROLS
VENMAR AVS CONSTRUCTO 1.2 ERV	ALTITUDE, DECO-TOUCH, LITE-TOUCH CONSTRUCTO, SIMPLE-TOUCH CONSTRUCTO OR CONSTRUCTO	DEHUMIDISTAT, 20-MINUTE LIGHTED PUSH-BUTTON TIMER AND 60-MINUTE CRANK TIMER
VANEE 60H+ ERV	PLATINUM, DECO-TOUCH, LITE-TOUCH BRONZE, SIMPLE-TOUCH BRONZE OR BRONZE	

6. This unit must be grounded. The power supply cord has a 3-prong grounding plug for your personal safety. It must be plugged into a mating 3-prong grounding receptacle, grounded in accordance with the national electrical code and local codes and ordinances. Do not remove the ground prong. Do not use an extension cord.
7. Do not install in a cooking area or connect directly to any appliances.
8. Do not use to exhaust hazardous or explosive materials and vapors.
9. When performing installation, servicing or cleaning these units, it is recommended to wear safety glasses and gloves.
10. Due to the weight of the unit, two installers are recommended to perform installation.
11. When applicable local regulation comprise more restrictive installation and/or certification requirements, the aforementioned requirements prevail on those of this document and the installer agrees to conform to these at his own expenses.

### CAUTION

1. To avoid premature clogged filters, turn OFF the unit during construction or renovation.
2. Please read specification label on product for further information and requirements.
3. Be sure to duct air outside – Do not intake/exhaust air into spaces within walls or ceiling or into attics, crawl spaces, or garage.
4. Intended for residential installation only in accordance with the requirements of NFPA 90B (for a unit installed in U.S.A.) or Part 9 of the National Building Code of Canada (for a unit installed in Canada).
5. Do not run any air ducts directly above or closer than 2 ft (0.61 m) to any furnace or its supply plenum, boiler, or other heat producing appliance. If a duct has to be connected to the furnace return plenum, it must be connected not closer than 9' 10" (3 m) from this plenum connection to the furnace.
6. The ductwork is intended to be installed in compliance with all local and national codes that are applicable.
7. When leaving the house for a long period of time (more than two weeks), a responsible person should regularly check if the unit operates adequately.
8. If the ductwork passes through an unconditioned space (e.g.: attic), the unit must operate continuously except when performing maintenance and/or repair. Also, the ambient temperature of the house should never drop below 18°C (65°F).

---

---

# TABLE OF CONTENTS

---

---

1. TYPICAL INSTALLATIONS .....	4-5
1.1 FULLY DUCTED SYSTEM.....	4
1.2 CENTRAL DRAW POINT .....	4
1.3 SIMPLIFIED INSTALLATION .....	4
1.4 ATTIC INSTALLATION .....	5
2. INSTALLATION.....	5-10
2.1 INSPECT THE CONTENT OF THE BOX .....	5
2.2 LOCATING THE UNIT .....	5
2.3 UNIT PREPARATION .....	5-6
2.4 HOW TO HANG THE UNIT.....	6
2.5 PLANNING OF THE DUCTWORK .....	7
2.6 INSTALLING THE DUCTWORK AND REGISTERS .....	7-8
2.6.1 FULLY DUCTED SYSTEM .....	7
2.6.2 CENTRAL DRAW POINT SYSTEM .....	7
2.6.3 SIMPLIFIED INSTALLATION .....	8
2.7 CONNECTING THE DUCTS TO THE UNIT.....	9
2.8 INSTALLING 2 EXTERIOR HOODS.....	10
2.9 INSTALLING THE TANDEM® TRANSITION KIT .....	10
3. CONTROLS.....	11-13
3.1 INTEGRATED CONTROL.....	11
3.2 ELECTRICAL CONNECTION TO OPTIONAL WALL CONTROLS.....	12-13
3.2.1 ELECTRICAL CONNECTION TO ALTITUDE OR PLATINUM MAIN WALL CONTROL .....	12
3.2.2 ELECTRICAL CONNECTION TO DECO-TOUCH MAIN WALL CONTROL.....	12
3.2.3 ELECTRICAL CONNECTION TO LITE-TOUCH CONSTRUCTO OR BRONZE OR SIMPLE-TOUCH CONSTRUCTO OR BRONZE MAIN WALL CONTROLS .....	12
3.2.4 ELECTRICAL CONNECTION TO CONSTRUCTO OR BRONZE MAIN WALL CONTROL .....	12
3.2.5 ELECTRICAL CONNECTION TO OPTIONAL AUXILIARY WALL CONTROLS.....	13
4. ELECTRICAL CONNECTION TO THE FURNACE .....	13
5. WIRING DIAGRAM .....	14
6. BALANCING THE UNIT .....	15
7. SERVICE PARTS.....	16
8. TROUBLESHOOTING .....	17-18

# 1. TYPICAL INSTALLATIONS

Installations may vary according to the type of unit and the ports configuration (top or sides). Use the following illustrations as guidelines to help you decide on how the unit will be installed.

All the units should be hung from the joists.

In every case, bathroom fans and a range hood should be used to exhaust stale air. Also, for homes with more than one level, we recommend one exhaust register at the highest level.

There are 3 installation methods: Fully ducted, Central Draw Point and Simplified Installation.

NOTE: An electrical outlet has to be available within 3 feet of the unit.

## 1.1 FULLY DUCTED SYSTEM (PRIMARYLY FOR HOMES WITH RADIANT HOT WATER OR ELECTRIC BASEBOARD HEATING)

Stale air coming from the registers located at the highest level of the house is exhausted to the outside. Fresh air from outside is filtered and supplied by the register located in the lowest liveable level. Homes with more than one level require at least one exhaust register at the highest level. See figure at right.

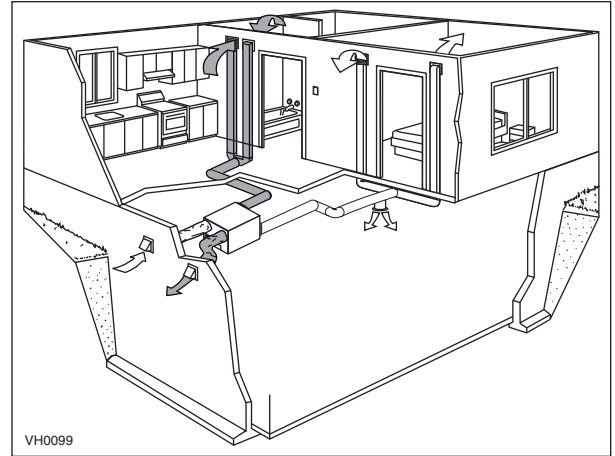

## 1.2 CENTRAL DRAW POINT (CONNECTION TO A FORCED AIR SYSTEM)

Stale air coming from the registers located at the highest level of the house is exhausted to the outside. Fresh air from outside is filtered and supplied to the return (plenum) or the supply duct of the forced air unit. See figure at right. For this type of installation, it is not essential that the forced air system blower runs when the unit is in operation, but we recommend it. NOTE: Home with multiple forced air systems should have one unit on each system.

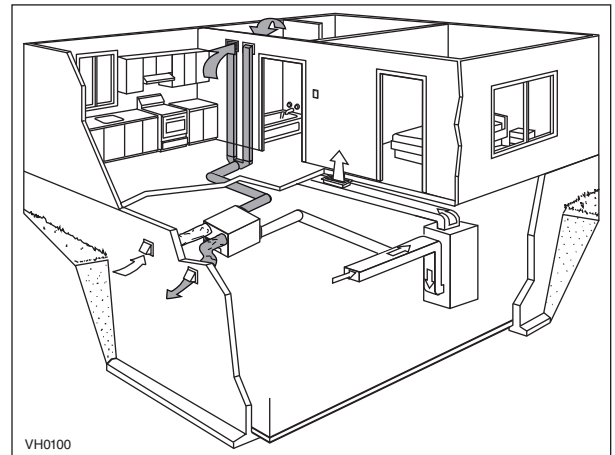

## 1.3 SIMPLIFIED INSTALLATION (CONNECTION TO A FORCED AIR SYSTEM)

Stale air is exhausted to the outside. Fresh air from outside is filtered and supplied to the return (plenum) or the supply duct of the forced air unit. See figure at right. To avoid cross-contamination and achieve the highest efficiencies, the forced air system blower must always be ON. NOTE: Home with multiple forced air systems should have one unit on each system.

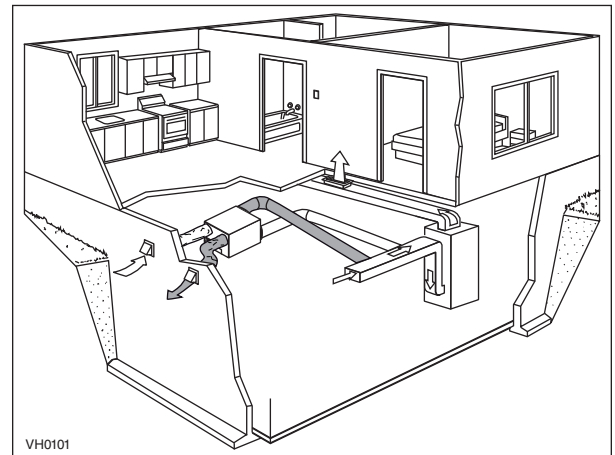

# 1. TYPICAL INSTALLATIONS (CONT'D)

## 1.4 ATTIC INSTALLATION

All 3 types of installations can be used in the attic (Fully ducted system, Central Draw Point or Simplified). The example shown below is a Simplified installation (connection to a forced air system).

NOTE: To get the most of your ERV unit, the ambient temperature around the unit should be conditioned. If the unit has to be installed in an unconditioned space, the heat gains or losses from the unit and the ducts could increase the operation costs of the unit.

**CAUTION**

- Due to the potential temperature difference between the attic and the rest of the house, all unit ducts must be insulated.
- The attic temperature must always be above 0°C (32°F) and under 65°C (149°F).

Stale air is exhausted to the outside. Fresh air from outside is filtered and supplied to the return (plenum) of the forced air unit. See figure at right.

To avoid cross-contamination and achieve the highest efficiencies, the forced air system blower must always be ON.

NOTE: Home with multiple forced air systems should have 1 unit on each system.

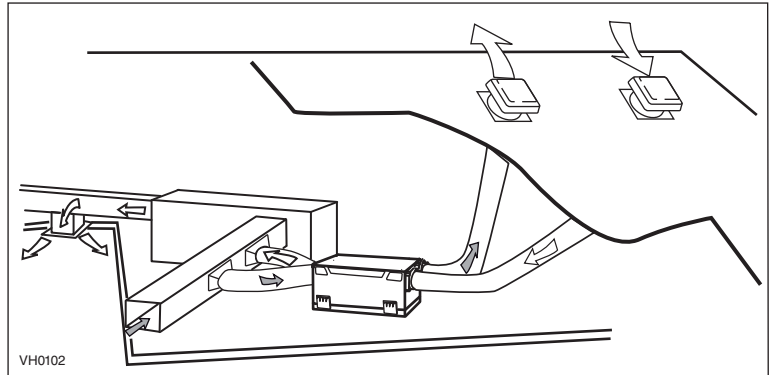

## 2. INSTALLATION

### 2.1 INSPECT THE CONTENTS OF THE BOX

- Inspect the exterior of the unit for shipping damage. Ensure that there is no damage to the door, door latches, power cord, etc.
- Remove and discard both transport brackets (A) and open the door. Discard the styrofoam fillers and remove the hardware kit from the unit. Inspect the interior of the unit for damage. Ensure that heat or energy recovery core, core filters, insulation, dampers, etc. are all intact.

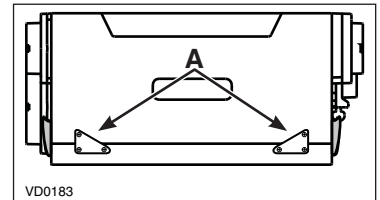

### 2.2 LOCATING THE UNIT

Choose an appropriate location for the unit.

- Within an area of the house where the ambient temperature is kept between 18°C (65°F) and 40°C (104°F).
- So as to provide easy access to the interior of the unit, for semi-annual and annual maintenance.
- Close to an exterior wall, so as to limit the length of the insulated flexible duct to and from the unit.
- Away from hot chimneys and other fire hazards.
- Allow for a power source (standard 3-prong grounding outlet).

### 2.3 UNIT PREPARATION

All these units are equipped with 2 ports having integrated balancing damper. Turn the thumb screw (B) clockwise to manually open and adjust the damper (C). Set both Fresh air to building port and Exhaust air to outside port to wide open position.

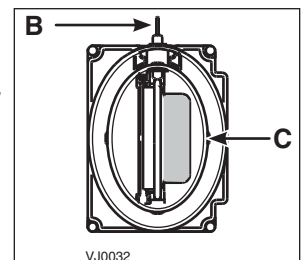

Port with integrated balancing damper - Top view

## 2. INSTALLATION (CONT'D)

### 2.3 UNIT PREPARATION (CONT'D)

The door latches location can be changed from sides to front of the unit, according to the installation needs.

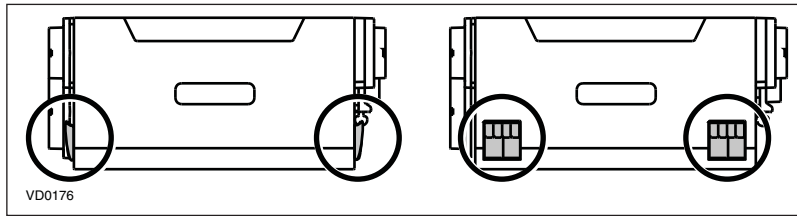

*Latches on sides of the unit*

*Latches in front of the unit*

To do so, turn the unit upside down. Open the latches and unscrew them from the unit. Install the latches on their new locations.

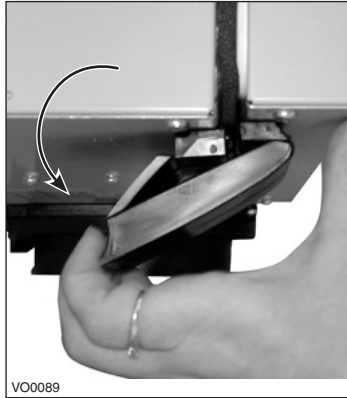

VO0089



VO0090

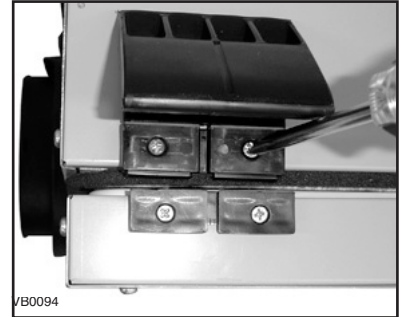

VB0094

### 2.4 HOW TO HANG THE UNIT

Hang the unit with the 4 chains, hooks and springs provided.

**CAUTION**  
Make sure the unit is level.

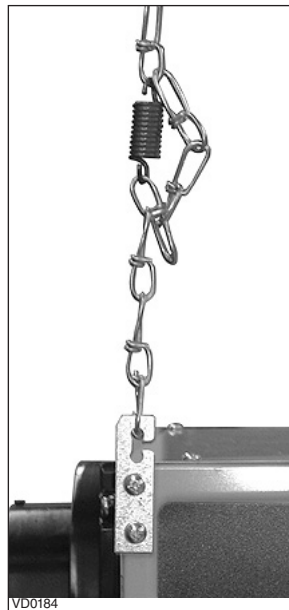

VD0184

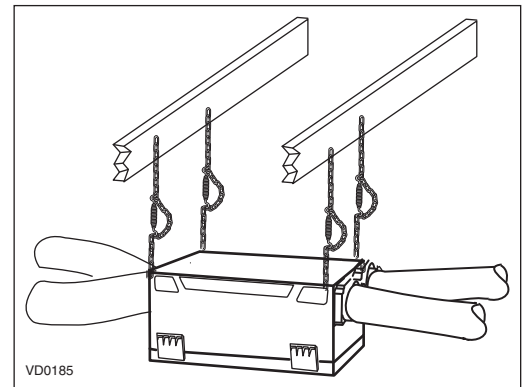

VD0185

If there is not enough space on top of the unit, slightly bend the hooks and install them lower on the unit. See figure at right.

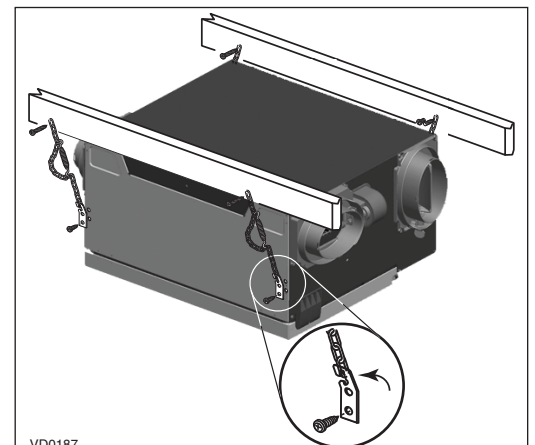

VD0187

## 2. INSTALLATION (CONT'D)

### 2.5 PLANNING OF THE DUCTWORK

- Keep it simple. Plan for a minimum of bends and joints.
- Keep the length of insulated ducts to a minimum.
- Do not ventilate crawl spaces or cold rooms. Do not attempt to recover the exhaust air from a dryer or a range hood. This would cause clogging of the filters and recovery module.
- If the house has two floors or more, be sure to plan for at least one exhaust register on the highest lived-in level.

### 2.6 INSTALLING THE DUCTWORK AND REGISTERS

#### ⚠ WARNING

**Never install a stale air exhaust register in a closed room where a combustion device operates, such as a gas furnace, a gas water heater or a fireplace.**

#### 2.6.1 FULLY DUCTED SYSTEM (AS ILLUSTRATED IN SECTION 1.1)

##### Stale air exhaust ductwork:

- Install the stale air exhaust registers where the contaminants are produced: Kitchen, living room, etc. Position the registers as far from the stairway as possible and in such a way that the air circulates in all the lived-in spaces in the house.
- If a register is installed in the kitchen, it must be located at least 4 feet (1.2 m) from the range.
- Install the registers 6 to 12 inches (152 to 305 mm) from the ceiling on an interior wall OR install them in the ceiling.

##### Fresh air distribution ductwork:

- Install the fresh air distribution registers in bedrooms, dining rooms, living room and basement.
- Keep in mind that the fresh air registers must be located as far as possible from the stale air registers.
- Install the registers in the ceiling OR 6 to 12 inches (152 to 305 mm) from the ceiling on an interior wall. The duct length should be at least 15' (4.6 m). (The fresh air will then flow through the room and mix with room air, ensuring a continuous renewed airflow.)
- If a register must be floor installed, direct the airflow up the wall.

#### 2.6.2 CENTRAL DRAW POINT SYSTEM (AS ILLUSTRATED IN SECTION 1.2)

##### Stale air exhaust ductwork:

Same as for Fully Ducted System, described on point 2.6.1

##### Fresh air distribution ductwork:

#### ⚠ WARNING

**When performing duct connections, always use approved tools and materials. Respect all corresponding laws and safety regulations. Please refer to your local building code.**

#### CAUTION

**When performing duct connections to the furnace supply duct, this duct must be sized to support the additional airflow produced by the ERV. Also, use a steel duct.**

There are 2 methods for connecting the unit to the furnace/air handler:

##### Method 1: Supply side connection

- Cut an opening into the furnace supply duct at least 18 inches (0.5 m) from the furnace/air handler.
- Connect this opening to the **Fresh air to building** port of the ERV (use **steel duct**, see figure at right).
- Make sure the ERV duct forms an elbow inside the furnace/air handler ductwork.
- If desired, interlock (synchronize) the furnace/air handler blower operation (see Section 4).

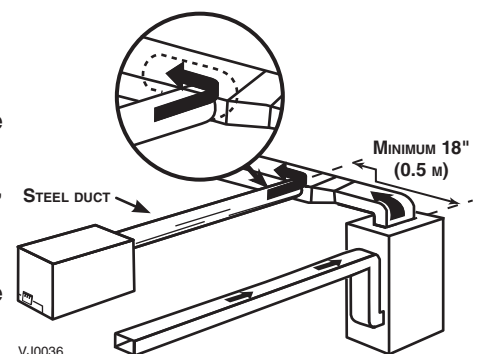

##### Method 2: Return side connection

- Cut an opening into the furnace return duct not less than 10 feet (3.1 m) from the furnace/air handler (A+B).
- Connect this opening to the **Fresh air to building** port of the ERV (see figure at right).

NOTE: For Method 2, it is not essential that the furnace/air handler runs when the unit is in operation, but we recommend it. If desired, interlock (synchronize) the furnace/air handler blower operation (see Section 4).

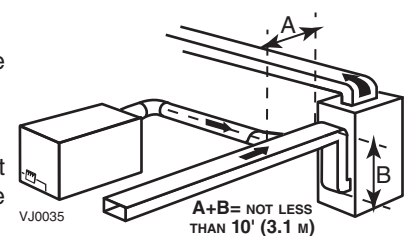

## 2. INSTALLATION (CONT'D)

### 2.6 INSTALLING THE DUCTWORK AND REGISTERS (CONT'D)

#### 2.6.3 SIMPLIFIED INSTALLATION (AS ILLUSTRATED IN SECTION 1.3)

#### ⚠ WARNING

When performing duct connections, always use approved tools and materials. Respect all corresponding laws and/or safety regulations. Please refer to your local building code.

#### CAUTION

When performing duct connections to the furnace supply duct, this duct must be sized to support the additional airflow produced by the ERV. Also, use a steel duct. For a Return-Return installation, the furnace blower must be in operation when the ERV is in operation.

There are 2 methods for connecting the unit to the furnace/air handler:

#### Method 1: Supply-return connection

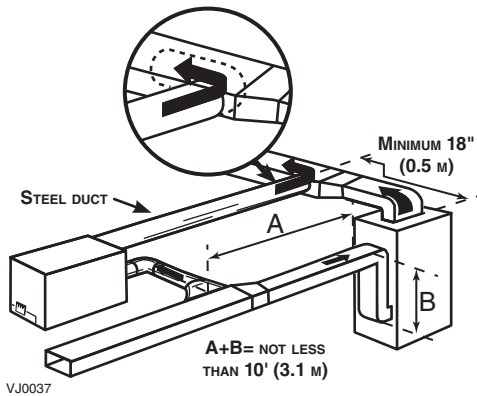

#### Method 2: Return-return without

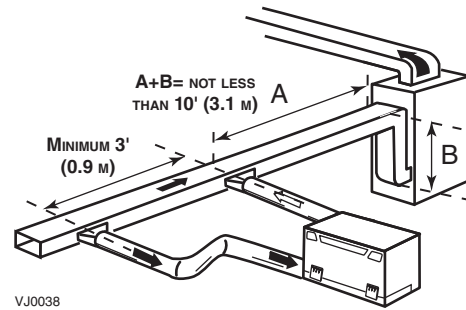

#### Stale air intake:

- Cut an opening into the furnace/air handler return duct not less than 10 feet (3.1 m) from the furnace/air handler (A+B).
- Connect this opening to the **Exhaust air from building** port of the ERV.

#### Fresh air distribution:

- Same instructions as for Method 1 or Method 2, Section 2.6.2.

For Method 2 (Return-return), make sure there is a distance of at least 3 feet (0.9 m) between the 2 connections to the furnace/air handler.

NOTE: For Method 1, it is not essential to synchronize the furnace blower operation with the unit operation, but we recommend it.

#### CAUTION

If using Method 2, make sure the furnace/air handler blower operation is synchronized with the unit operation! See Section 4.



## 2. INSTALLATION (CONT'D)

### 2.7 CONNECTING THE DUCTS TO THE UNIT

NOTE: All units ports were created to be connected to ducts having a minimum of 5" diameter, but if need be, they can be connected to bigger sized ducts by using an appropriate transition (e.g.: 5" diameter to 6" diameter transition).

#### Insulated flexible ducts:

#### CAUTION

Make sure the balancing dampers are set to wide open position before connecting the ducts to the ports.

All units have both Fresh air to building and Exhaust air to outside ports equipped with integrated balancing damper. Prior to install the insulated flexible ducts on, ensure these both ports have their dampers set to wide open position (See Section 2.3)

#### CAUTION

If ducts have to go through an unconditioned space (e.g.: attic), always use insulated ducts.

Use the following procedure for connecting the insulated flexible ducts to the port of the unit (**Exhaust air to outside** and **Fresh air from outside** ports).

- 1 Pull back the insulation to expose the flexible duct.
- 2 Attach the flexible duct to the port using tie wrap.
- 3 Pull the insulation over the joint and tuck in between the inner and outer rings of the double collar, then pull down the vapor barrier (shaded part in illustrations below) over the insulation and over the outer ring of double collar.
- 4 Apply duct tape to the joint making an airtight seal. Avoid compressing the insulation when pulling the tape tightly around the joint. Compressed insulation loses its R value and causes water dripping due to condensation on the exterior surface of the duct.

#### CAUTION

Make sure the vapor barrier on the insulated ducts does not tear during installation to avoid condensation within the ducts.

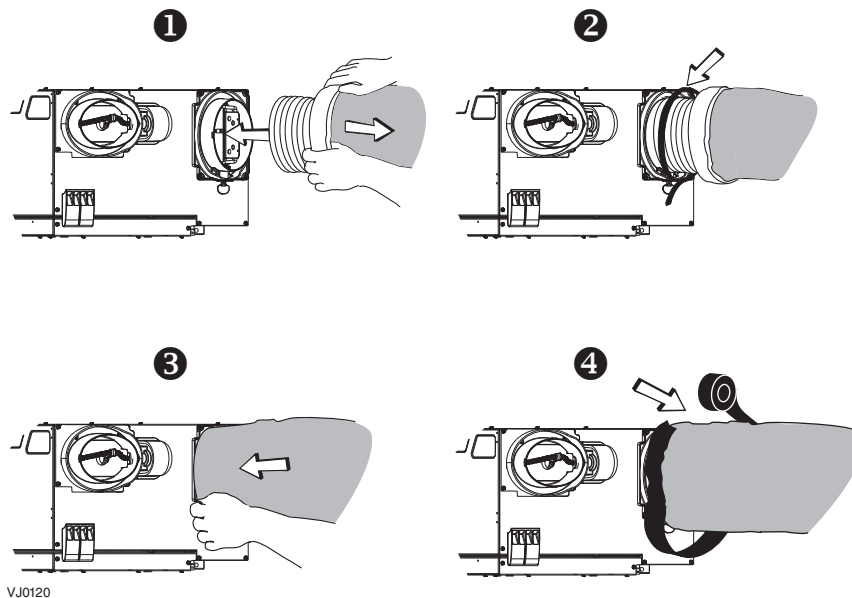

#### Rigid ducts:

#### CAUTION

Do not use screws to connect the rigid ducts to the ports.

Use a small length (6" length) of flexible duct to connect the rigid duct to the ports in order to avoid vibration transmissions. Use tie-wraps to perform connections, then seal with duct tape.

## 2. INSTALLATION (CONT'D)

### 2.8 INSTALLING 2 EXTERIOR HOODS

Choose an appropriate location to install the exterior hoods:

- There must be a minimum distance of 6' (1.8 m) between the hoods to avoid cross-contamination
- There must be a minimum distance of 18" (457 mm) from the ground

#### ⚠ WARNING

Make sure the intake hood is at least 6 feet (1.8 m) away from any of the following:

- Dryer exhaust, high efficiency furnace vent, central vacuum vent
- Gas meter exhaust, gas barbecue-grill
- Any exhaust from a combustion source
- Garbage bin and any other source of contamination

Refer to figure below for connecting insulated ducts to the exterior hoods. An "Anti-gust intake hood" should be installed in regions where a lot of snow is expected to fall.

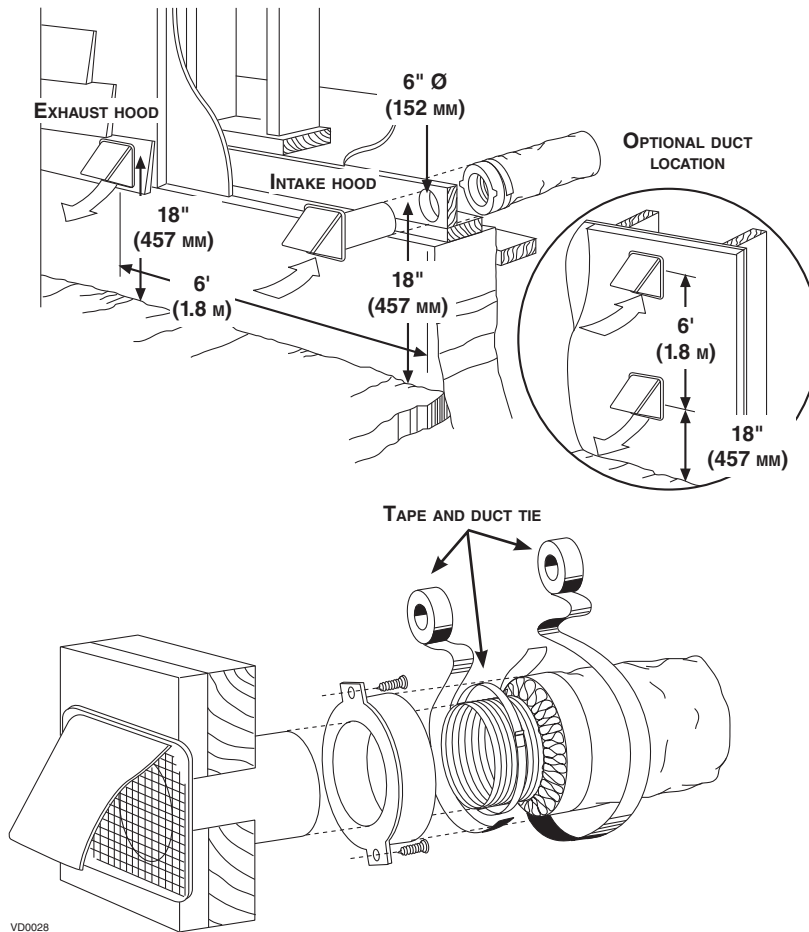

### 2.9 INSTALLING THE TANDEM® TRANSITION\* KIT

If desired, a Tandem transition kit can be used instead of 2 exterior hoods; but take in account this device will generate additional 0.23 in. w.g. static pressure.

The joist opening needed to install the Tandem® transition must be 9¾" minimum. The maximum height of the Tandem transition is 8¾".

To connect the insulated flexible ducts to the Tandem transition (*Exhaust air to outside* and *Fresh air from outside*), follow the instructions included with the Tandem transition kit (part no.14690).

\*Patented.

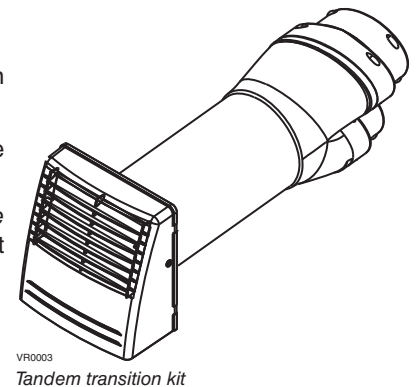

### 3. CONTROLS

#### 3.1 INTEGRATED CONTROL

All units are equipped with an integrated control, located under the unit, in front of the electrical compartment. Use the push button (1) to control the unit. The LED (2) will then shows on which mode the unit is in.

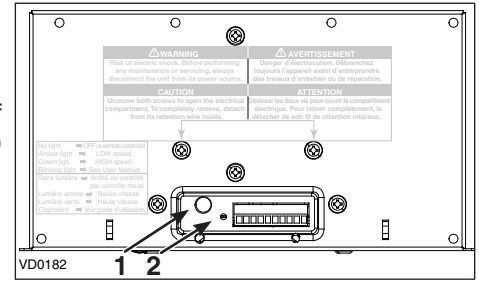

Refer to table at right to see how to operate the unit using its integrated control.

PRESS ON PUSH BUTTON	LED COLOR	RESULTS
ONCE	AMBER	UNIT IS ON LOW SPEED
TWICE	GREEN	UNIT IS ON HIGH SPEED
THREE TIMES	No LIGHT	UNIT IS OFF

If a problem occurs during the unit operation, its integrated control LED (2) will blink. The color of the blinking light depends on the type of error detected. Refer to Section 8 TROUBLESHOOTING on page 17 for further details.

##### 3.1.1 BOOT SEQUENCE

The unit boot sequence is similar to a personal computer boot sequence. Each time the unit is plugged after being unplugged, or after a power failure, the unit will perform a 30-second booting sequence before starting to operate. During the booting sequence, the integrated control LED will light GREEN or AMBER for 5 seconds, and then will shut off for 2 seconds. After that, the LED will light RED for the rest of the booting sequence. During this RED light phase, the unit is checking and resetting the motorized damper position. Once the motorized damper position completely set, the RED light turns off and the booting sequence is done.

NOTE: No command will be taken until the unit is fully booted.

##### 3.1.2 SETTING EXTENDED DEFROST

These units are factory set to normal defrost. In cold region (outside temperature  $-27^{\circ}\text{C}$  [ $-17^{\circ}\text{F}$ ] and lower), it may be necessary to setup extended defrost. During the first 2 seconds of booting sequence, while the integrated control LED is GREEN, press on push button for 3 seconds to set the unit in extended defrost; the LED will blink AMBER to show the unit is in extended defrost mode. After that, the LED will shut off, then light RED (the unit returns in its booting sequence).

### 3. CONTROLS (CONT'D)

#### 3.2 ELECTRICAL CONNECTION TO OPTIONAL WALL CONTROLS

For more convenience, this unit can also be controlled using an optional main wall control.

NOTES: 1. The integrated control must be turned OFF to use an optional main control.

2. If an optional auxiliary control is used, if activated, this auxiliary control will override the optional main control operation.

#### ⚠ WARNING

**Always disconnect the unit before making any connections. Failure in disconnecting power could result in electric shock or damage of the wall control or electronic module inside the unit.**

#### CAUTION

**Never install more than one main wall control per unit. Make sure that the wires do not short-circuit between themselves or by touching any other components on the wall control. Avoid poor wiring connections. To reduce electrical interference (noise) potential, do not run wall control wiring next to control contactors or near light dimming circuits, electrical motors, dwelling/building power or lighting wiring, or power distribution panel.**

Use the terminal connector included in the installation kit to perform the electrical connection for main and optional wall controls. Check if all wires are correctly inserted in their corresponding holes in the terminal block. (A wire is correctly inserted when its orange receptacle is lower than another one without wire. On illustration at right, wire **A** is correctly inserted, but not wire **B**.)

Splice back the end of the cable to access the 4 wires. Strip the end of each wire. Connect each wire to its corresponding terminal: YELLOW wire to "Y", RED wire to "R", GREEN wire to "G" and BLACK wire to "B". Check if all wires are correctly inserted in their corresponding holes in the terminal block.

Connect the auxiliary control cable, if installed (not shown).

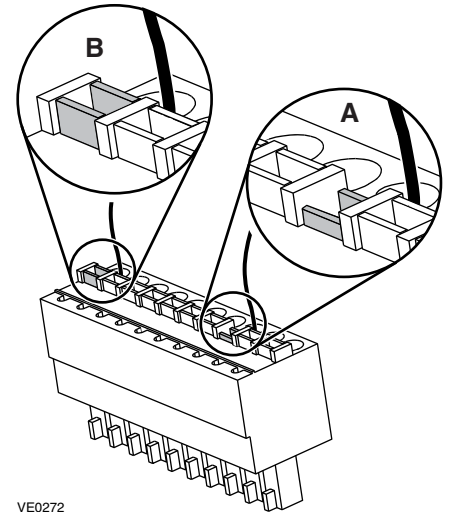

VE0272

#### 3.2.1 ELECTRICAL CONNECTION TO ALTITUDE OR PLATINUM MAIN WALL CONTROL

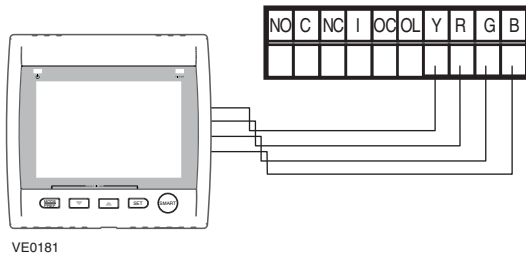

VE0181

#### 3.2.2 ELECTRICAL CONNECTION TO DECO-TOUCH MAIN WALL CONTROL

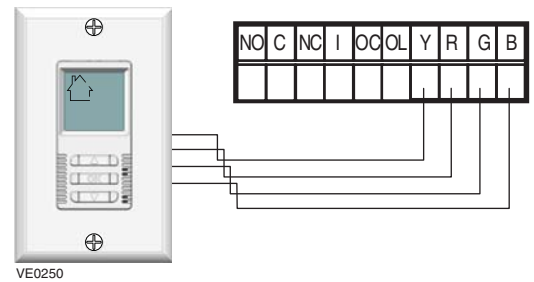

VE0250

#### 3.2.3 ELECTRICAL CONNECTION TO LITE-TOUCH CONSTRUCTO OR BRONZE, OR SIMPLE-TOUCH CONSTRUCTO OR BRONZE MAIN WALL CONTROLS

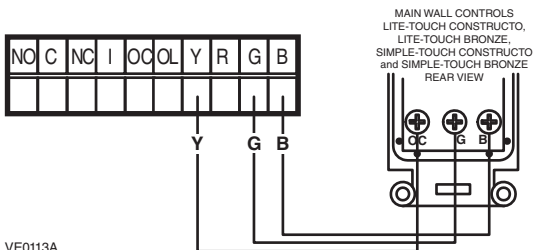

VE0113A

#### 3.2.4 ELECTRICAL CONNECTION TO CONSTRUCTO OR BRONZE MAIN WALL CONTROL

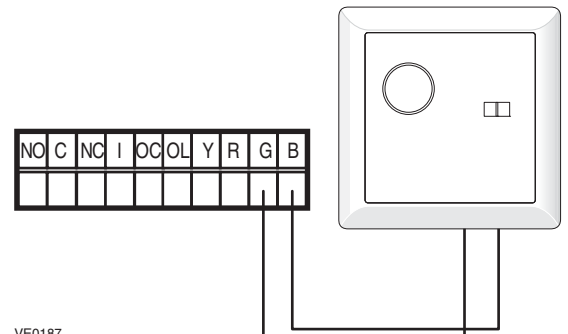

VE0187

### 3. CONTROLS (CONT'D)

#### 3.2 ELECTRICAL CONNECTION TO OPTIONAL WALL CONTROLS (CONT'D)

##### 3.2.5 ELECTRICAL CONNECTION TO OPTIONAL AUXILIARY WALL CONTROLS

NOTE: If an optional auxiliary wall control is activated and then, the Dehumidistat is being activated, this one will override the auxiliary wall control commands.

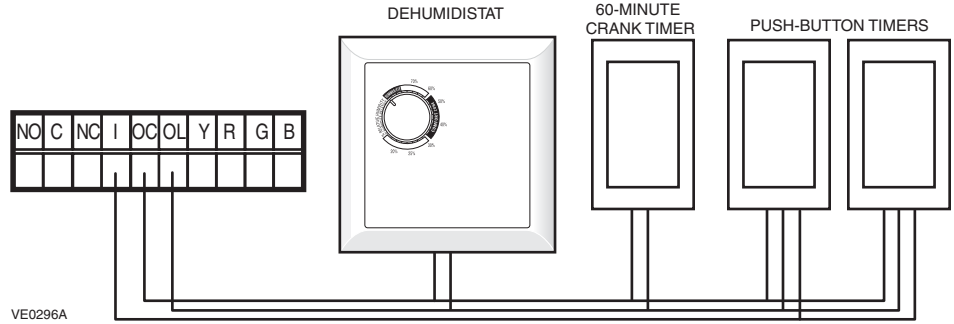

Once the wall control(s) connections have been made, insert the terminal connector in the bottom of the unit, on the electrical compartment front face.

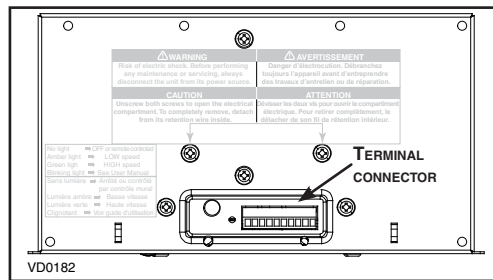

NOTE: For information about the operation of the wall controls, refer to the user guide.

### 4. ELECTRICAL CONNECTION TO THE FURNACE

#### ⚠ WARNING

Never connect a 120-volt AC circuit to the terminals of the furnace interlock (standard wiring). Only use the low voltage class 2 circuit of the furnace blower control.

For a furnace connected to a cooling system:

On some older thermostats, energizing the “R” and “G” terminals at the furnace has the effect of energizing “Y” at the thermostat and thereby turning on the cooling system. If you identify this type of thermostat, you must use the ALTERNATE FURNACE INTERLOCK WIRING.

#### STANDARD FURNACE INTERLOCK WIRING

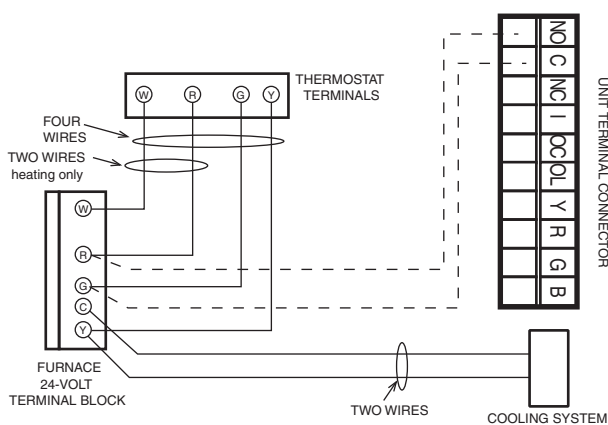

VE0108A

#### ALTERNATE FURNACE INTERLOCK WIRING

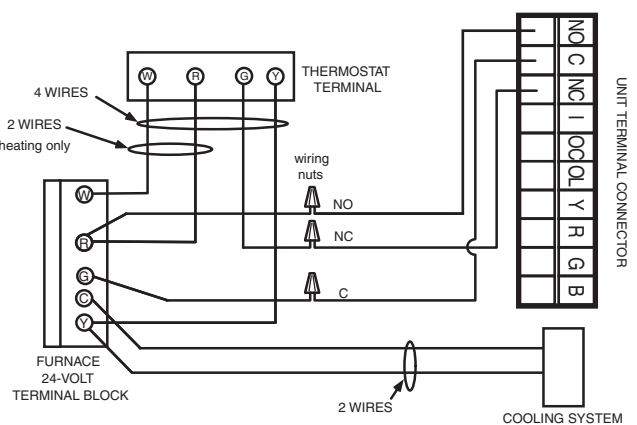

# 5. WIRING DIAGRAM

## ⚠ WARNING

- Risk of electric shocks. Before performing any maintenance or servicing, always disconnect the unit from its power source.
- This product is equipped with an overload protection (fuse). A blown fuse indicates an overload or a short-circuit situation. If the fuse blows, unplug the product and check the polarity and voltage output from the outlet. Replace the fuse as per the servicing instructions (refer to wiring diagram for proper fuse rating) and verify the product. If the replaced fuse blows, it may be a short-circuit and the product must be discarded or returned to an authorized service center for examination and/or repair.

LOGIC DIAGRAM

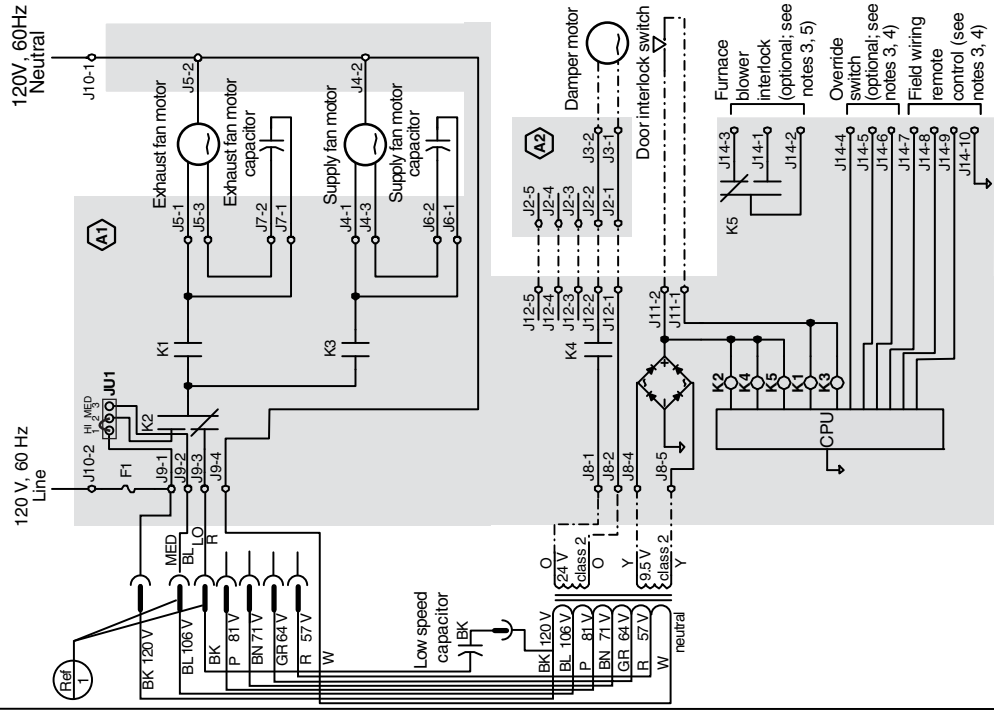

WIRING DIAGRAM

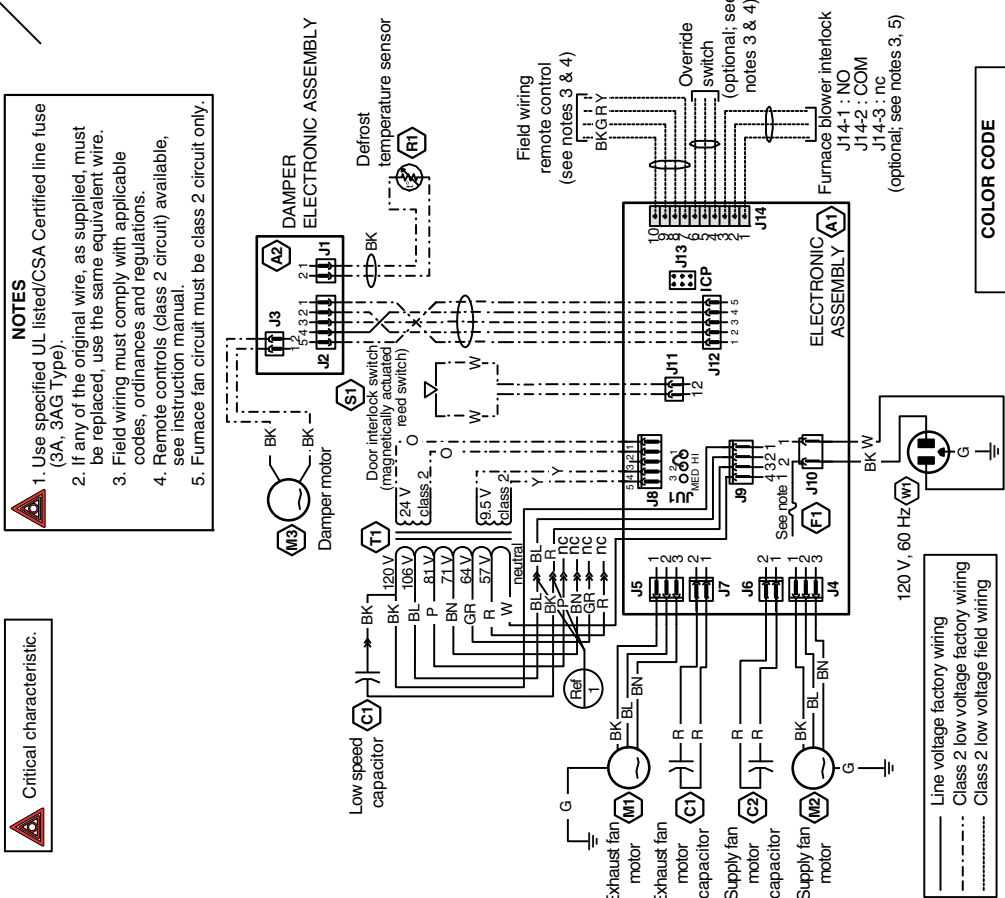

- NOTES**
1. Use specified UL listed/CSA Certified line fuse (3A, 3AG Type).
  2. If any of the original wire, as supplied, must be replaced, use the same equivalent wire.
  3. Field wiring must comply with applicable codes, ordinances and regulations.
  4. Remote controls (class 2 circuit) available, see instruction manual.
  5. Furnace fan circuit must be class 2 circuit only.

**⚠ Critical characteristic.**

**COLOR CODE**

BK	BLACK
BL	BLUE
BN	BROWN
G	GREEN
GR	GREY
O	ORANGE
P	PURPLE
R	RED
W	WHITE
Y	YELLOW
nc	no connection

**FAN MOTORS SPEED SELECTION**

SETTING	Ref 1	FAN SPEEDS (Voltage)
Factory shipped	BL → BL	Low - High (106)
Med-High select	BL → BL GR → BL	Med (64) - High (106)
Low-Med select	BL → BL GR → BL P → BL	Low - Med (81)

- Line voltage factory wiring
- - - Class 2 low voltage factory wiring
- ..... Class 2 low voltage field wiring

## 6. BALANCING THE UNIT

To avoid balancing, the difference between stale air ducts total length and fresh air ducts total length must not exceed 50 ft. However, even if the stale air ducts and fresh air ducts lengths are almost equal, your local building codes may require balancing the unit.

If the unit does not need to be balanced, shut all the pressure taps (located on the unit door) with the small plastic plugs included in the hardware kit.

### 6.1 WHAT YOU NEED TO BALANCE THE UNIT

- A magnehelic gauge capable of measuring 0 to 0.5 inch of water (0 to 125 Pa) and 2 plastic tubes.
- The balancing chart located on the unit door.

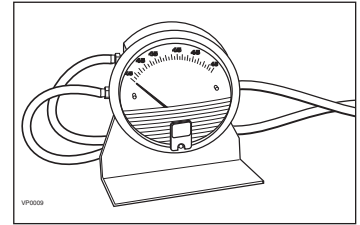

### 6.2 PRELIMINARY STAGES TO BALANCE THE UNIT

- Seal all the unit ductwork with tape. Close all windows and doors.
- Turn off all exhaust devices such as range hood, dryer and bathroom fans.
- Make sure the integrated balancing dampers are fully open. Turn the thumb screw (A) **clockwise** to manually open the dampers. Both are located on the Exhaust air to outside port and on Fresh air to building port.
- Make sure all filters are clean (if it is not the first time you balance the unit).

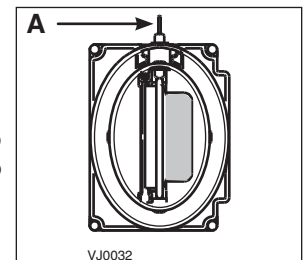

Port with integrated balancing damper - Top view

### 6.3 BALANCING PROCEDURE

#### 1. Set the unit to high speed.

Make sure that the furnace/air handler blower is ON if the installation is in any way connected to the ductwork of the cold air return. If not, leave furnace/air handler blower OFF. If the outside temperature is below 0°C/32°F, make sure the unit is not running in defrost while balancing. (By waiting 10 minutes after plugging the unit in, you are assured that the unit is not in a defrost cycle.)

#### 2. Place the magnehelic gauge on a level surface and adjust it to zero.

#### 3. Connect tubing from gauge to exhaust air flow pressure taps (see diagram at right).

Be sure to connect the tubes to their appropriate high/low fittings. If the gauge drops below zero, reverse the tubing connections.

NOTE: It is suggested to start with the exhaust air flow reading because the exhaust has typically more restriction than the fresh air, especially in cases of fully ducted installations or source point ventilation. Place the magnehelic gauge upright and level. Record equivalent air flow of the reading according to the balancing chart.

#### 4. Move tubing to fresh air flow pressure taps (see diagram). Adjust the fresh air balancing damper until the fresh air flow is approximately the same as the exhaust air flow. If fresh air flow is less than exhaust air flow, then go back and adjust the exhaust balancing damper to equal the fresh air flow.

#### 5. Secure both dampers thumb screw in place with tape.

#### 6. Write the required air flow information on a label and stick it near the unit for future reference (date, maximum speed air flows, your name, phone number and business address).

NOTE: The unit is considered balanced even if there is a difference of  $\pm 10$  cfm (or  $\pm 5$  l/s or 17 m<sup>3</sup>/h) between the two air flows.

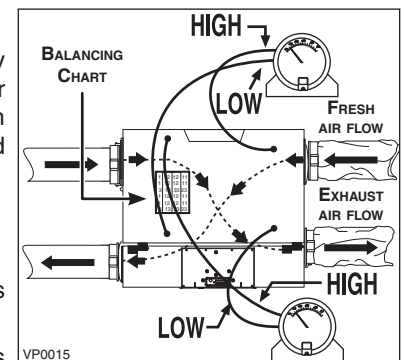

## 7. SERVICE PARTS

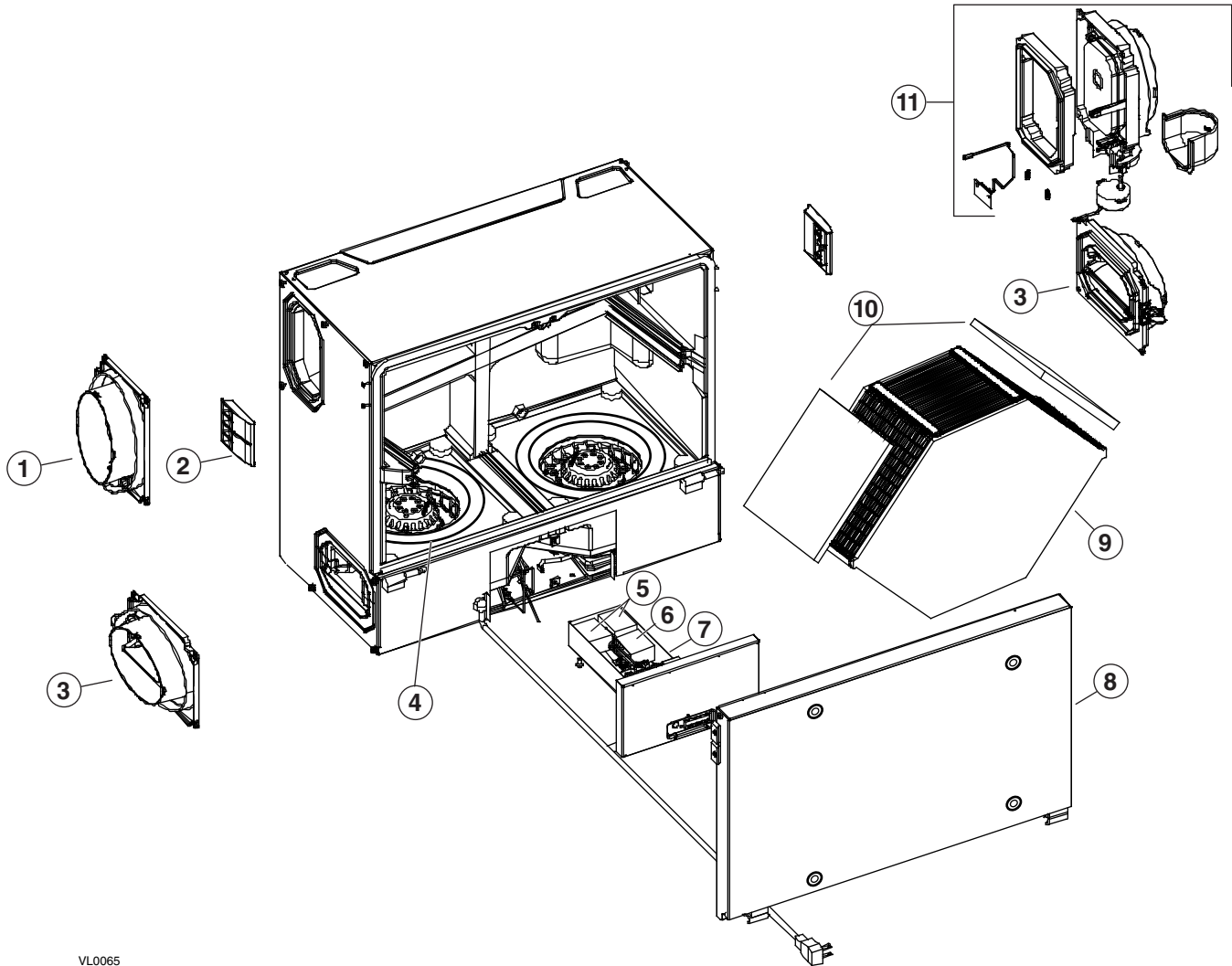

VL0065

### REPLACEMENT PARTS AND REPAIR

In order to ensure your ventilation unit remains in good working condition, you must use the manufacturer genuine replacement parts only. The manufacturer genuine replacement parts are specially designed for each unit and are manufactured to comply with all the applicable certification standards and maintain a high standard of safety. Any third party replacement part used may cause serious damage and drastically reduce the performance level of your unit, which will result in premature failing. Also, the manufacturer recommends to contact a certified service depot for all replacement parts and repairs.

No.	DESCRIPTION	PART No.	41554 ERV SIDE PORTS	41556 ERV TOP PORTS	41654 ERV SIDE PORTS	41656 ERV TOP PORTS
1	OVAL PORT (FITS 5" DIAMETER DUCTS)	16040	1	1	1	1
2	DOOR LATCH WITH SCREWS	16035	2	2	2	2
3	OVAL PORT WITH INTEGRATED BALANCING DAMPER	16041	2	2	2	2
4	MOTOR & WHEEL ASSEMBLY (5 $\mu$ F MOTOR CAPACITOR AND INLET RING INCLUDED)	18301	2	2	2	2
5	CAPACITOR 5 $\mu$ F (2)	16042	1	1	1	1
6	CAPACITOR 18 $\mu$ F	61127	1	1	1	1
7	ELECTRONIC BOARD	62257	1	1	1	1
8	DOOR ASSEMBLY	16094	1	1		
		16095			1	1
9	ERV CORE (WITH 2 FILTERS)	16033	1	1	1	1
10	ERV FOAM FILTER	16031	2	2	2	2
11	MOTORIZED DAMPER PORT ASSEMBLY	16029	1	1	1	1
*	ES TRANSFORMER	18302	1	1	1	1
*	PCB CONNECTOR	16416	1	1	1	1

\* NOT SHOWN.



## 8. TROUBLESHOOTING

If the unit does not work properly, reset the unit by unplugging it for one minute and then replug it. If it still not working properly, refer to table below.

If the integrated control LED of the unit is flashing, this means the unit sensors detected a problem. See the table below to know where the problem occurs on the unit.			
LED SIGNAL	ERROR TYPE	ACTION	UNIT STATUS
LED flashes GREEN	Thermistor error	Replace the entire port assembly (fresh air from outside port)	Unit works but will defrost frequently
LED flashes AMBER	Damper error	Go to point 7	Unit does not work
LED flashes RED	<ul style="list-style-type: none"> <li>The door is open and the unit is not unplugged</li> <li>Exhaust motor error</li> </ul>	<ul style="list-style-type: none"> <li>Put a magnet over the door switch or close the door and press once on the integrated control push button to reset the unit.</li> <li>Go to 8</li> </ul>	Unit does not work

	PROBLEMS	POSSIBLE CAUSES	YOU SHOULD TRY THIS
1	The error code E1 is displayed on Altitude, Platinum or Deco-Touch wall control screen.	<ul style="list-style-type: none"> <li>Unit not compatible with control.</li> <li>The wires may be in reverse position.</li> <li>The wires may be misconnected.</li> <li>The wires may be broken.</li> </ul>	<ul style="list-style-type: none"> <li>Check table on page 2 for control compatibility.</li> <li>Ensure that the color coded wires have been connected to their appropriate places.</li> <li>Ensure the wires are correctly connected.</li> <li>Inspect every wire and replace any that is damaged. If wires are hidden into walls, test the control using a shorter wire.</li> </ul>
2	There is no outside temperature displayed on Altitude or Platinum wall control screen <b>— —</b> .	<ul style="list-style-type: none"> <li>RED wire in control cable damaged or misconnected.</li> </ul>	<p>NOTE: At its very start-up or after a power failure, it takes some minutes before the outside temperature appears on screen. The delay duration depends on which operation mode the wall control is set. The shortest delay is obtained when the wall control is set on MIN or MAX in VENT Mode.</p> <ul style="list-style-type: none"> <li>Ensure the RED wire is not damaged and properly connected.</li> </ul>
3	Altitude, Platinum or Deco-Touch wall control screen alternates between normal display and E3.	<ul style="list-style-type: none"> <li>The Altitude, Platinum or Deco-Touch wall control may be defective.</li> </ul>	<ul style="list-style-type: none"> <li>Replace the Altitude, Platinum or Deco-Touch wall control.</li> </ul>
4	The wall control does not work.	<ul style="list-style-type: none"> <li>Unit integrated control set to low or high speed (AMBER or GREEN continuous LED).</li> <li>Unit not compatible with control.</li> <li>The wires may be in reverse position.</li> <li>The wires may be misconnected.</li> <li>The wires may be broken.</li> <li>Defective wall control.</li> </ul>	<ul style="list-style-type: none"> <li>Press on the integrated push button until the LED turns off.</li> <li>Check table on page 2 for control compatibility.</li> <li>Ensure that the color coded wires have been connected to their appropriate places.</li> <li>Ensure the wires are correctly connected.</li> <li>Inspect every wire and replace any that are damaged.</li> <li>Replace the wall control.</li> </ul>
5	Unit does not work (LED not lit on power up).	<ul style="list-style-type: none"> <li>Unit is unplugged.</li> <li>No power to power outlet.</li> <li>The fuse may be defective.</li> <li>J10, J9, or J8 connector(s) may be unplugged.</li> <li>The transformer may be defective (no 9.5 VAC between J8-4 and J8-5).</li> <li>The PCB may be defective.</li> </ul>	<ul style="list-style-type: none"> <li>Make sure the unit is plugged.</li> <li>Test the power outlet with another electrical device (e.g.: a lamp). If it does not work, call an electrician.</li> <li>Check if fuse F1 (located on the PCB) is blown. In that case, replace fuse F1 as per product nameplate.</li> <li>Check the connection of J10, J9, and J8 connector(s).</li> <li>With unit powered and J9 connected, check if there is about 9.5 VAC between transformer connector J8-4 and J8-5 (YELLOW wires). If no, change the transformer.</li> <li>Unplug the unit. Disconnect the main control and the auxiliary control(s) (if need be). Jump <b>G</b> and <b>B</b> terminals. Plug the unit back and wait about 10 seconds. If the motors run on high speed and the damper opens, the circuit board is not defective.</li> </ul>

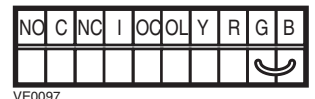

## 8. TROUBLESHOOTING (CONT'D)

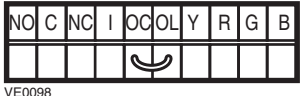
	PROBLEMS	POSSIBLE CAUSES	YOU SHOULD TRY THIS
6	The Dehumidistat OR other auxiliary control does not work.	<ul style="list-style-type: none"> <li>The wires may be in reverse position.</li> <li>The wires may be misconnected.</li> <li>The wires may be broken.</li> <li>The Dehumidistat or push button may be defective.</li> </ul>	<ul style="list-style-type: none"> <li>Ensure that the color coded wires have been connected to their appropriate places.</li> <li>Ensure the wires are correctly connected.</li> <li>Inspect every wire and replace any that is damaged. If wires are hidden into walls, test the control using a shorter wire.</li> <li>Jump the <b>OL</b> and <b>OC</b> terminals. If the unit switch to high speed, remove the Dehumidistat or push button and test it right beside the unit using another shorter wire. If it works here, change the wire. If it doesn't, change the Dehumidistat or the push button.</li> </ul> 
7	The damper system does not work (AMBER error code).	<b>At power up, no RED LED.</b>	<ul style="list-style-type: none"> <li>See point 5.</li> </ul>
		<b>At power up, LED lights RED and there is a clicking sound coming from electrical compartment, but damper does not move:</b> <ul style="list-style-type: none"> <li>Ice or other things hindering the damper movement.</li> <li>J12 unconnected or bad contact.</li> <li>Wrong connection of J8.</li> <li>The transformer may be defective (no 24 VAC between J8-1 and J8-2).</li> <li>The damper actuator may be defective.</li> </ul>	<ul style="list-style-type: none"> <li>Remove ice or hindering elements.</li> <li>Check J12 connection (both harness side and board side).</li> <li>Check J8 connection.</li> <li>With unit powered and J9 connected, check if there is about 20-24 VAC between transformer connector J8-1 and J8-2 (ORANGE wires). If no, change the transformer.</li> <li>Replace the damper system (entire port assembly).</li> </ul>
8	A. The supply motor does not work, but exhaust motor works.	<ul style="list-style-type: none"> <li>The supply motor may be defective.</li> <li>The supply motor capacitor or the PCB may be defective.</li> </ul>	<ul style="list-style-type: none"> <li>Plug supply motor to J5 connector and exhaust motor to J4 connector. If the integrated control LED flashes RED, the supply motor is defective. If exhaust motor works, plug back supply motor to J4 connector and exhaust motor to J5 connector, then check for supply motor capacitor validity.</li> <li>Plug supply motor capacitor to J7 connector and exhaust motor capacitor to J6 connector. If the integrated control LED flashes RED, the supply motor capacitor is defective. If there is no change, the PCB is defective.</li> </ul>
	B. The integrated control LED flashes RED.	<ul style="list-style-type: none"> <li>The exhaust motor may be defective.</li> <li>The exhaust motor capacitor may be defective.</li> <li>Transformer wire(s) bad connection.</li> <li>The transformer or the PCB may be defective.</li> </ul>	<ul style="list-style-type: none"> <li>Plug exhaust motor to J4 connector and supply motor to J5 connector. If supply motor works but exhaust motor does not, exhaust motor is defective. If exhaust motor works, plug back supply motor to J4 connector and exhaust motor to J5 connector, then check for exhaust motor capacitor validity.</li> <li>Plug exhaust motor capacitor to J6 connector and exhaust motor capacitor to J7 connector. If exhaust motor works but supply motor does not, the exhaust motor capacitor is defective. If there is no change, check validity of transformer or PCB.</li> <li>Check J8 and J9 connectors, as well as BLUE and RED wire connections from J9.</li> <li>Move JU1 jumper from pins 2 and 1 to pins 2 and 3. Set the unit on high speed. If exhaust motor works, the transformer is defective. If it still does not, change the PCB..</li> </ul>