

INSTALLER MANUAL



VB0175

HRV CONSTRUCTO 1.5ES*

(PART NOS 46110 AND 1601702)

HRV CONSTRUCTO 2.0ES*

(PART NO. 47110)



VB0176

HRV SOLO 1.5ES*

(PART NOS 46720 AND 46725)

HRV SOLO 2.0ES*

(PART NO. 47720)



* THESE PRODUCTS EARNED THE ENERGY STAR® BY MEETING STRICT ENERGY EFFICIENCY GUIDELINES SET BY NATURAL RESOURCES CANADA AND THE US EPA. THEY MEET ENERGY STAR REQUIREMENTS ONLY WHEN USED IN CANADA.



VB0170

ERV CONSTRUCTO 2.0ES

(PART NO. 47115)

IMPORTANT INFORMATION FOR THIS UNIT ABOUT DRAIN INSTALLATION IN COLD CLIMATES ON PAGE 12, SECTION 3.8.

RESIDENTIAL USE ONLY

READ AND SAVE THESE INSTRUCTIONS



20503 REV. 07

ABOUT THIS MANUAL

Because of the large amount of models covered by this publication, the illustrations are typical ones. Some details of your unit may be slightly different than the ones shown.

Please take note that this manual uses the following symbols to emphasize particular information:

⚠ WARNING

Identifies an instruction which, if not followed, might cause serious personal injuries including possibility of death.

CAUTION

Denotes an instruction which, if not followed, may severely damage the unit and/or its components.

NOTE: Indicates supplementary information needed to fully complete an instruction.

We welcome any suggestions you may have concerning this manual and/or the unit, and we would appreciate hearing your comments on ways to better serve you. Please contact us by phone at 1-800-567-3855.

ABOUT THESE UNITS

LIMITATION

For residential (domestic) installation only. Installation work and electrical wiring must be done by a qualified person(s) in accordance with all applicable codes and standards, including fire-rated construction codes and standards.

⚠ WARNING

TO REDUCE THE RISK OF FIRE, ELECTRIC SHOCK, OR INJURY TO PERSON(S) OBSERVE THE FOLLOWING:

1. Use this unit only in the manner intended by the manufacturer. If you have questions, contact the manufacturer at the address or telephone number listed in the warranty.
2. Before servicing or cleaning this unit, disconnect power cord from electrical outlet.
3. This unit is not designed to provide combustion and/or dilution air for fuel-burning appliances.
4. When cutting or drilling into wall or ceiling, do not damage electrical wiring and other hidden utilities.
5. Do not use this unit with any solid-state speed control device other than following:

Units	Optional Main Controls	Optional Auxiliary Controls
Constructo	Deco-Touch, Lite-Touch Constructo, Constructo	Dehumidistat, 20-min. lighted push-button, 60-min. mechanical timer
Solo	Altitude, Deco-Touch, Lite-Touch Constructo, Simple-Touch Constructo, Constructo	Dehumidistat, 20/40/60-min. lighted push-button, 60-min. mechanical timer

6. This unit must be grounded. The power supply cord has a 3-prong grounding plug for your personal safety. It must be plugged into a mating 3-prong grounding receptacle, grounded in accordance with the national electrical code and local codes and ordinances. Do not remove the ground prong. Do not use an extension cord.
7. Do not install in a cooking area or connect directly to any appliances.
8. Do not use to exhaust hazardous or explosive materials and vapors.
9. When performing installation, servicing or cleaning this unit, it is recommended to wear safety glasses and gloves.
10. Due to the weight of the unit, two installers are recommended to perform installation.
11. When applicable local regulation comprise more restrictive installation and/or certification requirements, the aforementioned requirements prevail on those of this document and the installer agrees to conform to these at his own expenses.

CAUTION

1. To avoid premature clogged filters, turn OFF the unit during construction or renovation.
2. Please read specification label on product for further information and requirements.
3. Be sure to duct air outside – Do not intake/exhaust air into spaces within walls or ceiling or into attics, crawl spaces, or garage.
4. Intended for residential installation only in accordance with the requirements of NFPA 90B (for a unit installed in U.S.A.) or Part 9 of the National Building Code of Canada (for a unit installed in Canada).
5. Do not run any air ducts directly above or closer than 2 ft (0.61 m) to any furnace or its supply plenum, boiler, or other heat producing appliance. If a duct has to be connected to the furnace return plenum, it must be connected not closer than 9' 10" (3 m) from this plenum connection to the furnace.
6. The ductwork is intended to be installed in compliance with all local and national codes that are applicable.
7. When leaving the house for a long period of time (more than two weeks), a responsible person should regularly check if the unit operates adequately.
8. If the ductwork passes through an unconditioned space (e.g.: attic), the unit must operate continuously except when performing maintenance and/or repair. Also, the ambient temperature of the house should never drop below 18°C (65°F).

TABLE OF CONTENTS

1. TECHNICAL DATA	4-5
1.1 AIR DISTRIBUTION (NORMAL OPERATION)	4
1.2 AIR DISTRIBUTION (DEFROST MODE)	4
1.3 DEFROST CYCLES TABLES.....	4
1.4 DIMENSIONS.....	5
1.4.1 HRV CONSTRUCTO 1.5ES, HRV CONSTRUCTO 2.0ES, HRV SOLO 1.5ES AND HRV SOLO 2.0ES	5
1.4.2 ERV CONSTRUCTO 2.0ES	5
1.5 SPECIFICATIONS	5
2. TYPICAL INSTALLATIONS	6
2.1 FULLY DUCTED SYSTEM	6
2.2 EXHAUST DUCTED SYSTEM (SOURCE POINT VENTILATION)	6
2.3 SIMPLIFIED (VOLUME VENTILATION)	6
3. INSTALLATION	7-13
3.1 INSPECT THE CONTENT OF THE BOX	7
3.2 LOCATING AND MOUNTING THE UNIT	7
3.3 PLANNING OF THE DUCTWORK	7
3.4 CALCULATING THE DUCT SIZE.....	8
3.4.1 EXAMPLE OF CALCULATION	8
3.4.2 EXAMPLE OF A DESIGN FOR A FULLY DUCTED SYSTEM	8
3.5 INSTALLING THE DUCTWORK AND THE REGISTERS	9-10
3.5.1 FULLY DUCTED SYSTEM	9
3.5.2 EXHAUST DUCTED SYSTEM	9
3.5.3 SIMPLIFIED INSTALLATION	10
3.6 CONNECTING THE DUCTS TO THE UNIT	11
3.7 INSTALLING THE EXTERIOR HOODS	12
3.8 CONNECTING THE DRAIN	12-13
3.8.1 HRV UNITS	12
3.8.2 ERV UNIT	13
4. CONTROLS	13-15
4.1 INTEGRATED CONTROL	13
4.1.1 BOOT SEQUENCE	13
4.1.2 SETTING EXTENDED DEFROST	13
4.2 ELECTRICAL CONNECTION TO OPTIONAL WALL CONTROLS	14-15
4.2.1 ELECTRICAL CONNECTION TO ALTITUDE MAIN WALL CONTROL	14
4.2.2 ELECTRICAL CONNECTION TO DECO-TOUCH MAIN WALL CONTROL.....	14
4.2.3 ELECTRICAL CONNECTION TO LITE-TOUCH CONSTRUCTO OR SIMPLE-TOUCH CONSTRUCTO MAIN WALL CONTROL.....	15
4.2.4 ELECTRICAL CONNECTION TO CONSTRUCTO MAIN WALL CONTROL	15
4.2.5 ELECTRICAL CONNECTION TO OPTIONAL AUXILIARY WALL CONTROLS	15
5. ELECTRIC CONNECTION TO THE FURNACE	15
6. WIRING DIAGRAM.....	16
7. BALANCING THE UNIT	17
7.1 WHAT YOU NEED TO BALANCE THE UNIT	17
7.2 PRELIMINARY STAGES TO BALANCE THE UNIT	17
7.3 BALANCING PROCEDURE	17
8. SERVICE PARTS	18
9. TROUBLESHOOTING	19-20

1. TECHNICAL DATA

1.1 AIR DISTRIBUTION (NORMAL OPERATION)

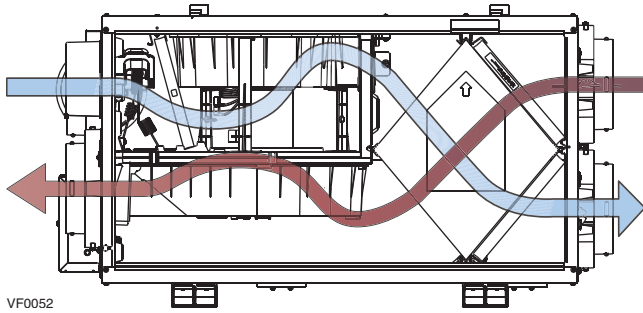

1.2 AIR DISTRIBUTION (DEFROST MODE)

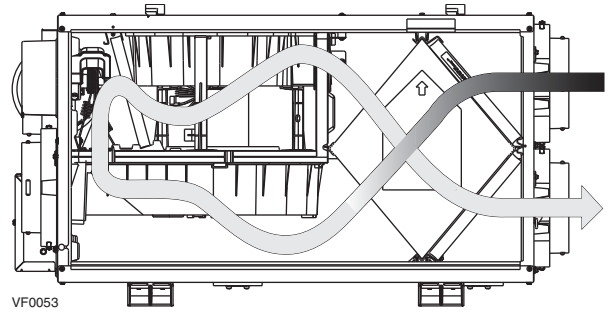

1.3 DEFROST CYCLES TABLES

HRV CONSTRUCTO 1.5ES AND SOLO 1.5ES UNITS

OUTSIDE TEMPERATURE		DEFROST CYCLES (MINUTES)		EXTENDED DEFROST CYCLES	
CELCIUS (°C)	FAHRENHEIT (°F)	DEFROSTING	OPERATION TIME BETWEEN EACH DEFROST CYCLES	DEFROSTING	OPERATION TIME BETWEEN EACH DEFROST CYCLES
-5	23	7	50	10	30
-15	5	7	25	10	20
-27	-17	10	20	10	15

ERV CONSTRUCTO 2.0 ES UNIT

OUTSIDE TEMPERATURE		DEFROST CYCLES (MINUTES)		EXTENDED DEFROST CYCLES	
CELCIUS (°C)	FAHRENHEIT (°F)	DEFROSTING	OPERATION TIME BETWEEN EACH DEFROST CYCLES	DEFROSTING	OPERATION TIME BETWEEN EACH DEFROST CYCLES
-5	23	10	60	10	30
-15	5	10	30	10	20
-27	-17	10	20	10	15

HRV CONSTRUCTO 2.0ES AND SOLO 2.0ES UNITS

OUTSIDE TEMPERATURE		DEFROST CYCLES (MINUTES)		EXTENDED DEFROST CYCLES	
CELCIUS (°C)	FAHRENHEIT (°F)	DEFROSTING	OPERATION TIME BETWEEN EACH DEFROST CYCLES	DEFROSTING	OPERATION TIME BETWEEN EACH DEFROST CYCLES
-5	23	6	50	10	30
-15	5	6	25	10	20
-27	-17	10	20	10	15

NOTE: The Constructo and Solo Performance Charts are listed on the specification sheets of these units. Visit our website at www.venmar.ca to access those documents.

1. TECHNICAL DATA (CONT'D)

1.4 DIMENSIONS

1.4.1 HRV CONSTRUCTO 1.5ES, HRV CONSTRUCTO 2.0ES, HRV SOLO 1.5ES AND HRV SOLO 2.0ES

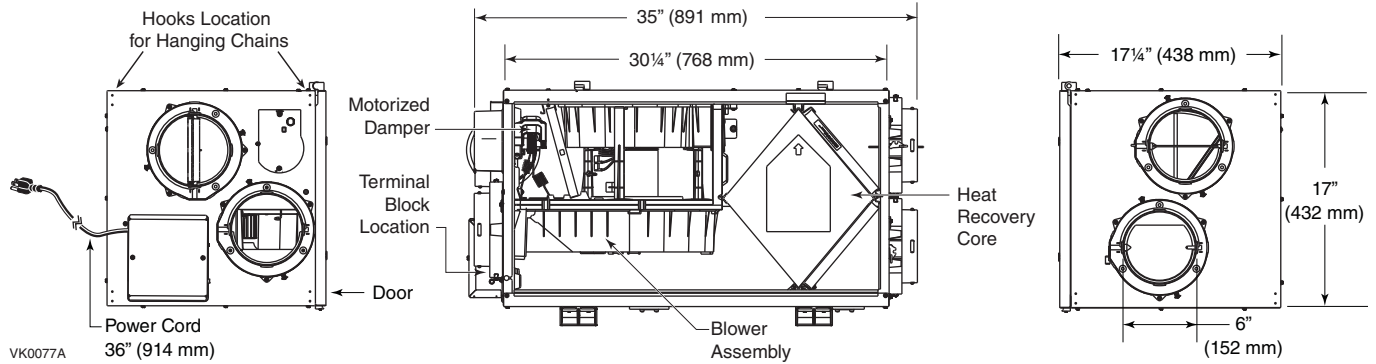

1.4.2 ERV CONSTRUCTO 2.0ES

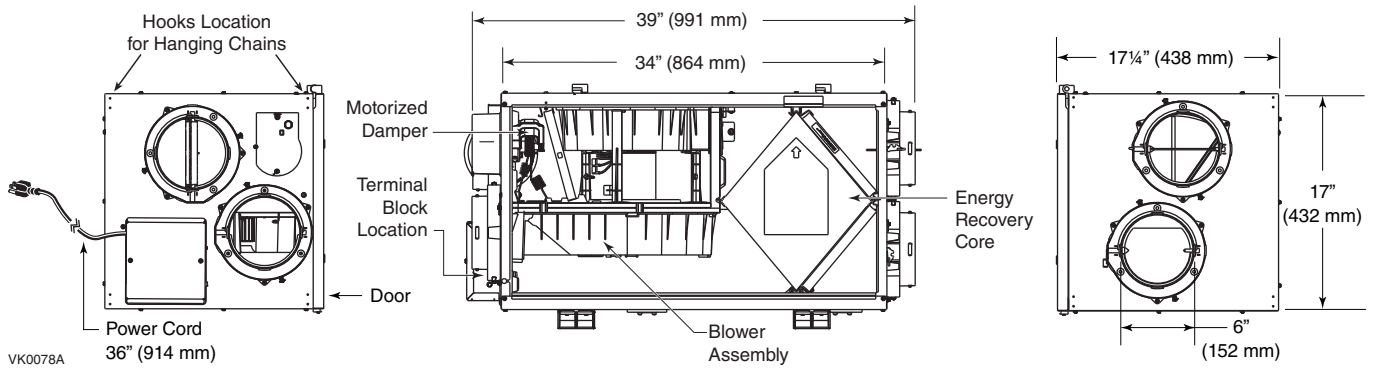

1.5 SPECIFICATIONS

MODEL	HRV CONSTRUCTO 1.5ES	HRV CONSTRUCTO 2.0ES	ERV CONSTRUCTO 2.0ES	HRV SOLO 1.5ES	HRV SOLO 2.0ES
WEIGHT	65 LB. (29.5 kg)	65 LB. (29.5 kg)	76 LB. (34.5 kg)	65 LB. (29.5 kg)	65 LB. (29.5 kg)
PORT DIAMETER	6" (152 MM)	6" (152 MM)	6" (152 MM)	6" (152 MM)	6" (152 MM)
DRAIN DIAMETER	1/2" (12 MM)	1/2" (12 MM)	1/2" (12 MM)	1/2" (12 MM)	1/2" (12 MM)
INSTALLATION	CHAINS AND SPRINGS (PROVIDED WITH THE UNIT)				
MOTOR SPEED	HIGH AND LOW SPEED FACTORY SET (OPTIONAL INCREASED LOW SPEED)				
ELECTRICAL SUPPLY	120 V, 60 Hz	120 V, 60 Hz	120 V, 60 Hz	120 V, 60 Hz	120 V, 60 Hz
POWER CONSUMPTION	160 WATTS	195 WATTS	200 WATTS	160 WATTS	195 WATTS

2. TYPICAL INSTALLATIONS

NOTE: Installation may vary according to the model number and the position; normal or reverse (Solo units only) in which the unit is installed.

There are three common installation methods.

2.1 FULLY DUCTED SYSTEM

(Primarily for homes with radiant hot water or electric baseboard heating. See illustration at right.)

Moist, stale air is exhausted from the high humidity areas in the home, such as bathrooms, kitchen and laundry room.

Fresh air is supplied to bedrooms and principal living areas.

If required, bathroom fans and a range hood may be used to better exhaust stale air.

Homes with more than one level require at least one exhaust register at the highest level.

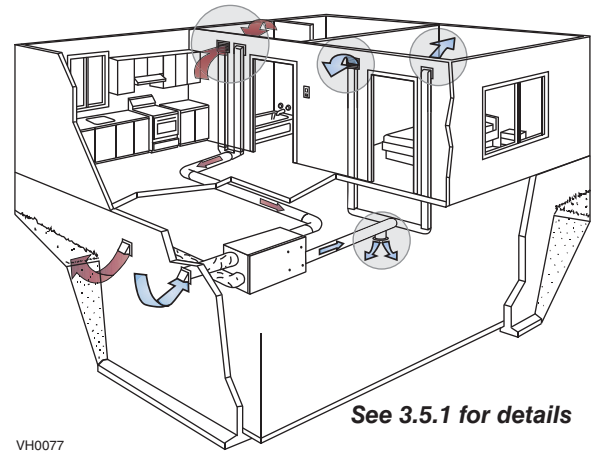

2.2 EXHAUST DUCTED SYSTEM (SOURCE POINT VENTILATION)

(For homes with forced air heating. See illustration at right.)

Moist, stale air is exhausted from the high humidity areas in the home, such as bathrooms, kitchen and laundry room. Fresh air is supplied to the cold air return or the supply duct of the furnace. If required, bathroom fans and a range hood may be used to better exhaust stale air.

Homes with more than one level require at least one exhaust register at the highest level.

NOTE: For this type of installation, it is not essential that the furnace blower runs when the unit is in operation, but we recommend it.

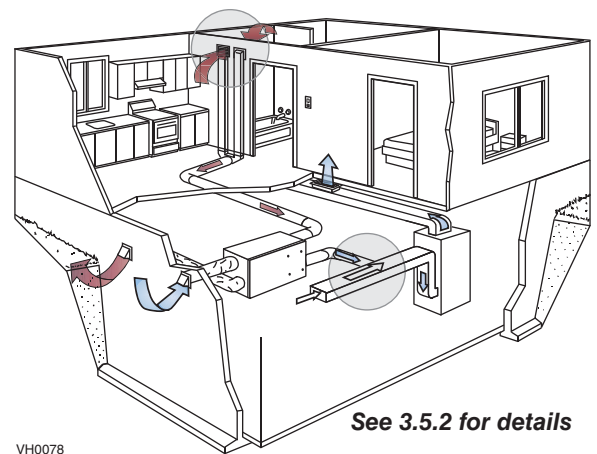

2.3 SIMPLIFIED (VOLUME VENTILATION)

(For homes with forced air heating. See illustration at right.)

Fresh air and exhaust air flow through the furnace ducts, which simplifies the installation.

The use of bathroom fans and a range hood is suggested to exhaust stale air.

NOTE: For this type of installation, the **furnace blower must be running** when the unit is in operation.

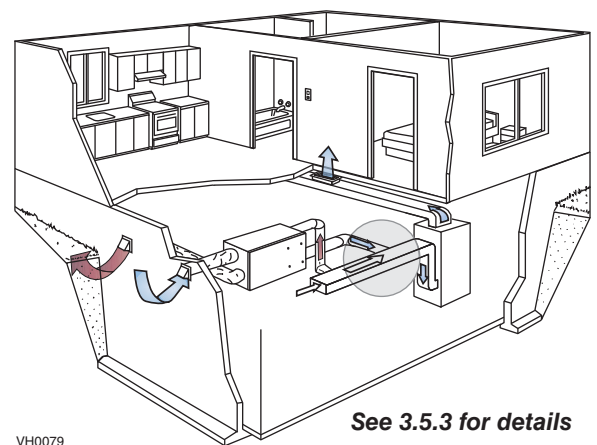

3. INSTALLATION

⚠ WARNING

When applicable local regulation comprises more restrictive installation and/or certification requirements, the aforementioned requirements prevail on those of this document and the installer agrees to conform to these at his own expenses.

⚠ WARNING

When performing installation, servicing or cleaning the unit, it is recommended to wear safety glasses and gloves.

3.1 INSPECT THE CONTENT OF THE BOX

- Inspect the exterior of the unit for shipping damage. Ensure that there is no damage to the door, door latches, door hinges, dampers, duct collars, cabinet, etc.
- Inspect the interior of the unit for damage. Ensure that the fan motor assembly, recovery module, insulation, dampers, condensation tray are all intact.
- If the unit was damaged during shipping, contact your local distributor. (Claim must be made within 24 hours after delivery.)

NOTE: Prior to install the unit, remove its shipping bracket by unscrewing its wing nut and loosening its both retaining screws.

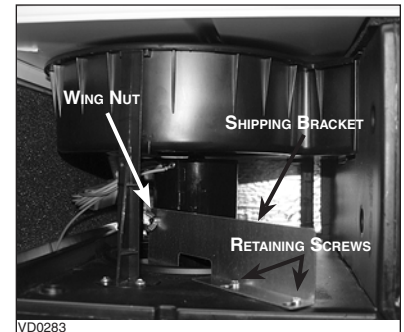

3.2 LOCATING AND MOUNTING THE UNIT

NOTE: Please note that Solo units can be installed in either the normal or reverse (upside down) position.

CAUTION

For Solo units only, when installed in reverse position (upside down) in a cold region where outside temperature could drop below -20°C (-4°F) for more than 5 days in a row, the unit must always be set in extended defrost. See Section 4.1.2 Setting Extended Defrost.

Choose an **appropriate location** for the unit:

- Within an area of the house where the **ambient temperature is kept between 10°C (50°F) and 40°C (104°F)**
- Away from living areas (dining room, living room, bedroom), if possible
- So as to provide easy access to the interior cabinet for every three months and annual maintenance, and to the control panel on the side of the unit;
- Close to an exterior wall, so as to limit the length of the insulated flexible duct to and from the unit
- Close to a drain. If no drain is close by, use a pail to collect run-off
- Away from hot chimneys, electrical panel and other fire hazards
- Allow for a power source (standard outlet)

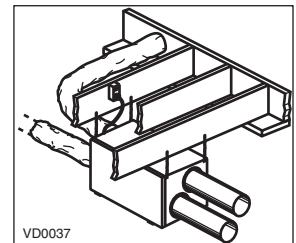

Hang the unit with the 4 chains and springs provided (see illustrations at right).

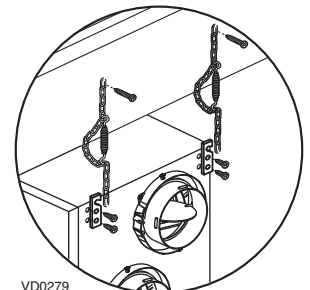

3.3 PLANNING OF THE DUCTWORK

- Follow the instructions in Section 3.4 (next page) to determine the appropriate duct diameters for your system.
- Keep it simple. Plan for a minimum number of bends and joints. Keep the length of insulated duct to a minimum.
- Do not use wall cavities as ducts. Do not use branch lines smaller than $4'' \text{ } \varnothing$ ($102 \text{ mm } \varnothing$).
- Do not ventilate crawl spaces or cold rooms. Do not attempt to recover the exhaust air from a dryer or a range hood. This would cause clogging of the recovery module. Use sheet metal for the kitchen exhaust duct.
- Be sure to plan for at least one exhaust register on the highest lived-in level of the house if it has 2 floors or more.

3. INSTALLATION (CONT'D)

3.4 CALCULATING THE DUCT SIZE

Use the table below to ensure that the ducts you intend to install will be carrying air flows at or under the recommended values. Avoid installing ducts that will have to carry air flows near the maximum values and never install a duct if its air flow exceeds the maximum value.

DUCT DIAMETER	RECOMMENDED AIR FLOW			MAXIMUM AIR FLOW		
	CFM	L/S	M ³ /H	CFM	L/S	M ³ /H
4" (102 MM)	40 CFM	19 L/s	68 M ³ /H	60 CFM	28 L/s	102 M ³ /H
5" (127 MM)	75 CFM	35 L/s	127 M ³ /H	110 CFM	52 L/s	187 M ³ /H
6" (152 MM)	120 CFM	57 L/s	204 M ³ /H	180 CFM	85 L/s	306 M ³ /H
7" (178 MM)	185 CFM	87 L/s	314 M ³ /H	270 CFM	127 L/s	459 M ³ /H
8" (203 MM)	260 CFM	123 L/s	442 M ³ /H	380 CFM	179 L/s	645 M ³ /H

NOTE: Examples 3.4.1 and 3.4.2 use imperial measures. The same calculation applies to metric measures.

3.4.1 EXAMPLE OF CALCULATION

PROBLEM: My installation requires two exhaust registers (one for the kitchen, one for the bathroom). I will connect these registers to a main duct which will connect to the unit (high speed performance value of 140 cfm). What size of duct should I use for the main exhaust duct and for the two end branches leading to the registers? (See illustration at right.)

SOLUTION: Simplified method. (For a more detailed method of calculating duct size refer to the ASHRAE or HRAI HANDBOOK).

Main duct: Table above indicates a 6" Ø duct: Recommended air flow: 120 cfm; maximum air flow: 180 cfm. The high speed air flow of 140 cfm is close enough to the recommended value (120) and far enough away from the maximum value (180). Therefore a 6" Ø duct or larger is an appropriate choice for the main exhaust duct.

End branches: Each end branch will have to transport an air flow of 70 cfm (140 divided by 2). Table above indicates a 5" Ø duct: Recommended air flow: 75 cfm; maximum air flow: 110 cfm. The high speed air flow of 70 cfm is close enough to the recommended value (75) and far enough away from the maximum value (110). Therefore a 5" Ø duct or larger is an appropriate choice for the 2 end branches.

NOTE: A 4" Ø duct would have been too small because the maximum acceptable value for a 4" Ø duct is 60 cfm.

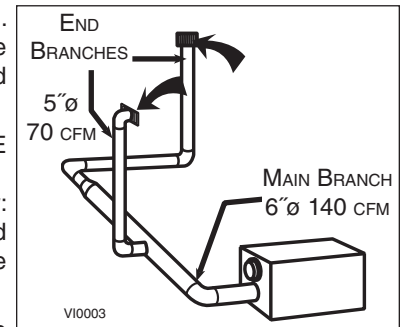

3.4.2 EXAMPLE OF A DESIGN FOR A FULLY DICTED SYSTEM FOR A UNIT HAVING A HIGH SPEED PERFORMANCE OF 222 CFM

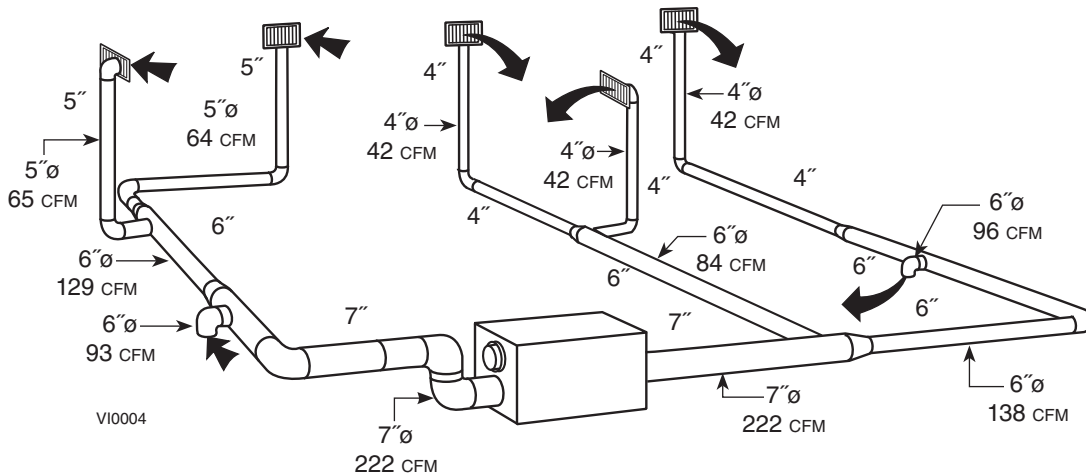

3. INSTALLATION (CONT'D)

3.5 INSTALLING THE DUCTWORK AND THE REGISTERS

⚠ WARNING

Never install a stale air exhaust register in a room where there is a combustion device, such as a gas furnace, a gas water heater or a fireplace.

CAUTION

The ductwork is intended to be installed in compliance with all local and national codes that are applicable.

3.5.1 FULLY DUCTED SYSTEM (AS ILLUSTRATED IN SECTION 2.1)

STALE AIR EXHAUST DUCTWORK:

- Install registers in areas where contaminants are produced: Kitchen, bathrooms, laundry room, etc.
- Install registers 6 to 12 inches (152 to 305 mm) from the ceiling on an interior wall OR install them in the ceiling.
- Install the kitchen register at least 4 feet (1.2 m) from the range.
- If possible, measure the velocity of the air flowing through the registers. If the velocity is higher than 400 ft/min. (122 m/min), then the register type is too small. Replace with a larger one.

FRESH AIR DISTRIBUTION DUCTWORK:

- Install registers in bedrooms, dining room, living room and basement.
- Install registers either in the ceiling or high on the walls with air flow directed towards the ceiling.
(The cooler air will then cross the upper part of the room, and mix with room air before descending to occupant level.)
- If a register must be floor installed, direct the air flow up the wall.

3.5.2 EXHAUST DUCTED SYSTEM (AS ILLUSTRATED IN SECTION 2.2)

STALE AIR EXHAUST DUCTWORK:

Same as for Fully Ducted System, described on point 3.5.1 above)

FRESH AIR DISTRIBUTION:

⚠ WARNING

When performing duct connection to the furnace, installation must be done in accordance with all applicable codes and standards. Please refer to your local building code.

CAUTION

When performing duct connection to the furnace supply duct, this duct must be sized to support the additional airflow produced by the ERV/HRV. Also, use a metal duct. It is recommended that the ERV/HRV is running when the furnace is in operation in order to prevent backdrafting inside ERV/HRV.

There are two methods for connecting the unit to the furnace:

METHOD 1: SUPPLY SIDE CONNECTION

- Cut an opening into the furnace supply duct at least 18 inches (0.5 m) from the furnace.
- Connect this opening to the fresh air distribution port of the HRV/ERV (use metal duct, see illustration at right).
- Make sure that the HRV/ERV duct forms an elbow inside the furnace ductwork.
- If desired, interlock (synchronize) the furnace blower operation with the HRV/ERV operation. (See Section 5).

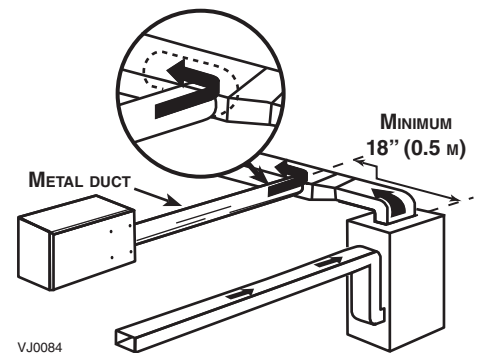

METHOD 2: RETURN SIDE CONNECTION

- Cut an opening into the furnace return duct not less than 10 feet (3.1 m) from the furnace (A+B).
- Connect this opening to the fresh air distribution port of the HRV/ERV (see illustration at right).

NOTE: For Method 2, it is not essential that the furnace blower runs when the unit is in operation, but we recommend it. If desired, synchronize the furnace blower operation with the HRV/ERV operation. (See Section 5).

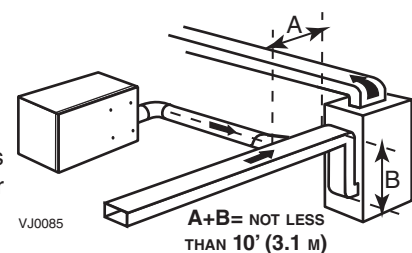

3. INSTALLATION (CONT'D)

3.5 INSTALLING THE DUCTWORK AND THE REGISTERS (CONT'D)

3.5.3 SIMPLIFIED INSTALLATION (AS ILLUSTRATED IN SECTION 2.3)

⚠ WARNING

When performing duct connection to the furnace, installation must be done in accordance with all applicable codes and standards. Please refer to your local building code.

CAUTION

When performing duct connection to the furnace ducts (Method 1), these ducts must be sized to support the additional airflow produced by the ERV/HRV. Also, the supply duct must be a metal duct. It is recommended that the ERV/HRV is running when the furnace is in operation in order to prevent backdrafting inside ERV/HRV.

There are two methods (illustrated below) for connecting the unit to the furnace ducts:

METHOD 1: RETURN-SUPPLY

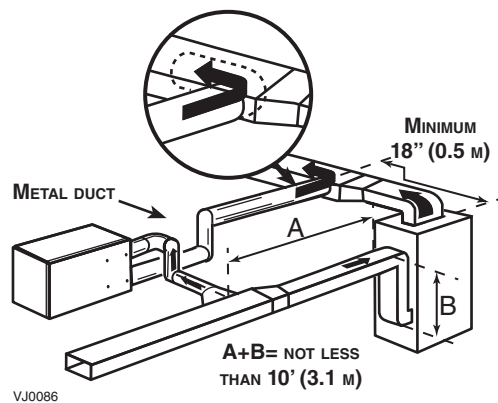

METHOD 2: RETURN-RETURN

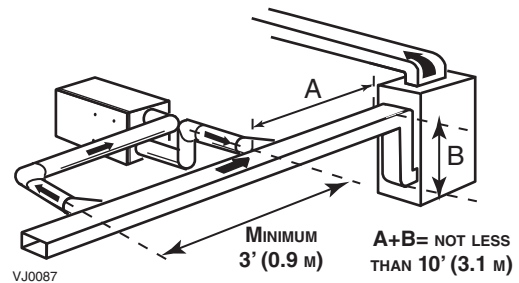

STALE AIR INTAKE:

- Cut an opening into the furnace return duct not less than 10 feet (3.1 m) from the furnace.
- Connect this opening to the stale air intake port of the HRV/ERV (as shown above).

FRESH AIR DISTRIBUTION:

Same instructions as for Method 1 or Method 2, section 3.5.2 in previous page)

CAUTION

If using Method 2, make sure the furnace blower operation is synchronized with the unit operation! See Section 5.

For Method 2 (Return-Return), make sure there is a distance of at least 3 feet (0.9 m) between the 2 connections to the furnace duct.

NOTE: For Method 1, it is not essential to synchronize the furnace blower operation with the HRV/ERV operation, but we recommend it.

3. INSTALLATION (CONT'D)

3.6 CONNECTING THE DUCTS TO THE UNIT

CAUTION

If ducts have to go through an unconditioned space (e.g.: attic), always use insulated ducts.

INSULATED FLEXIBLE DUCTS

Use the following procedure for connecting the insulated flexible duct to the ports on the unit (exhaust to outside and fresh air from outside).

- ① Pull back the insulation to expose the flexible duct and place it **over inner port ring**.
- ② Install good quality **aluminum duct tape** on flexible duct to prevent potential water leakage from duct.
- ③ Attach the flexible duct to the port using tie wrap.
- ④ Pull the insulation over the joint and tuck it **between the inner and outer rings** of the double collar.
- ⑤ Pull down the vapor barrier (shaded part in illustrations below) **over the outer ring** to cover it completely. Fasten in place the vapor barrier using the port strap (included in unit parts bag). To do so, insert one collar pin through vapor barrier and first strap hole, then insert the other collar pin through vapor barrier and center strap hole and close the loop by inserting the first collar pin in the last strap hole.

CAUTION

Make sure the vapor barrier on the insulated ducts does not tear during installation to avoid condensation within the ducts.

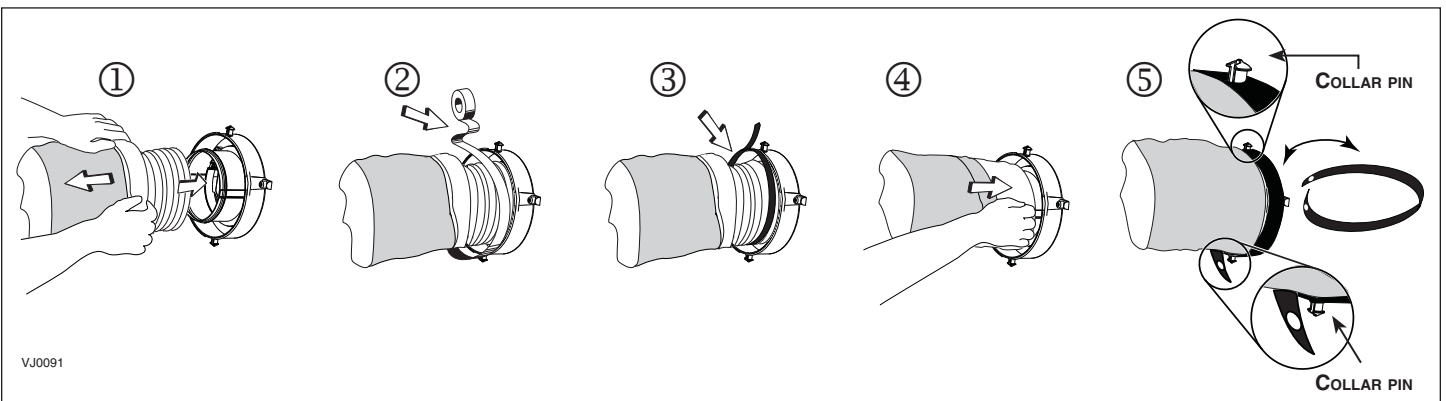

RIGID DUCTS

To prevent potential water leakage from ducts, use good quality aluminum duct tape to connect the rigid ducts to the ports.

CAUTION

Do not use screws to connect rigid ducts to the ports.

Make sure that both balancing dampers are left in a fully open position before connecting the **Fresh air to building port** and **Exhaust air from building port** (as shown in illustration at right).

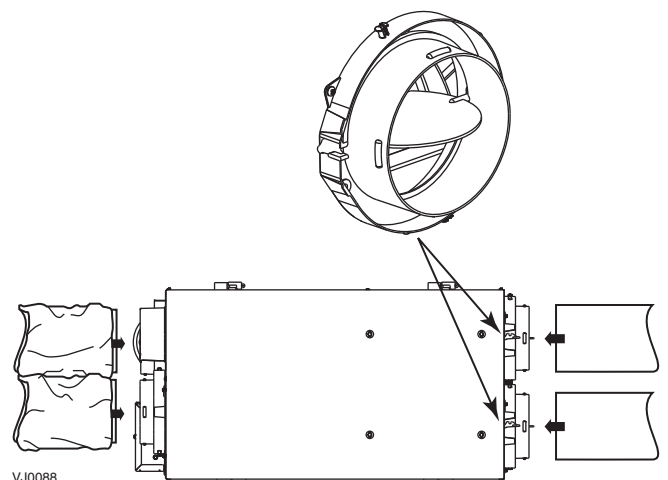

3. INSTALLATION (CONT'D)

3.7 INSTALLING THE EXTERIOR HOODS

Choose an appropriate location for installing the exterior hoods:

- At a minimum distance of 6 feet (1.8 m) between the hoods to avoid cross-contamination
- At a minimum distance of 18 inches (457 mm) from the ground

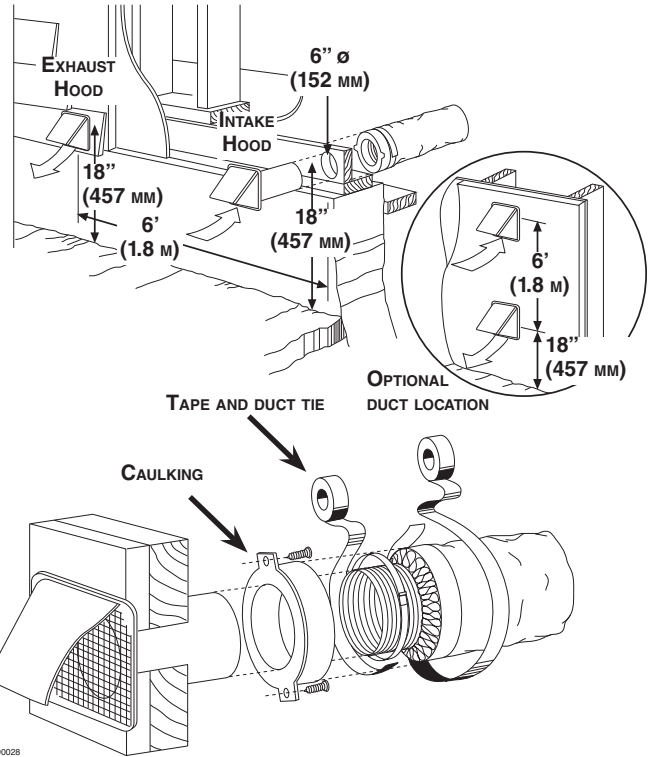

⚠ WARNING

Make sure the intake hood is at least 6 feet (1.8 m) away from any of the following:

- Dryer exhaust, high efficiency furnace vent, central vacuum vent
- Gas meter exhaust, gas barbecue-grill
- Any exhaust from a combustion source
- Garbage bin and any other source of contamination

Refer to illustration at right for connecting the insulated duct to the hoods. An "Anti-Gust Intake Hood" should be installed in regions where a lot of snow is expected to fall.

3.8 CONNECTING THE DRAIN

CAUTION

A drain tubing (included) must be installed for all HRV units. For ERV units, it is not required, however, it is recommended for climates where the outside temperature typically remains below -25°C (-13°F), (over a 24-hour period) for several days in a row, combined with an indoor humidity of 40% or higher.

3.8.1 HRV UNITS

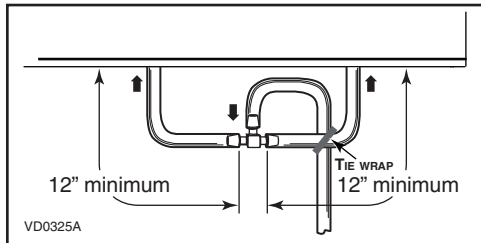

Cut 2 sections of the plastic tube, minimum 12" long, and attach them to each inner drain fitting, located under the unit.

Join both short sections to the "T" junction and main tube as shown, to prevent the unit from drawing unpleasant odors from the drain source.

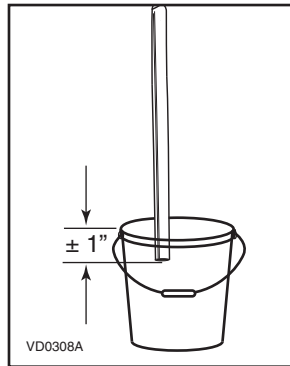

Run the tube to the floor drain or to an alternative drain pipe or pail.

IMPORTANT: If using a pail to collect water, locate the tube end approximately 1" from the top of the pail in order to prevent water from being drawn back up into the unit.

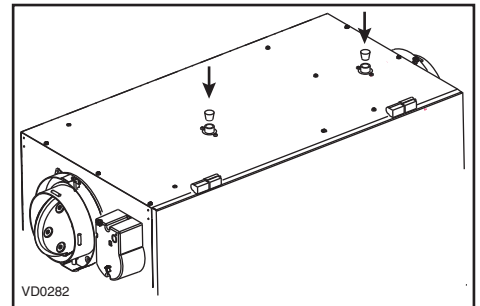

SOLO UNITS ONLY

Insert both drain plugs (included in parts bag) in alternate drain fittings located on top of the unit.

3. INSTALLATION (CONT'D)

3.8 CONNECTING THE DRAIN (CONT'D)

3.8.2 ERV UNIT

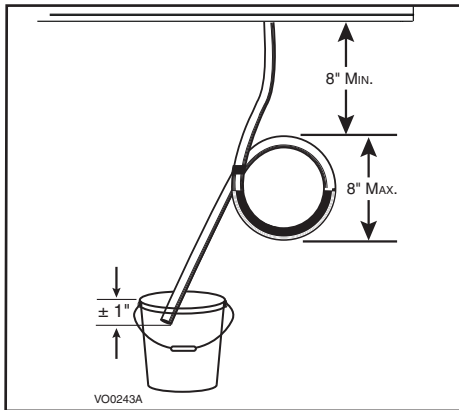

Make a water trap loop in the tube to prevent the unit from drawing unpleasant odors from the drain source. Run the tube to the floor drain or to an alternative drain pipe or pail.

IMPORTANT: If using a pail to collect water, locate the tube end approximately 1" from the top of the pail in order to prevent water from being drawn back up into the unit.

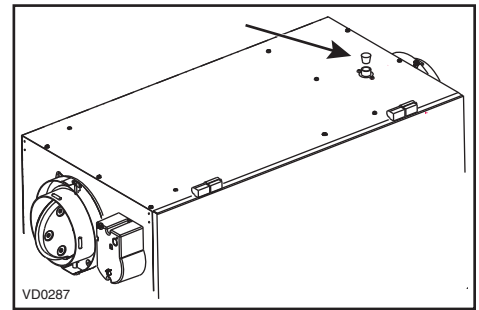

Insert a drain plug (included in parts bag) in alternate drain fitting located on top of the unit.

Furthermore, if the drain will not be used, insert a second drain plug (included in parts bag) in the drain fitting located underneath the unit.

4. CONTROLS

4.1 INTEGRATED CONTROL

All units are equipped with an integrated control, located in front of the electrical compartment. Use the push button (1) to control the unit. The LED (2) will then show on which mode the unit is in.

NOTES: 1. The integrated control **must be turned OFF** to use an optional main control.

2. If an optional auxiliary control is used, if activated, this auxiliary control will override the optional main control.

Refer to table below to see how to operate the unit using its integrated control.

PRESS ON PUSH BUTTON	LED COLOR	RESULTS
ONCE	AMBER	UNIT IS ON LOW SPEED
TWICE	GREEN	UNIT IS ON HIGH SPEED
THREE TIMES	NO LIGHT	UNIT IS OFF

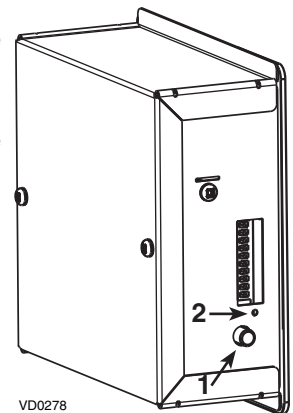

If a problem occurs during the unit operation, its integrated control LED (2) will blink. The color of the blinking light depends on the type of error detected. Refer to Section 9 Troubleshooting on pages 19 and 20 for further details.

4.1.1 BOOT SEQUENCE

The unit boot sequence is similar to a personal computer boot sequence. Each time the unit is plugged after being unplugged, or after a power failure, the unit will perform a 30-second booting sequence before starting to operate. During the booting sequence, the integrated control LED will light GREEN (unit set in normal defrost) or AMBER (unit set in extended defrost) for 5 seconds, and then will shut off for 2 seconds. After that, the LED will light RED for the rest of the booting sequence. During this RED light phase, the unit is checking and resetting the motorized damper position. Once the motorized damper position completely set, the RED light turns off and the booting sequence is done.

NOTE: No command will be taken until the unit is fully booted.

4.1.2 SETTING EXTENDED DEFROST

The unit is factory set to normal defrost. In cold region, it may be necessary to setup extended defrost. During the first 5 seconds of booting sequence, while the integrated control LED is GREEN, press on push button until the LED turns AMBER (about 3 seconds).

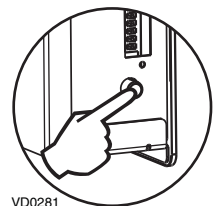

VD0281

CAUTION

For Solo units only, when installed in reverse position (upside down) in a cold region where outside temperature could drop below -20°C (-4°F) for more than 5 days in a row, the unit must always be set in extended defrost.

4. CONTROLS (CONT'D)

4.2 ELECTRICAL CONNECTION TO OPTIONAL WALL CONTROL

For more convenience, this unit can also be controlled using an optional main wall control.

⚠ WARNING

Always disconnect the unit before making any connections. Failure in disconnecting power could result in electrical shock or damage of the wall control or electronic module inside the unit.

CAUTION

Never install more than one optional main wall control per unit. Make sure that the wires do not short-circuit between themselves or by touching any other components on the wall control. Avoid poor wiring connections. To reduce electrical interference (noise) potential, do not run wall control wiring next to control contactors or near light dimming circuits, electrical motors, dwelling/building power or lighting wiring, or power distribution panel.

Use the terminal connector included in the installation kit to perform the electrical connection for main and optional wall controls. Check if all wires are correctly inserted in their corresponding holes in the terminal block. (A wire is correctly inserted when its orange receptacle is lower than another one without wire. On illustration at right, wire **A** is correctly inserted, but not wire **B**.)

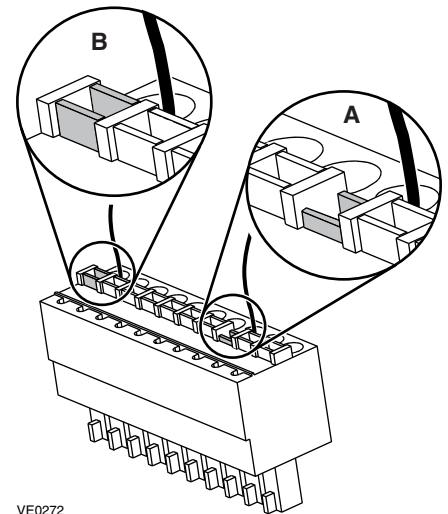

VE0272

Once the wall control(s) connections have been made, insert the terminal connector in the electrical compartment front face.

NOTE: For information about the operation of the wall controls, refer to the user guide.

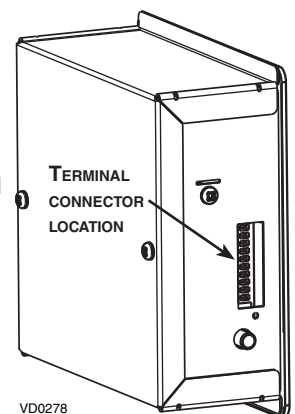

VD0278

4.2.1 ELECTRICAL CONNECTION TO ALTITUDE MAIN WALL CONTROL (EXCLUSIVELY FOR SOLO UNITS)

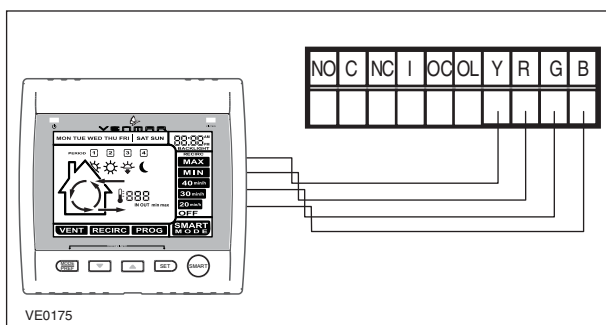

VE0175

4.2.2 ELECTRICAL CONNECTION TO DECO-TOUCH MAIN WALL CONTROL (ALL UNITS)

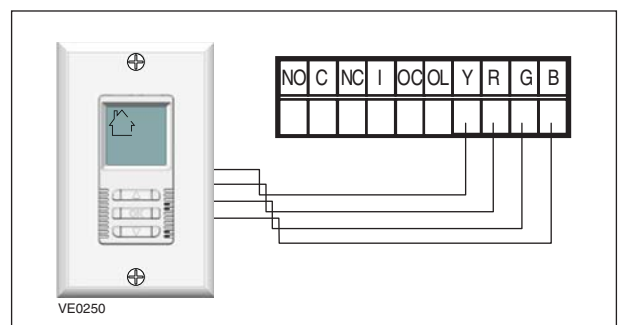

VE0250

4. CONTROLS (CONT'D)

4.2 ELECTRICAL CONNECTION TO OPTIONAL WALL CONTROL (CONT'D)

4.2.3 ELECTRICAL CONNECTION TO LITE-TOUCH CONSTRUCTO (ALL UNITS) OR SIMPLE-TOUCH CONSTRUCTO MAIN WALL CONTROL (EXCLUSIVELY FOR SOLO UNITS)

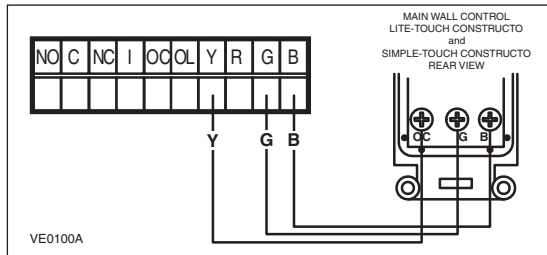

4.2.4 ELECTRICAL CONNECTION TO CONSTRUCTO MAIN WALL CONTROL (ALL UNITS)

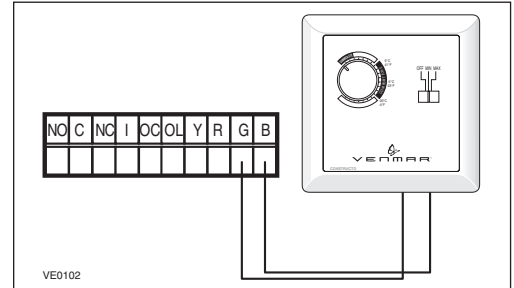

4.2.5 ELECTRICAL CONNECTION TO OPTIONAL AUXILIARY WALL CONTROLS

NOTE: If an optional auxiliary wall control is activated and then, the Dehumidistat is being activated, the operation of this one will override the operation of auxiliary wall control commands.

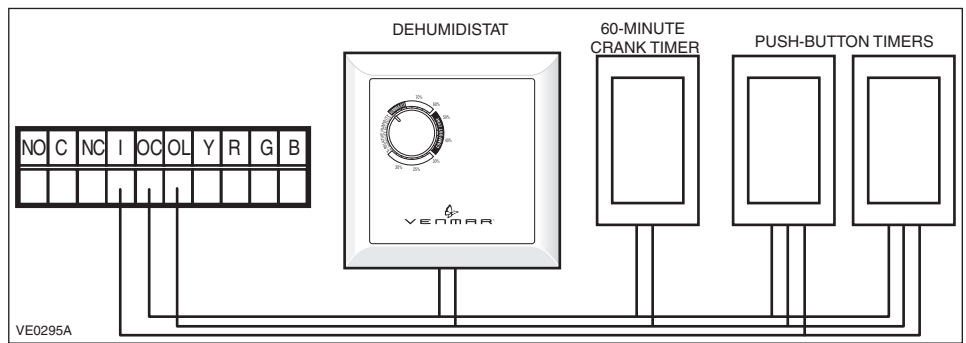

COMPATIBLE OPTIONAL AUXILIARY WALL CONTROLS ACCORDING TO UNIT:

CONSTRUCTO	SOLO
DEHUMIDISTAT	DEHUMIDISTAT
60-MINUTE CRANK TIMER	60-MINUTE CRANK TIMER
20-MINUTE LIGHTED PUSH-BUTTON SWITCH	20/40/60 MINUTE LIGHTED PUSH-BUTTON TIMER

5. ELECTRIC CONNECTION TO THE FURNACE

⚠ WARNING

Never connect a 120-volt AC circuit to the terminals of the furnace interlock (standard wiring). Only use the low voltage class 2 circuit of the furnace blower control.

FOR A FURNACE CONNECTED TO A COOLING SYSTEM:

On some older thermostats, energizing the "R" and "G" terminals at the furnace has the effect of energizing "Y" at the thermostat and thereby turning on the cooling system. If you identify this type of thermostat, you must use the ALTERNATE FURNACE INTERLOCK WIRING.

STANDARD FURNACE INTERLOCK WIRING

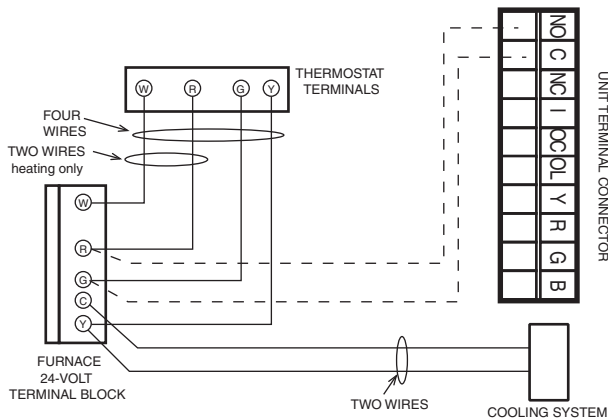

ALTERNATE FURNACE INTERLOCK WIRING

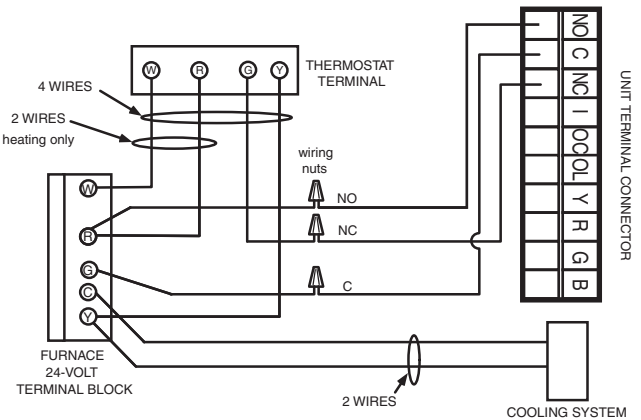

6. WIRING DIAGRAM

⚠ WARNING

- Risk of electric shocks. Before performing any maintenance or servicing, always disconnect the unit from its power source.
- This product is equipped with an overload protection (fuse). A blown fuse indicates an overload or a short-circuit situation. If the fuse blows, unplug the product and check the polarity and voltage output from the outlet. Replace the fuse as per the servicing instructions (refer to wiring diagram for proper fuse rating) and verify the product. If the replaced fuse blows, it may be a short-circuit and the product must be discarded or returned to an authorized service center for examination and/or repair.

LOGIC DIAGRAM

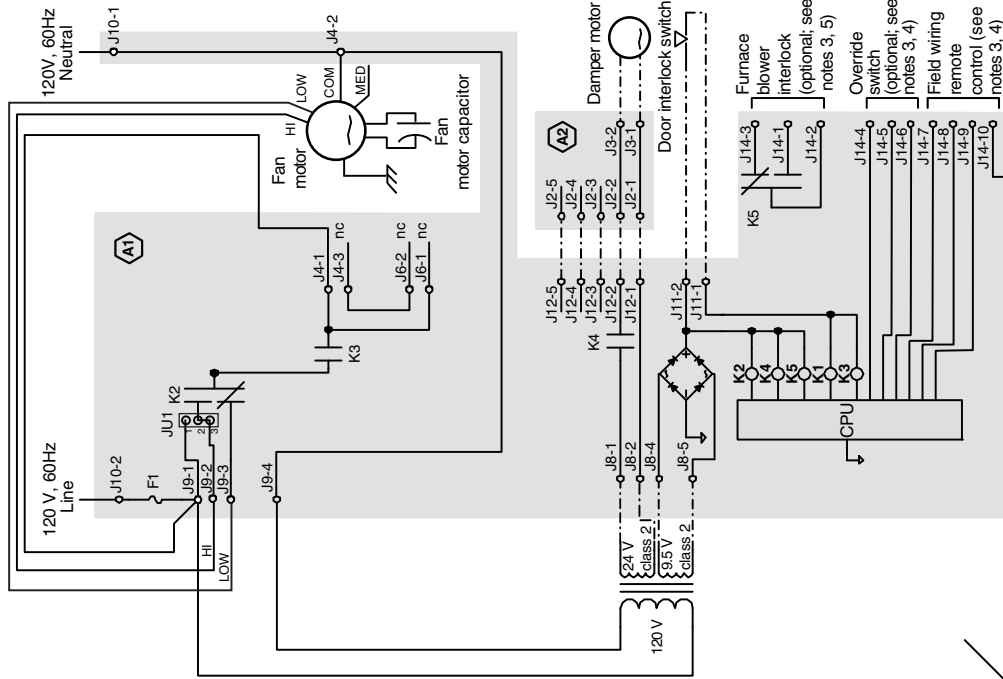

WIRING DIAGRAM

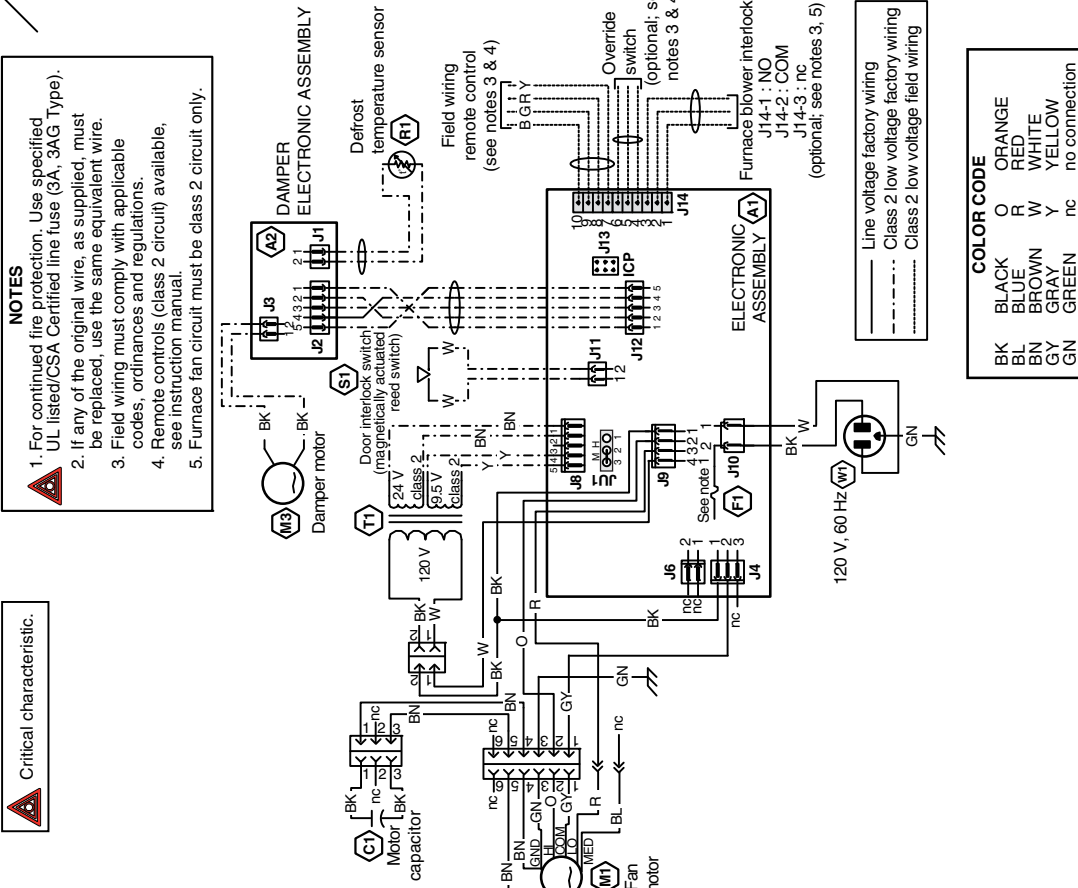

7. BALANCING THE UNIT

7.1 WHAT YOU NEED TO BALANCE THE UNIT

- A magnehelic gauge capable of measuring 0 to 0.5 inch of water (0 to 125 Pa) and 2 plastic tubes.
- The balancing chart of the unit.

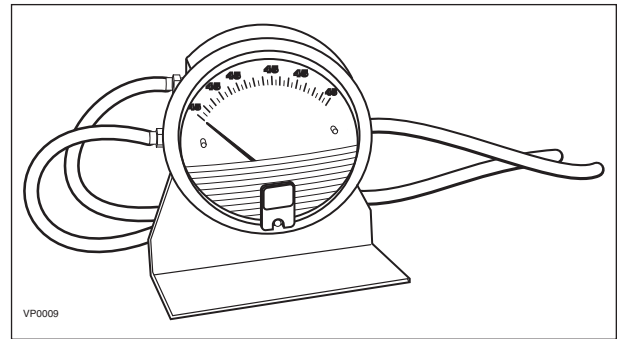

7.2 PRELIMINARY STAGE TO BALANCE THE UNIT

- Seal all the unit ductwork with tape. Close all windows and doors.
- Turn off all exhaust devices such as range hood, dryer and bathroom fans.
- Make sure the integrated balancing dampers are fully open.
- Make sure all filters are clean (if it is not the first time the unit is balanced).

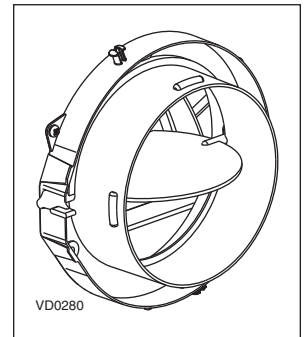

7.3 BALANCING PROCEDURE

1. Set the unit to high speed.

Make sure that the furnace/air handler blower is ON if the installation is in any way connected to the ductwork of the cold air return. If not, leave furnace/air handler blower OFF. If the outside temperature is below 0°C/32°F, make sure the unit is not running in defrost while balancing. (By waiting 10 minutes after plugging the unit in, you are assured that the unit is not in a defrost cycle.)

2. Place the magnehelic gauge on a level surface and adjust it to zero.

3. Connect tubing from gauge to EXHAUST air flow pressure taps (see diagram at right). Be sure to connect the tubes to their appropriate high/low fittings. If the gauge drops below zero, reverse the tubing connections.

NOTE: It is suggested to start with the exhaust air flow reading because the exhaust has typically more restriction than the fresh air, especially in cases of fully ducted installations or source point ventilation.

Place the magnehelic gauge upright and level. Record equivalent AIR FLOW of the reading according to the balancing chart.

4. Move tubing to FRESH air flow pressure taps (see diagram). Adjust the fresh air balancing damper until the FRESH air flow is approximately the same as the EXHAUST air flow. If FRESH air flow is less than EXHAUST air flow, then go back and adjust the exhaust balancing damper to equal the FRESH air flow.

5. Secure both dampers in place with a fastening screw.

6. Write the required air flow information on a label and stick it near the unit for future reference (date, maximum speed air flows, your name, phone number and business address).

7. Install 4 pressure taps plugs (included in parts bag).

NOTES: 1. Use conversion chart provided with the unit to convert magnehelic gauge readings to equivalent cfm values.

2. The unit is considered balanced even if there is a difference of ± 10 cfm (or ± 5 l/s or 17 m³/h) between the two air flows.

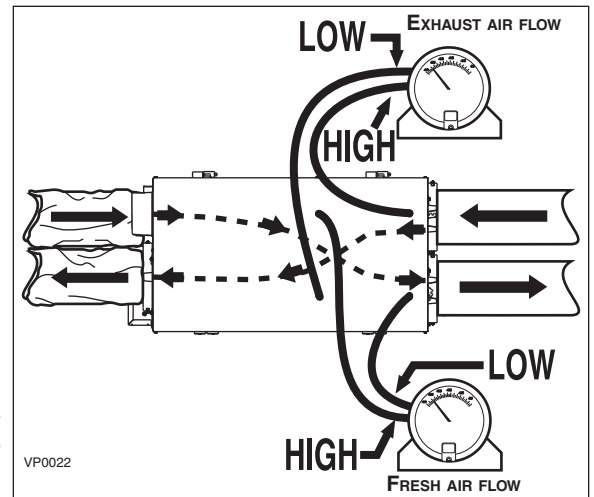

8. SERVICE PARTS

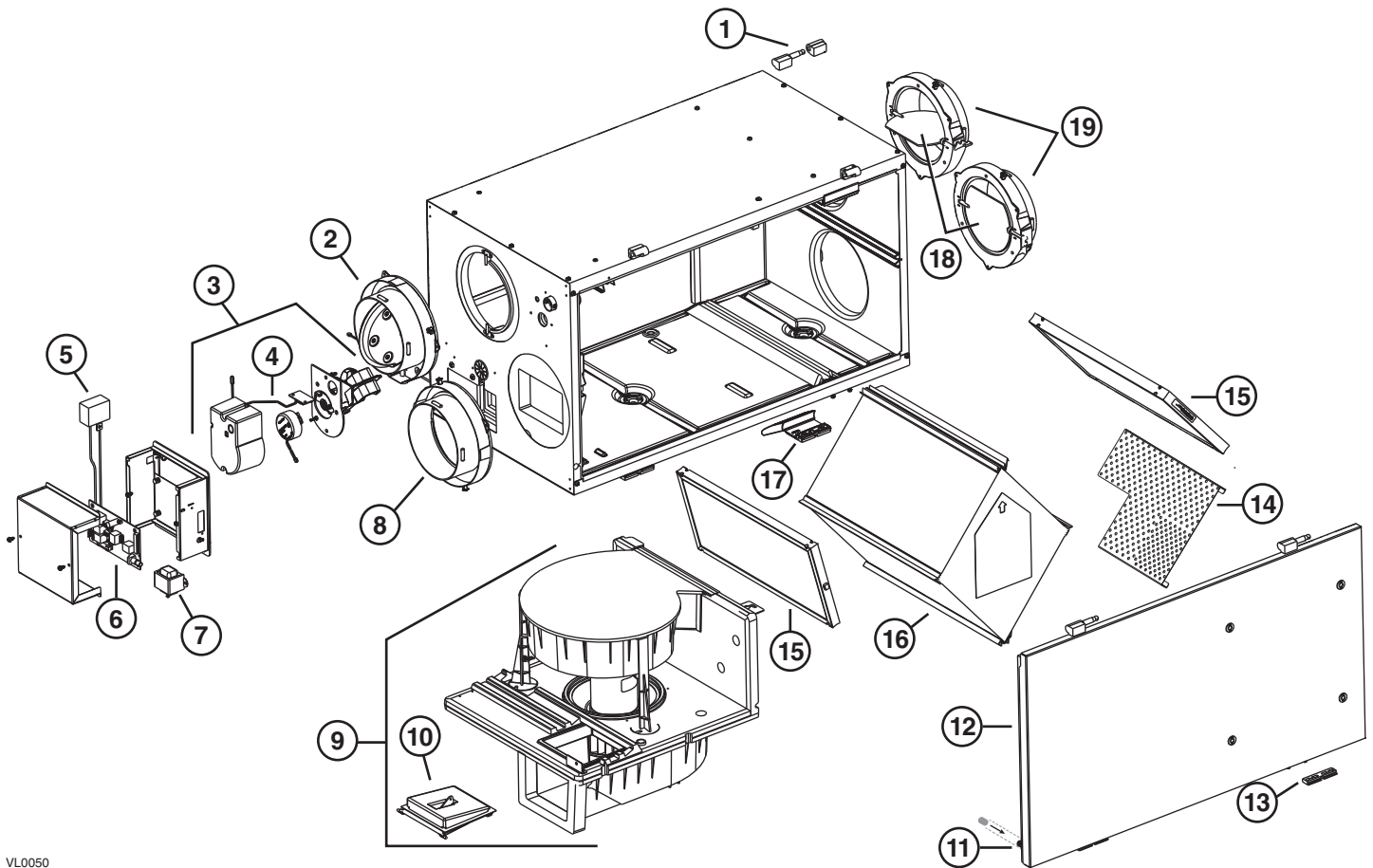

VL0050

ITEM	DESCRIPTION	HRV CONSTRUCTO 1.5ES		HRV CONSTRUCTO 2.0ES	ERV CONSTRUCTO 2.0ES	HRV SOLO 1.5ES		HRV SOLO 2.0ES
		46110	1601702	47110	47115	46720	46725	47720
1	Hinge assembly kit	13036	13036	13036	13036	13036	13036	13036
2	Damper supply port assembly	17245	17245	17245	17245	17245	17245	17245
3	Damper system actuator (including no. 4)	17235	17235	17235	17235	17235	17235	17235
4	Thermistor kit	17242	17242	17242	17242	17242	17242	17242
5	Capacitor 7.5 µF	17240	17240	17240	17240	17240	17240	17240
6	Electronic board	60809	60809	60809	60812	60810	60810	60810
7	Transformer	17244	17244	17244	17244	17244	17244	17244
8	Double collar port	60818	60818	60818	60818	60818	60818	60818
9	Blower assembly (including no. 10)	60804	60804	60805	60806	60804	60804	60805
10	Square damper kit	17243	17243	17243	17243	17243	17243	17243
11	Magnet switch	19060	19060	19060	19060	19060	19060	19060
12	Door assembly (including hinges and latches)	60797	60797	60797	60798	60797	60797	60797
13	Door latches (keeper) and screws	00887 (2) 00601 (4)	00887 (2) 00601 (4)	00887 (2) 00601 (4)	00887 (2) 00601 (4)	00887 (2) 00601 (4)	00887 (2) 00601 (4)	00887 (2) 00601 (4)
14	Diffuser	60822	60822	60822	–	60822	60822	60822
15	Filter kit	60800	60800	60800	60799	60800	60800	60800
16	Core	60802	60801	60803	16582	60802	60801	60803
17	Door latches and screws	00886 (2) 00601 (4)	00886 (2) 00601 (4)	00886 (2) 00601 (4)	00886 (2) 00601 (4)	00886 (2) 00601 (4)	00886 (2) 00601 (4)	00886 (2) 00601 (4)
18	Balancing damper	02253	02253	02253	02253	02253	02253	02253
19	Balancing double collar port	02256	02256	02256	02256	02256	02256	02256
*	Terminal connector	16416	16416	16416	16416	16416	16416	16416
*	Hardware kit	20510	20510	20510	20606	20606	20606	20606

* Not shown.

REPLACEMENT PARTS AND REPAIRS

In order to ensure your ventilation unit remains in good working condition, you must use Venmar Ventilation Inc. genuine replacement parts only. The Venmar Ventilation Inc. genuine replacement parts are specially designed for each unit and are manufactured to comply with all the applicable certification standards and maintain a high standard of safety. Any third party replacement part used may cause serious damage and drastically reduce the performance level of your unit, which will result in premature failing. Also, Venmar Ventilation Inc. recommends to contact a certified service depot for all replacement parts and repairs.

9. TROUBLESHOOTING

If the integrated control LED of the unit is flashing, this means the unit sensors detected a problem. See the list below to know where on the unit the problem occurs.

LED flashes GREEN (double blink).

- Thermistor error.

Replace the thermistor kit.



LED flashes AMBER.

- Damper error.

Go to point 10.

⚠ WARNING

A few diagnosis procedures may require the unit to be in operation while proceeding. Open the unit door and bypass its magnetic switch by putting the door white magnet on it. Be careful with moving and/or live parts.

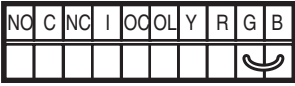
PROBLEMS	POSSIBLE CAUSES	YOU SHOULD TRY THIS
1. The error code E1 is displayed on Altitude or Deco-Touch wall control screen.	<ul style="list-style-type: none"> • The wires may be in reverse position. • The wires may be broken. • The wires may have a bad connection. • The unit is not compatible with Altitude wall control (Constructo). 	<ul style="list-style-type: none"> • Ensure that the color coded wires have been connected to their appropriate places. • Inspect every wire and replace any that are damaged. • Ensure the wires are correctly connected. • Refer to unit spec. sheet for control compatibility.
2. There is no outside temperature displayed on Altitude wall control screen  .	<ul style="list-style-type: none"> • Unit is on error and integrated control LED flashes (GREEN or AMBER). • The unit thermistor is defective (integrated control LED flashes GREEN). 	<p>NOTE: At its very start-up or after a power failure, it takes some minutes before the outside temperature appears on screen. The delay duration depends on which operation mode the wall control is set. The shortest delay is obtained when the wall control is set on MIN or MAX in VENT Mode.</p> <ul style="list-style-type: none"> • Check if unit is operating. • Replace the unit thermistor.
3. Altitude or Deco-Touch wall control screen alternates between normal display and E3 or E4 appears on screen.	<ul style="list-style-type: none"> • The Altitude or Deco-Touch wall control needs to be reset. • The Altitude or Deco-Touch wall control is defective. 	<ul style="list-style-type: none"> • Reset the Altitude or Deco-Touch wall control by pressing simultaneously on both keys for 8 second (as shown at right). Then, unplug the unit for 30 seconds. Plug the unit back. • If the problem is not solved, replace the Altitude or Deco-Touch wall control. 
4. On Altitude wall control, there is an important difference between temperature displayed and real temperature.	<ul style="list-style-type: none"> • Exterior air intake port is blocked. • The unit thermistor is defective (integrated control LED flashes GREEN). • The unit damper has been blocked or broken (integrated control LED flashes AMBER and unit is OFF). • Motor won't turn. 	<ul style="list-style-type: none"> • Clean the exterior air intake port. • Replace the unit thermistor. • Check for the proper operation of the unit damper; replace if necessary. • Confirm that the motor is running, if not refer to point 9.
5. Unit does not work (no LED is lit on the integrated control).	<ul style="list-style-type: none"> • The transformer may be defective. • The circuit board may be defective. • The unit is unplugged. • The unit door is opened. • A fuse is blown. • Wrong control connections. 	<ul style="list-style-type: none"> • Check for 24 VAC on J8-1 and J8-2. • Unplug the unit. Disconnect the main control and the optional(s) control(s) (if need be). Jump G and B terminals. Plug the unit back and wait about 10 seconds. If the motor runs on high speed and the damper opens, the circuit board is not defective. • Plug the unit. • Close unit door. • Inspect fuse on circuit board (refer to wiring diagram F1 on page 16). • Try the integrated control (see Section 4.1 on page 13). 
6. The damper actuator does not work or rotates continuously.	<ul style="list-style-type: none"> • The damper actuator or the integrated damper port mechanism may be defective (integrated control LED flashes AMBER and unit is OFF). • The circuit board or the transformer may be defective.(integrated control LED flashes AMBER and unit is OFF) 	<ul style="list-style-type: none"> • Unplug the unit. Disconnect the main control and the optional controls(s) (if need be). Wait 10 seconds and plug the unit back. Check if the damper opens. If not, use a multimeter and check for 24VAC on J12-1 and J12-2 (in electrical compartment). If there is 24VAC, replace the entire port assembly. NOTE: It is normal to experience a small delay (7-8 seconds) before detecting the 24VAC signal at starting-up. This signal will stay during 17-18 seconds before disappearing. • If there is no 24 VAC, check for 24 VAC between J8-1 and J8-2. If there is 24 VAC replace the circuit board, and if there is no 24 VAC, change the transformer.

9. TROUBLESHOOTING (CONT'D)

PROBLEMS	POSSIBLE CAUSES	YOU SHOULD TRY THIS
7. The wall control does not work OR its indicator flashes.	<ul style="list-style-type: none"> The wires may be in reverse position. The wires may be broken. The wire in the wall OR the wall control may be defective. 	<ul style="list-style-type: none"> Ensure that the color coded wires have been connected to their appropriate places. Inspect every wire and replace any that are damaged. Remove the wall control and test it right beside the unit using another shorter wire. If the wall control works there, change the wire. If it does not, change the wall control.
8. The Dehumidistat does not work OR the push-button timer does not work OR its indicator light does not stay on.	<ul style="list-style-type: none"> The wires may be in reverse position. The Dehumidistat or push button may be defective. 	<ul style="list-style-type: none"> Ensure that the color coded wires have been connected to their appropriate places. Jump the OL and OC terminals. If the unit switches to high speed, remove the Dehumidistat or push button and test it right beside the unit using another shorter wire. If it works here, change the wire. If it doesn't, change the Dehumidistat or the push button.  <p>VE0098</p>
9. The motor does not work.	<ul style="list-style-type: none"> The circuit board may be defective. The motor may be defective. The motor capacitor may be defective. The motor is unplugged from inside the unit. The motor is unplugged from the electronic board (J4). There is a problem with the door magnet switch. JU-1 jumper is missing or in wrong position. 	<ul style="list-style-type: none"> Press on the integrated control push button until the unit turns on low speed (the LED will light AMBER). Using a multimeter, check the voltage on J9-4 and J9-3. Refer to Section 6 Wiring Diagram. The reading must be 120VAC Then set the unit on high speed by pressing on the integrated control push button one more time (the LED will light GREEN). Using a multimeter, check the voltage on J9-4 and J9-2. The reading must be 120VAC Check also between J4-2 and J4-1, the reading must be 120VAC Refer to Section 6 Wiring Diagram. Check if the fuse F1 is intact. If all the readings correspond to the right voltage values, the circuit board is not defective. If one or both readings are different, change the circuit board. Using a multimeter, check for 120VAC for the following speeds: High Speed: between GREY and ORANGE wires; Low/Medium Speed: between GREY and RED/BLUE wires. Refer to Section 6 Wiring Diagram. Unplug the unit. Check for continuity between Pin 5 on the 6-pin connector (brown leads) and Pin 3 of the capacitor connector. Also check for continuity between Pin 4 on the 6-pin connector (brown leads) and Pin 1 of the capacitor connector. Refer to Section 6 Wiring Diagram. Open the door and ensure that the wire going to the motor is connected. Check J4 motor connection on circuit board. Door magnet switch is missing or not in its place (see item no. 11 on page 18). Ensure JU-1 jumper is set on "M" speed (refer to Section 6 Wiring Diagram).
10. The defrost cycle does not work (the fresh air duct is frozen OR the fresh air distributed is very cold).	<ul style="list-style-type: none"> Ice deposits may be hindering the damper operation. The damper rod or the port damper itself may be broken. The damper actuator or circuit board may be defective. 	<ul style="list-style-type: none"> Remove the ice. Inspect these parts and replace if necessary. See point 6.
11. The integrated control push button does not work.	<ul style="list-style-type: none"> The 30-second boot sequence is not completed. The circuit board may be defective. The transformer may be defective. 	<ul style="list-style-type: none"> See Section 4.1.1 Boot Sequence (page 13). Check voltage going to circuit board J8-1 and J8-2. Check for 24 VAC on J8-1 and J8-2.