

INSTALLATION GUIDE

VENMAR AVS

VÄNEE

SIDE PORTS

TOP PORTS

SIDE PORTS

TOP PORTS

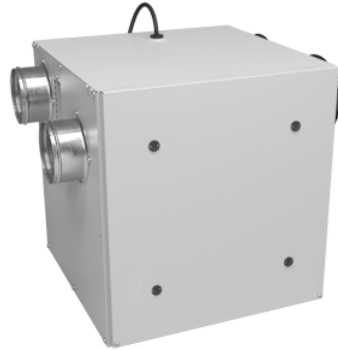
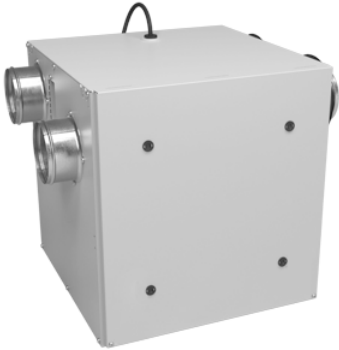

VB0201

VB0200

VB0201

VB0200

K7 ERV Model no. 44163

K7 ERV Model no. 44162

40E Model no. 44263

40E Model no. 44262

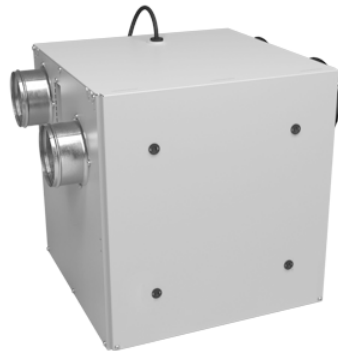
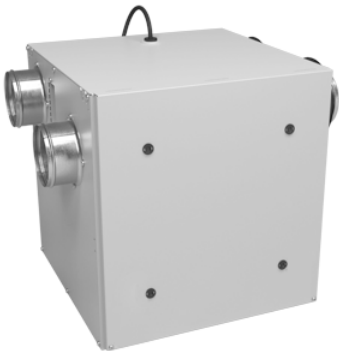

VB0201

VB0200

VB0201

VB0200

K8 HRV* Model no. 44153
K10 HRV* Model no. 44502

K8 HRV* Model no. 44152
K10 HRV* Model no. 44500

40H+* Model no. 44253
50H* Model no. 44602

40H+* Model no. 44252
50H* Model no. 44600



* These products earned the ENERGY STAR® by meeting strict energy efficiency guidelines set by Natural Resources Canada and the US EPA. They meet ENERGY STAR requirements only when used in Canada.

⚠ RESIDENTIAL INDOOR USE ONLY ⚠

READ AND SAVE THESE INSTRUCTIONS



7 72371 13063 0

ABOUT THIS GUIDE

Because of the large amount of models covered in this publication, the illustrations are typical ones. Some details of your unit may be slightly different than the ones shown.

Please take note that this manual uses the following symbols to emphasize particular information:

⚠ WARNING

Identifies an instruction which, if not followed, might cause serious personal injuries including possibility of death.

CAUTION

Identifies an instruction which, if not followed, may severely damage the unit and/or its components.

NOTE: Indicates supplementary information needed to fully complete an instruction.

ABOUT THESE UNITS

LIMITATION

For residential (domestic) installation only. Installation work and electrical wiring must be done by a qualified person(s) in accordance with all applicable codes and standards, including fire-rated construction codes and standards.

⚠ WARNING

TO REDUCE THE RISK OF FIRE, ELECTRIC SHOCK, OR INJURY TO PERSON(S) OBSERVE THE FOLLOWING:

1. Use this unit only in the manner intended by the manufacturer. If you have questions, contact the manufacturer at the address or telephone number listed in the warranty.
2. We recommend that your unit be inspected by a specialized technician once a year.
3. Before servicing or cleaning the unit, disconnect power cord from electrical outlet.
4. This unit is not designed to provide combustion and/or dilution air for fuel-burning appliances.
5. When cutting or drilling into wall or ceiling, do not damage electrical wiring and other hidden utilities.
6. Do not use the units with any solid-state speed control device other than the corresponding ones listed below:

| UNIT | MAIN CONTROL | AUXILIARY CONTROL |
|----------------------------|---|--|
| K7 ERV, K8 HRV AND K10 HRV | ALTITUDE, DECO-TOUCH, LITE-TOUCH CONSTRUCTO, SIMPLE TOUCH CONSTRUCTO OR CONSTRUCTO | 20/40/60-MINUTE PUSH-BUTTON TIMER, 20-MINUTE LIGHTED PUSH BUTTON, 60-MINUTE CRANK TIMER AND DEHUMIDISTAT |
| 40E, 40H+ AND 50H | PLATINUM, DECO-TOUCH, LITE-TOUCH BRONZE, SIMPLE TOUCH BRONZE OR BRONZE | |

7. This unit must be grounded. The power supply cord has a 3-prong grounding plug for your personal safety. It must be plugged into a mating 3-prong grounding receptacle, grounded in accordance with the national electrical code and local codes and ordinances. Do not remove the ground prong. Do not use an extension cord.
8. Do not install in a cooking area or connect directly to any appliances.
9. Do not use to exhaust hazardous or explosive materials and vapors.
10. When performing installation, servicing or cleaning the unit, it is recommended to wear safety glasses and gloves.
11. Due to the weight of the unit, two installers are recommended to perform installation.
12. When applicable local regulations comprise more restrictive installation and/or certification requirements, the aforementioned requirements prevail on those of this document and the installer agrees to conform to these at his own expenses.

CAUTION

1. To avoid premature clogged filters, turn OFF the unit during construction or renovation.
2. Please read specification label on product for further information and requirements.
3. Be sure to duct air outside – Do not intake/exhaust air into spaces within walls or ceiling or into attics, crawl spaces, or garage.
4. Intended for residential installation only in accordance with the requirements of NFPA 90B (for a unit installed in U.S.A.) or Part 9 of the National Building Code of Canada (for a unit installed in Canada).
5. Do not run any air ducts directly above or closer than 2 ft (0.61 m) to any furnace or its supply plenum, boiler, or other heat producing appliance. If a duct has to be connected to the furnace return plenum, it must be connected not closer than 9' 10" (3 m) from this plenum connection to the furnace.
6. The ductwork is intended to be installed in compliance with all applicable codes.
7. When leaving the house for a long period of time (more than two weeks), a responsible person should regularly check if the unit operates adequately.
8. If the ductwork passes through an unconditioned space (e.g.: attic), the unit must operate continuously except when performing maintenance and/or repair. Also, the ambient temperature of the house should never drop below 18°C (65°F).

TABLE OF CONTENTS

| | |
|---|-------|
| 1. TECHNICAL SUPPORT | 3 |
| 2. TECHNICAL DATA | 3-4 |
| 2.1 AIR DISTRIBUTION | 3 |
| 2.2 DEFROST CYCLES | 4 |
| 2.3 TOP PORTS UNITS DIMENSIONS | 4 |
| 2.4 SIDE PORTS UNITS DIMENSIONS | 4 |
| 3. TYPICAL INSTALLATIONS | 5 |
| 3.1 FULLY DUCTED SYSTEM | 5 |
| 3.2 CENTRAL DRAW POINT | 5 |
| 3.3 SIMPLIFIED INSTALLATION | 5 |
| 4. INSTALLATION | 6-11 |
| 4.1 INSPECT THE CONTENT OF THE BOX | 6 |
| 4.2 LOCATING THE UNIT | 6 |
| 4.3 PLANNING OF THE DUCTWORK | 6 |
| 4.4 INSTALLING THE DUCTWORK AND REGISTERS | 6-8 |
| 4.5 CONNECTING THE DUCTS TO THE UNIT | 9 |
| 4.6 INSTALLING TWO EXTERIOR HOODS | 10 |
| 4.7 INSTALLING SINGLE EXTERIOR HOOD USING TANDEM® TRANSITION KIT (OPTIONAL) | 10 |
| 4.8 CONNECTING THE DRAIN | 11 |
| 5. CONTROLS | 11-14 |
| 5.1 UNITS BOOTING SEQUENCE | 11 |
| 5.2 INTEGRATED CONTROL | 11 |
| 5.3 SETTING EXTENDED DEFROST | 12 |
| 5.4 ELECTRICAL CONNECTION TO MAIN CONTROLS | 12-13 |
| 5.5 ELECTRICAL CONNECTION TO OPTIONAL AUXILIARY CONTROLS | 14 |
| 6. ELECTRICAL CONNECTION TO THE FURNACE | 14 |
| 7. WIRING DIAGRAM | 15 |
| 8. BALANCING THE UNIT | 16 |
| 8.1 WHAT YOU NEED TO BALANCE THE UNIT | 16 |
| 8.2 PRELIMINARY STAGES TO BALANCE THE UNIT | 16 |
| 8.3 BALANCING PROCEDURE | 16 |
| 9. SERVICE PARTS | 17-18 |
| 10. TROUBLESHOOTING | 19-20 |

1. TECHNICAL SUPPORT (FOR ASSISTANCE)

FOR ASSISTANCE, CALL ON WEEKDAYS, 8:30 AM TO 5:00 PM (EASTERN STANDARD TIME).

NOTE: THESE PHONE NUMBERS ARE STRICTLY RESERVED FOR INSTALLERS USE ONLY. DO NOT CALL THESE NUMBERS FOR ORDERING PARTS.

FOR VENMAR UNITS: 1-800-649-0372 (TOOL FREE)

FOR VANEE UNITS: 1-888-908-2633 (TOLL FREE)

2. TECHNICAL DATA

2.1 AIR DISTRIBUTION

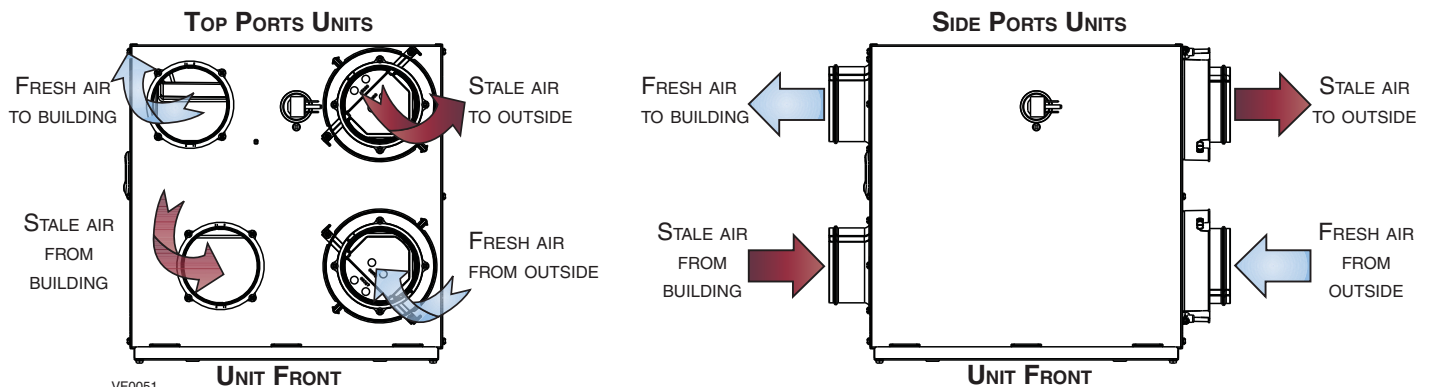

VF0051

2. TECHNICAL DATA (CONT'D)

2.2 DEFROST CYCLES

| K8 HRV, K10 HRV, 40H+ AND 50H UNITS | | | | | |
|-------------------------------------|-----|--------------------------|--------------------------------------|------------------------------------|--------------------------------------|
| OUTSIDE TEMPERATURE | | DEFROST CYCLES (MINUTES) | | EXTENDED DEFROST* CYCLES (MINUTES) | |
| °C | °F | DEFROSTING | OPERATION BETWEEN EACH DEFROST CYCLE | DEFROSTING | OPERATION BETWEEN EACH DEFROST CYCLE |
| -5 | 23 | 5 | 30 | 6 | 20 |
| -15 | 5 | 5 | 20 | 6 | 15 |
| -27 | -17 | 7 | 15 | 7 | 12 |

| K7 ERV AND 40E UNITS | | | | | |
|----------------------|-----|--------------------------|--------------------------------------|------------------------------------|--------------------------------------|
| OUTSIDE TEMPERATURE | | DEFROST CYCLES (MINUTES) | | EXTENDED DEFROST* CYCLES (MINUTES) | |
| °C | °F | DEFROSTING | OPERATION BETWEEN EACH DEFROST CYCLE | DEFROSTING | OPERATION BETWEEN EACH DEFROST CYCLE |
| -5 | 23 | 7 | 22 | 7 | 15 |
| -15 | 5 | 7 | 22 | 7 | 15 |
| -27 | -17 | 7 | 15 | 7 | 12 |

* In a cold region (outside temperature -27°C [-17°F] and lower), it may be necessary to setup EXTENDED DEFROST. See Section 5.3.

2.3 TOP PORTS UNITS DIMENSIONS

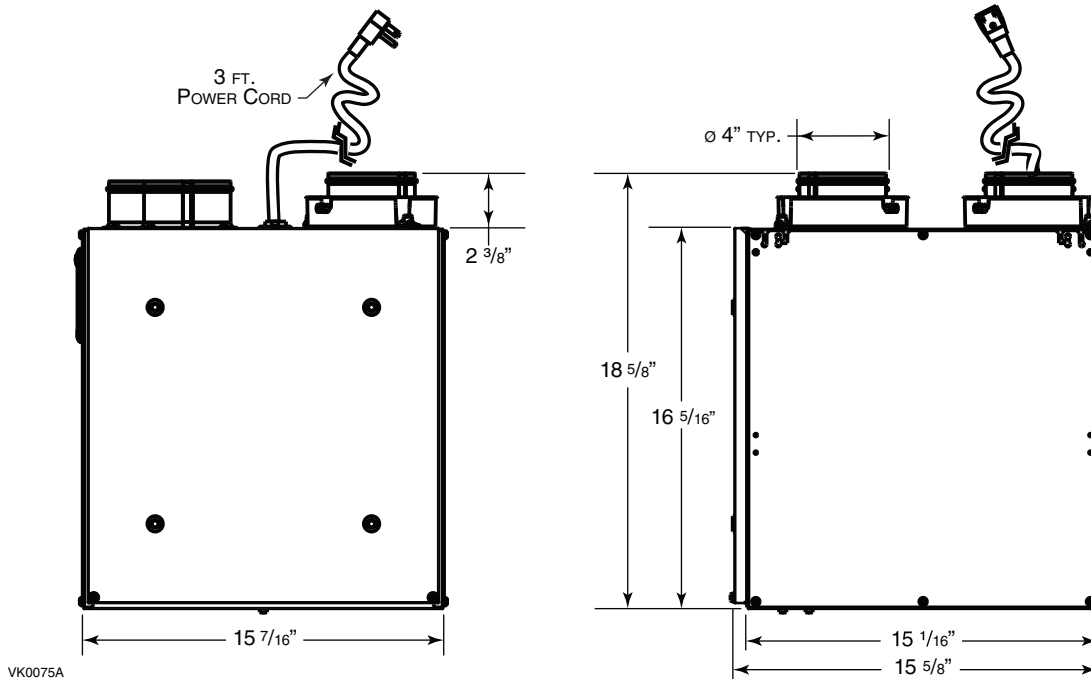

2.4 SIDE PORTS UNITS DIMENSIONS

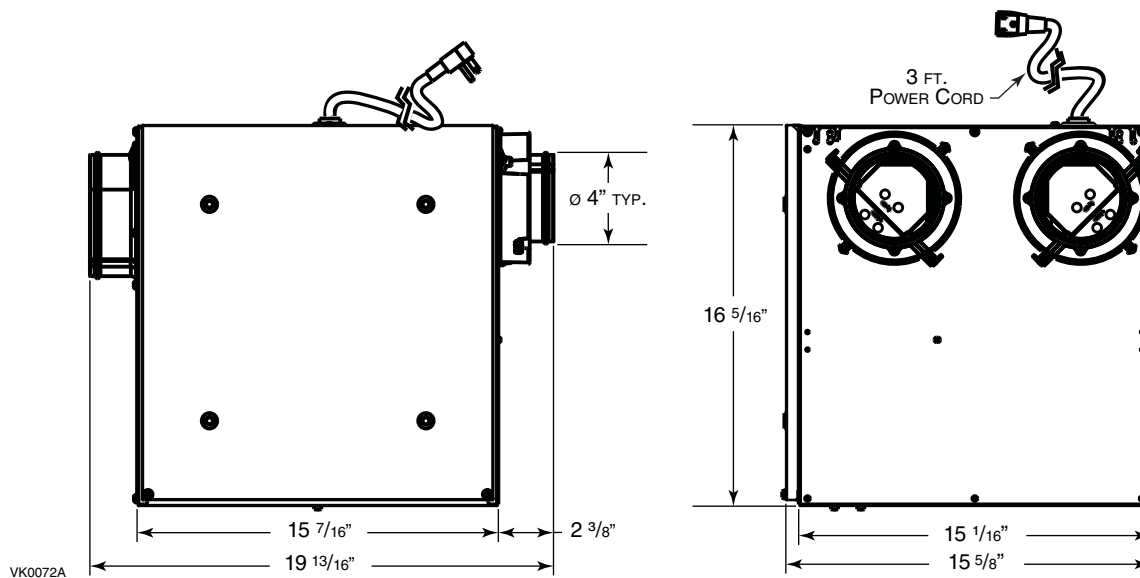

3. TYPICAL INSTALLATIONS

Use the following illustrations as guidelines to help you decide on how the unit will be installed.

All the units should be hung from the joists.

If required, bathroom fans and a range hood may be used to exhaust stale air. Also, for homes with more than one level, we recommend one exhaust register at the highest level.

There are 3 installation methods: Fully ducted, Central Draw Point and Simplified Installation.

NOTE: An electrical outlet has to be available within 3 feet of the unit.

3.1 FULLY DUCTED SYSTEM (PRIMARYLY FOR HOMES WITH RADIANT HOT WATER OR ELECTRIC BASEBOARD HEATING)

Stale air coming from the registers located at the highest level of the house is exhausted to the outside. Fresh air from outside is filtered and supplied by the register located in the lowest liveable level.

Homes with more than one level require at least one exhaust register at the highest level.

See figure at right.

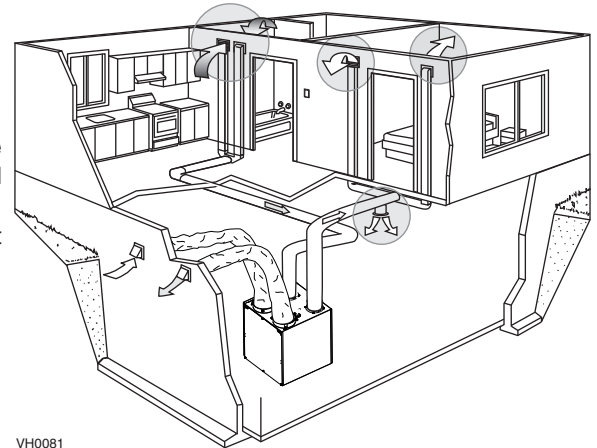

3.2 CENTRAL DRAW POINT (CONNECTION TO A FORCED AIR SYSTEM)

Stale air coming from the registers located at the highest level of the house is exhausted to the outside. Fresh air from outside is filtered and supplied to the return (plenum) or the supply duct of the forced air unit. See figure at right.

For this type of installation, it is not essential that the forced air system blower runs when the unit is in operation, but we recommend it.

NOTE: Home with multiple forced air systems should have one unit on each system.

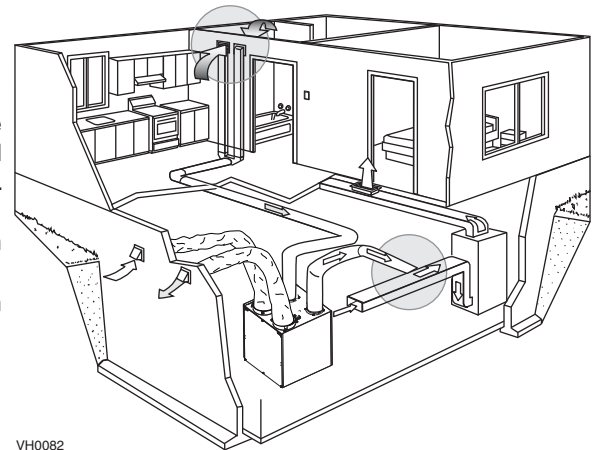

3.3 SIMPLIFIED INSTALLATION (CONNECTION TO A FORCED AIR SYSTEM)

Stale air is exhausted to the outside. Fresh air from outside is filtered and supplied to the return (plenum) or the supply duct of the forced air unit. See figure at right.

To avoid cross-contamination and achieve the highest efficiencies, the forced air system blower must always be ON.

NOTE: Home with multiple forced air systems should have one unit on each system.

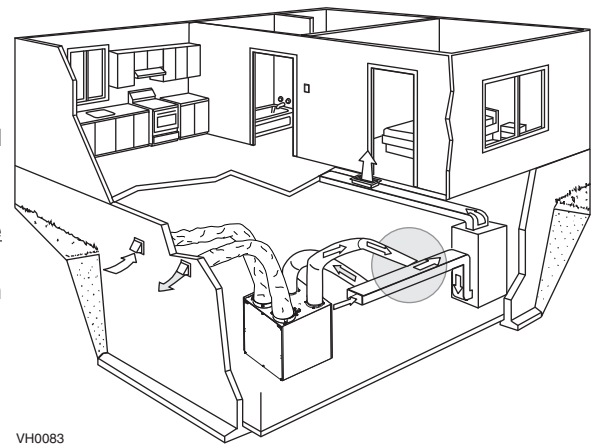

4. INSTALLATION

4.1 INSPECT THE CONTENT OF THE BOX

Inspect the exterior of the unit for shipping damage. Ensure that there is no damage to the door, ports, power cord, etc.

4.2 LOCATING THE UNIT

Choose an appropriate location for the unit.

- Within an area of the house **where the ambient temperature is kept between 10°C (50°F) and 40°C (104 °F)**.
- Away from living areas (dining room, living room, bedroom), if possible.
- So as to provide easy access to the interior of the unit, for quarterly and annual maintenance.
- Close to an exterior wall, so as to limit the length of the insulated flexible duct to and from the unit.
- Away from hot chimneys and other fire hazards.
- Allow for a power source (standard 3-prong grounding outlet).
- Close to a drain (HRV units only). If no drain is close by, use a pail to collect run-off.

Hang the unit with the four chains and springs provided. See illustration beside.

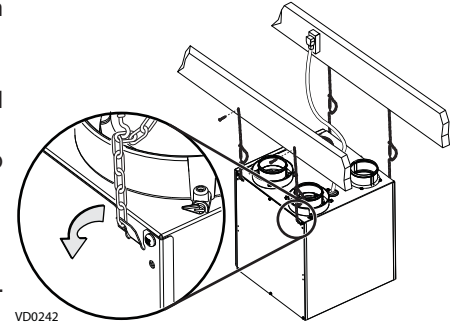

CAUTION

Make sure the unit is level.

4.3 PLANNING OF THE DUCTWORK

- Keep it simple. Plan for a minimum of bends and joints.
- Keep the length of insulated ducts to a minimum.
- Do not ventilate crawl spaces or cold rooms. Do not attempt to recover the exhaust air from a dryer or a range hood. This would cause clogging of the filters and recovery module.
- If the house has two floors or more, be sure to plan for at least one exhaust register on the highest lived-in level.

4.4 INSTALLING THE DUCTWORK AND REGISTERS

4.4.1 FULLY DUCTED SYSTEM (AS ILLUSTRATED IN SECTION 3.1)

WARNING

Never install a stale air exhaust register in a closed room where a combustion device operates, such as a gas furnace, a gas water heater or a fireplace.

Stale air exhaust ductwork

- Install the stale air exhaust registers where the contaminants are produced: kitchen, living room, etc. Position the registers as far from the stairway as possible and in such a way that the air circulates in all the lived-in spaces in the house.
- If a register is installed in the kitchen, it must be located at least 4 feet (1.2 m) from the range.
- Install the registers 6 to 12 inches (152 to 305 mm) from the ceiling on an interior wall OR install them in the ceiling.

Fresh air distribution ductwork

- Install the fresh air distribution registers in bedrooms, dining rooms, living room and basement.
- Keep in mind that the fresh air registers must be located as far as possible from the stale air registers.
- Install the registers either in the ceiling or high on the walls with air flow directed towards the ceiling. (The cooler air will then cross the upper part of the room and mix with room air, before descending to occupant's level.)
- If a register must be floor installed, direct the airflow up the wall.

4. INSTALLATION (CONT'D)

4.4 INSTALLING THE DUCTWORK AND REGISTERS (CONT'D)

4.4.2 CENTRAL DRAW POINT (AS ILLUSTRATED IN SECTION 3.2)

Stale air exhaust ductwork

Same as for Fully Ducted System, described on point 4.4.1

⚠ WARNING

When performing duct connections, always use approved tools and materials. Respect all corresponding laws and safety regulations. Please refer to your local building code.

CAUTION

When performing duct connections to the furnace supply duct, this duct must be sized to support the additional airflow produced by the unit. Also, the use of metal duct is highly recommended.

Fresh air distribution ductwork

There are 2 methods for connecting the unit to the furnace/air handler:

Method 1: Supply side connection

- Cut an opening into the furnace supply duct at least 18 inches (0.5 m) from the furnace/air handler.
- Connect this opening to the **Fresh air distribution** port of the unit (use **metal duct**, see figure beside).
- Make sure the unit duct forms an elbow inside the furnace/air handler ductwork.
- If desired, interlock (synchronize) the furnace/air handler blower operation (see Section 6 Electrical Connection to the Furnace).

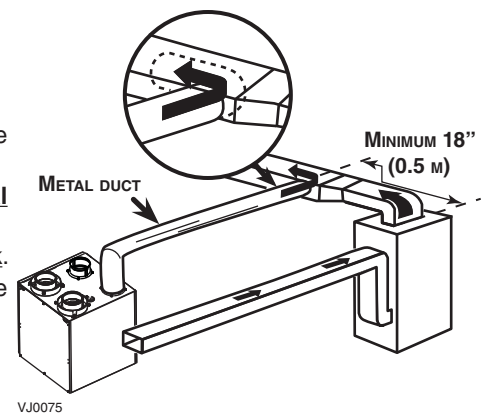

Method 2: Return side connection

- Cut an opening into the furnace return duct not less than 10 feet (3.1 m) from the furnace/air handler (A+B).
- Connect this opening to the **Fresh air distribution** port of the unit (see figure beside).

NOTE: For Method 2, it is not essential that the furnace/air handler runs when the unit is operation, but we recommend it. If desired, interlock (synchronize) the furnace/air handler blower operation (see Section 6 Electrical Connection to the Furnace).

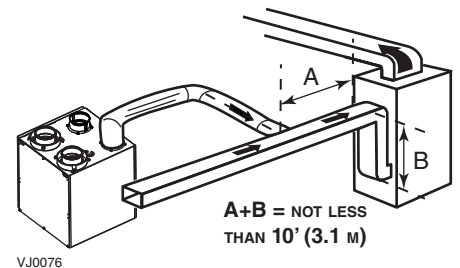

4. INSTALLATION (CONT'D)

4.4 INSTALLING THE DUCTWORK AND REGISTERS (CONT'D)

4.4.3 SIMPLIFIED INSTALLATION (AS ILLUSTRATED IN SECTION 3.3)

⚠ WARNING

When performing duct connections, always use approved tools and materials. Respect all corresponding laws and safety regulations. Please refer to your local building code.

CAUTION

When performing duct connections to the furnace supply duct (Method 1), this duct must be sized to support the additional airflow produced by the unit. Also, the use of metal duct is highly recommended. For a Return-Return installation, the furnace blower must be in operation when the unit is in operation.

There are 2 methods for connecting the unit to the furnace/air handler:

Method 1: Supply-Return Connection

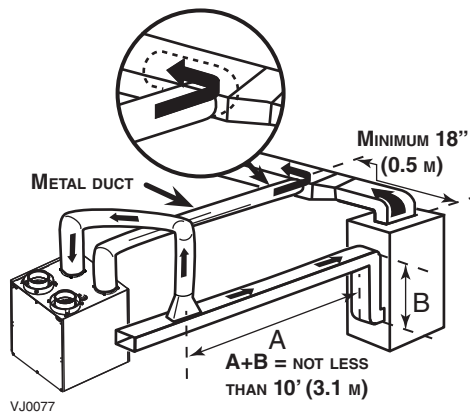

Method 2: Return-Return Connection

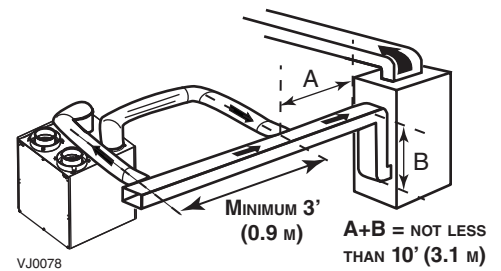

Stale air intake

- Cut an opening into the furnace return duct not less than 10 feet (3.1 m) from the furnace/air handler (A+B).
- Connect this opening to the **Exhaust air from building** port of the unit.

Fresh air distribution

- Same instructions as for Method 1 or Method 2, Section 4.4.2.
For Method 2 (Return-Return), make sure there is a distance of at least 3 feet (0.9 m) between the 2 connections to the furnace/air handler.

CAUTION

If using Method 2, make sure the furnace/air handler blower operation is synchronized with the unit operation! See Section 6 Electrical Connection to the Furnace.

NOTE: For Method 1, it is not essential to synchronize the furnace blower operation with the unit operation, but we recommend it.

4. INSTALLATION (CONT'D)

4.5 CONNECTING THE DUCTS TO THE UNIT

NOTE: All units ports were created to be connected to ducts having a minimum of 4" diameter, but if need be, they can be connected to bigger sized ducts by using an appropriate transition (e.g.: 4" diameter to 5" diameter transition).

Insulated flexible ducts

Use the following procedure to connect the insulated flexible ducts to the ports of the unit (**Exhaust air to outside** and **Fresh air from outside** ports).

All units have those 2 ports equipped with integrated balancing damper. Prior to install the insulated flexible ducts, ensure these both ports have their damper entirely open (their adjustment pin (A) must be set vertical, as shown beside).

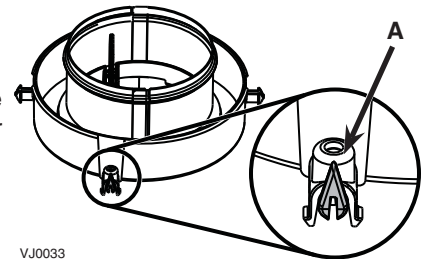

VJ0033

CAUTION

If ducts have to go through an unconditioned space (e.g.: attic), always use insulated ducts.

1. Pull back the insulation to expose the flexible duct.
2. Attach the flexible duct to the port using tie wrap.
3. Pull the insulation over the joint and tuck in between the inner and outer rings of the double collar.
4. Pull down the vapor barrier (shaded part in illustrations below) over the outer ring to cover it completely. Fasten in place the vapor barrier using the port strap included in unit parts bag). To do so, insert one collar pin through vapor barrier and first strap hole, then insert the other collar pin through vapor barrier and center strap hole and close the loop by inserting the first collar pin in the last strap hole.

CAUTION

Make sure the vapor barrier on the insulated ducts does not tear during installation to avoid condensation within the ducts.

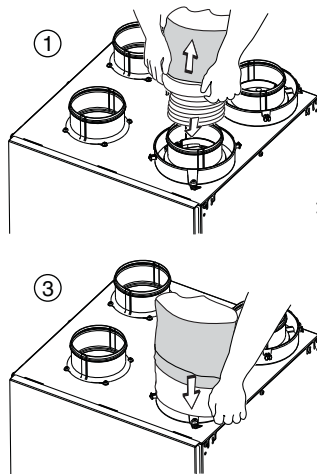

VJ0074

Non-insulated rigid ducts

Use metal screws and duct tape to connect the rigid ducts to the unit ports.

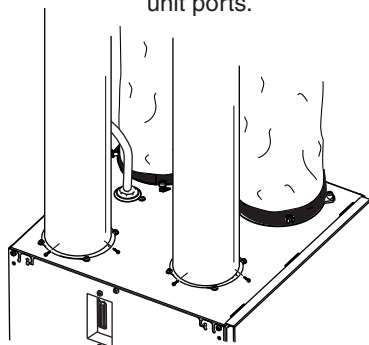

VJ0073

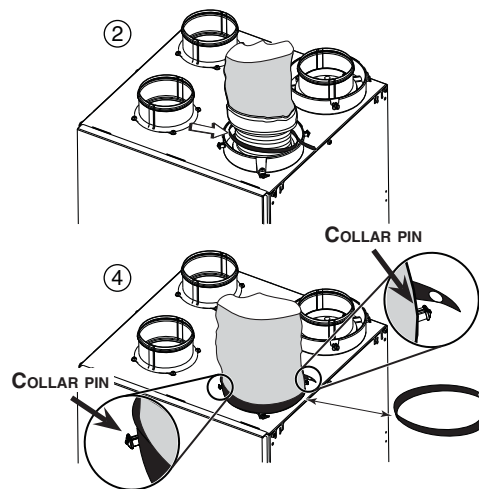

Non-insulated flexible ducts

Use tie wraps to connect the flexible ducts to the unit ports.

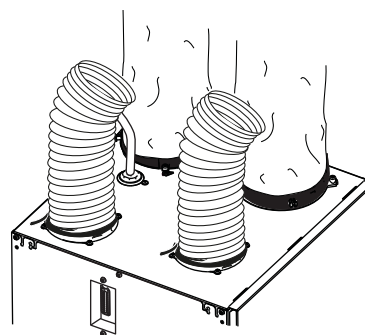

4. INSTALLATION (CONT'D)

4.6 INSTALLING TWO EXTERIOR HOODS

Choose an appropriate location to install the exterior hoods:

- There must be a minimum distance of 6 feet (1.8 m) between the hoods to avoid cross-contamination
- There must be a minimum distance of 18 inches (457 mm) from the ground

⚠ WARNING

Make sure the intake hood is at least 6 feet (1.8 m) away from any of the following:

- Dryer exhaust, high efficiency furnace vent, central vacuum vent
- Gas meter exhaust, gas barbecue-grill
- Any exhaust from a combustion source
- Garbage bin and any other source of contamination

Refer to figure beside for connecting insulated ducts to the exterior hoods. An "Anti-gust intake hood" should be installed in regions where a lot of snow is expected to fall.

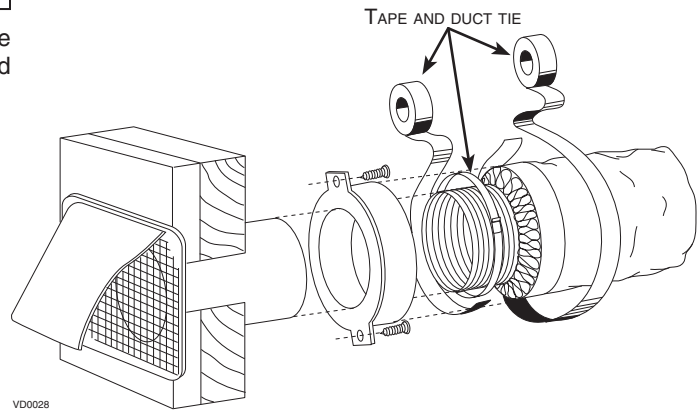
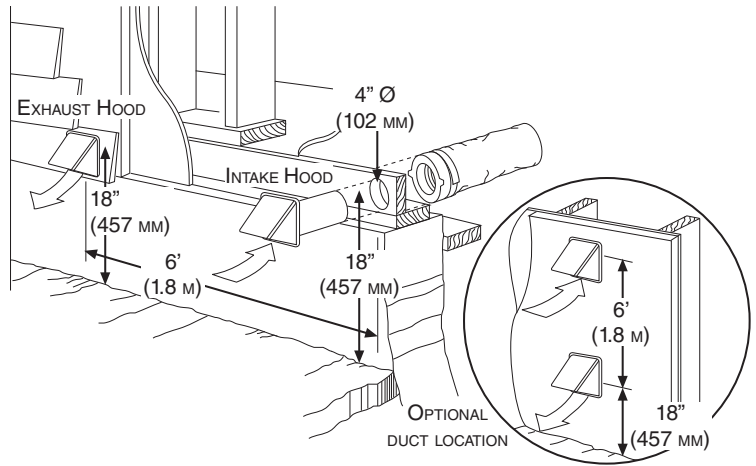

VD0028

4.7 INSTALLING SINGLE EXTERIOR HOOD USING TANDEM®* TRANSITION KIT (OPTIONAL)

The joist opening needed to install the Tandem® transition must be 9¾" minimum. The maximum height of the Tandem® transition is 8¾".

To connect 4" insulated flexible ducts to the 5" oval ends of the Tandem® transition (*Exhaust air to outside and Fresh air from outside*), connect an adapter to the Tandem® transition (not included).

For each duct connection:

1. Slightly squeeze a section of 4" round metal duct, at least 8" long, to insert it into the oval opening of the Tandem® transition and push it all the way in.
2. Using silicon, seal the joint between the outside of metal duct and Tandem® transition, and allow silicon to dry completely.

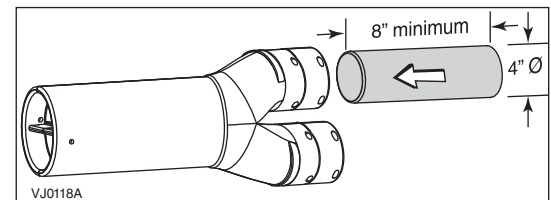

VJ0118A

CAUTION

When connecting insulated flexible duct to the Tandem® transition, pull the interior flexible duct over the adapter all the way to the silicon joint and secure using a tie wrap. Then pull the insulation over the joint, making sure that no part is left without insulation.

3. From this point on, follow the instructions included with the Tandem® transition kit (part no. 14690).

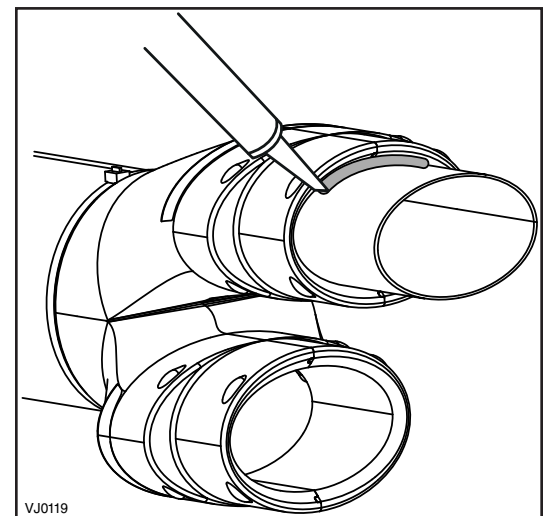

VJ0119

*Patented.

4. INSTALLATION (CONT'D)

4.8 CONNECTING THE DRAIN

CAUTION

A drain tubing (included) must be installed for all HRV units. For ERV units, it is not required, however, it is recommended for climates where the outside temperature typically remains below -25°C (-13°F), (over a 24-hour period) for several days in a row, combined with an indoor humidity of 40% or higher.

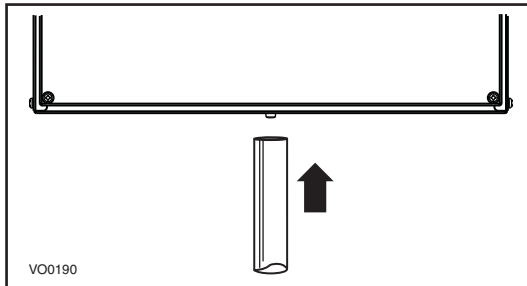

Connect the plastic tube to the inner drain fitting located under the unit as shown.

NOTE: For ERV units, remove drain plug outside the unit prior to install tubing.

Make a water trap loop in the tube to prevent the unit from drawing unpleasant odors from the drain source. Run the tube to the floor drain or to an alternative drain pipe or pail.

IMPORTANT

If using a pail to collect water, locate the tube end approximately 1" from the top of the pail in order to prevent water from being drawn back up into the unit.

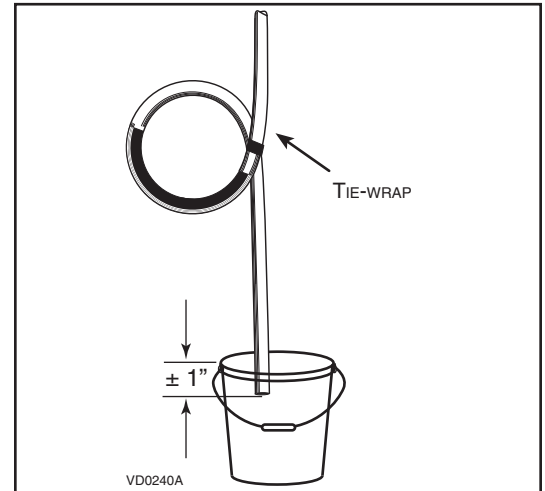

5. CONTROLS

All units are equipped with an integrated control located on upper left side of the unit. Plug the unit.

5.1 BOOTING SEQUENCE

The unit booting sequence is similar to a personal computer boot sequence. Each time the unit is plugged after being unplugged, or after a power failure, the unit will perform a 30-second booting sequence before starting to operate.

During the booting sequence, the integrated control LED will light GREEN for 5 seconds, and then will turn RED. During this RED light phase, the unit is checking and resetting the motorized damper position. Once the motorized damper position completely set, the RED light turns off and the booting sequence is done.

NOTE: No command will be taken until the unit is fully booted.

5.2 INTEGRATED CONTROL

Use the push button (1) to control the unit. The LED (2) will then show on which mode the unit is in.

Refer to table below to see how to operate the unit using its integrated control.

| PRESS ON PUSH BUTTON | LED COLOR | RESULTS |
|----------------------|-----------|-----------------------|
| ONCE | AMBER | UNIT IS ON LOW SPEED |
| TWICE | GREEN | UNIT IS ON HIGH SPEED |
| THREE TIMES | NO LIGHT | UNIT IS OFF |

If a problem occurs during the unit operation, its integrated control LED (2) will blink. The color of the blinking light depends on the type of error detected. Refer to Section 10 Troubleshooting on page 18 for further details.

NOTE: WHEN USING MAIN CONTROL, THE INTEGRATED CONTROL MUST BE TURNED OFF.

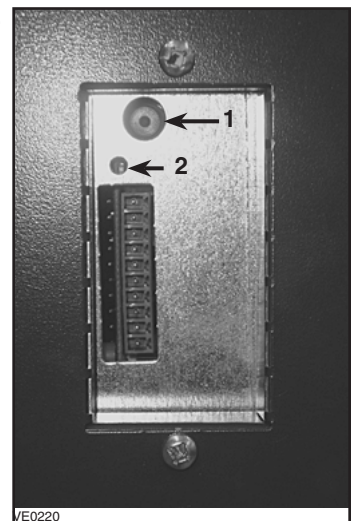

5. CONTROLS (CONT'D)

5.3 SETTING EXTENDED DEFROST

These units are factory set to normal defrost. In cold region (outside temperature -27°C [-17°F] and lower), it may be necessary to setup extended defrost. During the first 2 seconds of booting sequence, while the integrated control LED is GREEN, press on push button for 3 seconds to set the unit in extended defrost; the LED will blink AMBER to show the unit is in extended defrost mode. After that, the LED will shut off, then light RED (the unit returns in its booting sequence).

5.4 ELECTRICAL CONNECTION TO MAIN CONTROLS

For more convenience, these units can also be controlled using an optional main wall control.

NOTES: 1. The integrated control must be turned OFF to use an optional main control.

2. If an optional auxiliary control is used, if activated, this auxiliary control will override the optional main control.

⚠ WARNING

Always disconnect the unit before making any connections. Failure in disconnecting power could result in electric shock or damage of the wall control or electronic module inside the unit.

CAUTION

Never install more than one optional main wall control per unit. Make sure that the wires do not short-circuit between themselves or by touching any other components on the wall control. Avoid poor wiring connections. To reduce electrical interference (noise) potential, do not run wall control wiring next to control contactors or near light dimming circuits, electrical motors, dwelling/building power or lighting wiring, or power distribution panel.

Use the terminal connector included in the installation kit to perform the electrical connection for main and optional wall controls. Check if all wires are correctly inserted in their corresponding holes in the terminal block. (A wire is correctly inserted when its orange receptacle is lower than another one without wire. On picture beside, wire **A** is correctly inserted, but wire **B** is not.)

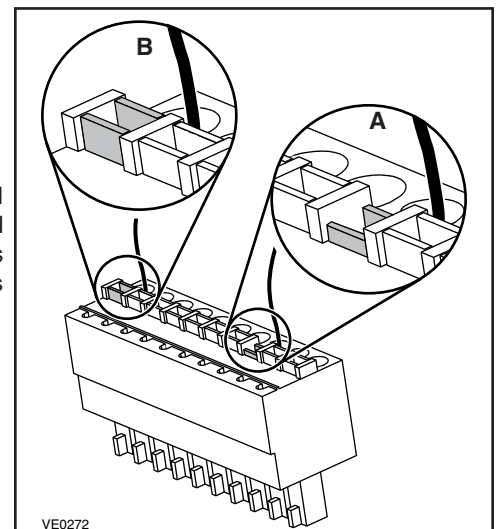

5. CONTROLS (CONT'D)

5.4 ELECTRICAL CONNECTION TO MAIN CONTROLS (CONT'D)

5.4.1 ELECTRICAL CONNECTION TO ALTITUDE (K7 ERV, K8 HRV AND K10 HRV UNITS ONLY) OR PLATINUM (40E, 40H+ AND 50H UNITS ONLY) MAIN WALL CONTROL

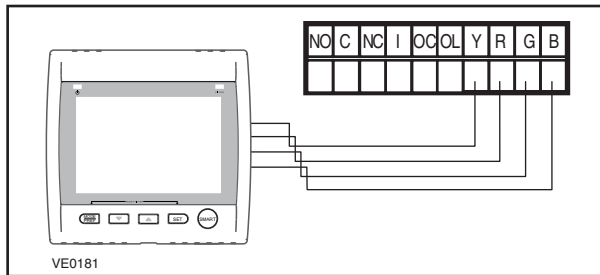

5.4.2 ELECTRICAL CONNECTION TO DECO-TOUCH MAIN WALL CONTROL (ALL UNITS)

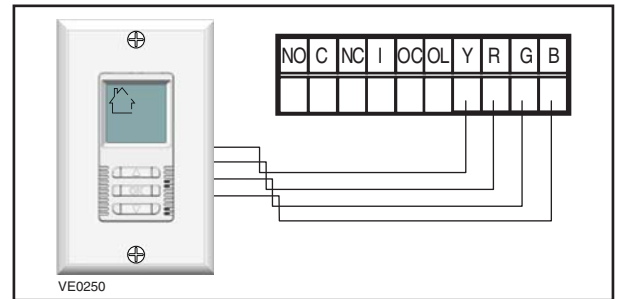

5.4.3 ELECTRICAL CONNECTION TO LITE-TOUCH CONSTRUCTO OR SIMPLE-TOUCH CONSTRUCTO MAIN WALL CONTROLS (K7 ERV, K8 HRV AND K10 HRV UNITS ONLY)

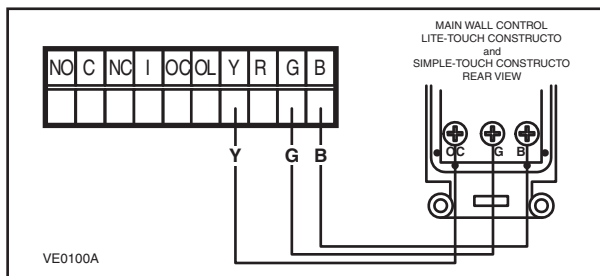

5.4.4 ELECTRICAL CONNECTION TO LITE-TOUCH BRONZE OR SIMPLE-TOUCH BRONZE MAIN WALL CONTROLS (40E, 40H+ AND 50H UNITS ONLY)

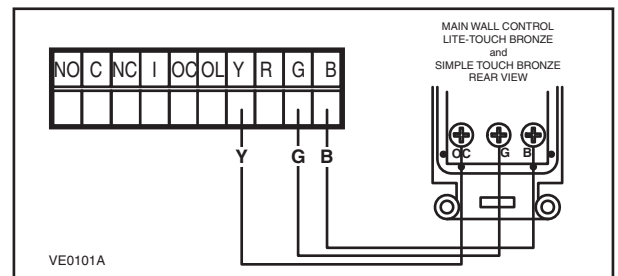

5.4.5 ELECTRICAL CONNECTION TO CONSTRUCTO MAIN WALL CONTROL (K7 ERV, K8 HRV AND K10 HRV UNITS ONLY)

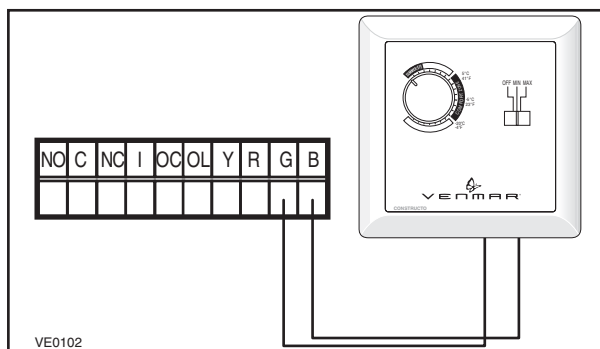

5.4.6 ELECTRICAL CONNECTION TO BRONZE MAIN WALL CONTROL (40E, 40H+ AND 50H UNITS ONLY)

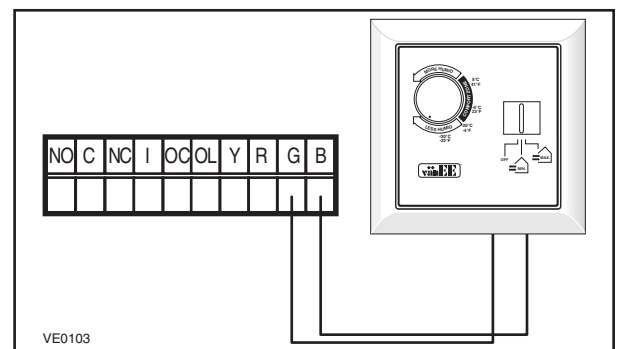

5. CONTROLS (CONT'D)

5.5 ELECTRICAL CONNECTION TO OPTIONAL AUXILIARY CONTROLS

NOTE: If the Dehumidistat is activated and then an optional auxiliary control is being activated, this one will override the Dehumidistat command.

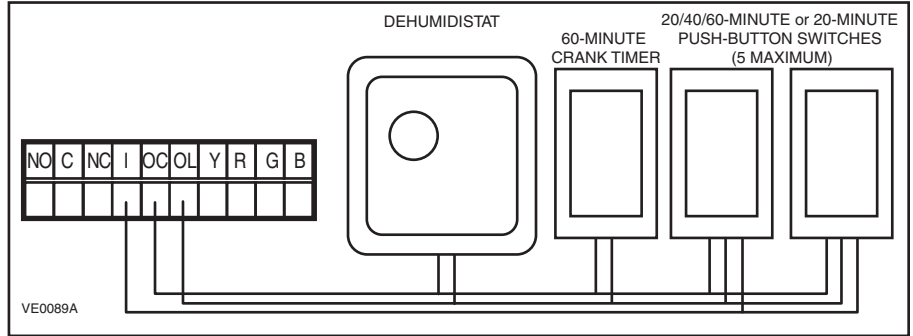

Once the control(s) connections have been made, insert the terminal connector in the electrical compartment interface.

NOTE: For information about the operation of the wall controls, refer to the user guide.

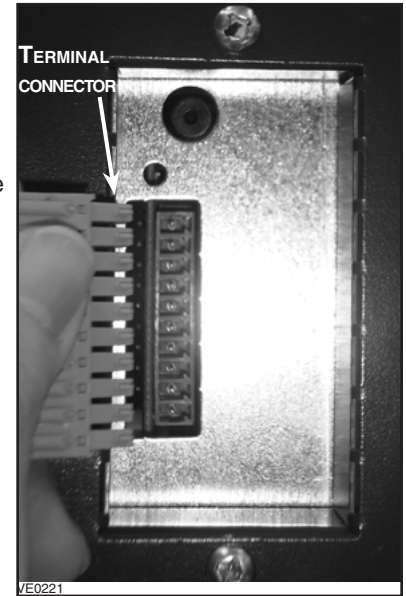

6. ELECTRICAL CONNECTION TO THE FURNACE

⚠ WARNING

Never connect a 120-volt AC circuit to the terminals of the furnace interlock (standard wiring). Only use the low voltage class 2 circuit of the furnace blower control.

For a furnace connected to a cooling system:

On some older thermostats, energizing the “R” and “G” terminals at the furnace has the effect of energizing “Y” at the thermostat and thereby turning on the cooling system. If you identify this type of thermostat, you must use the ALTERNATE FURNACE INTERLOCK WIRING.

STANDARD FURNACE INTERLOCK WIRING

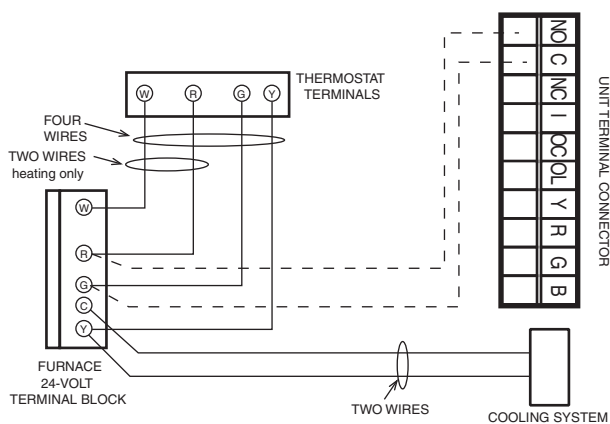

VE0108A

ALTERNATE FURNACE INTERLOCK WIRING

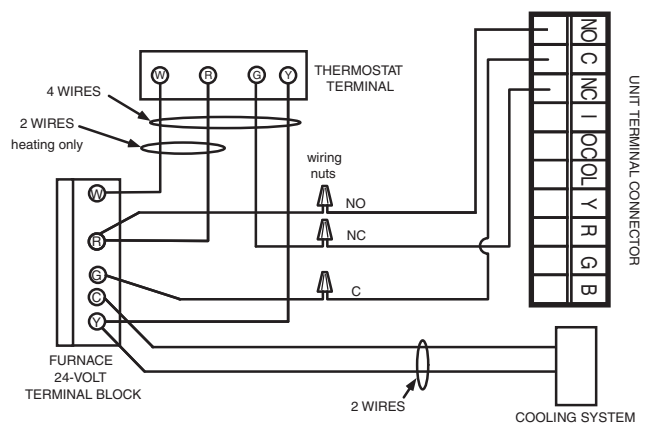

7. WIRING DIAGRAM

⚠ WARNING

- Risk of electric shocks. Before performing any maintenance or servicing, always disconnect the unit from its power source.
- This product is equipped with an overload protection (fuse). A blown fuse indicates an overload or a short-circuit situation. If the fuse blows, unplug the product from the outlet. Replace the fuse as per the servicing instructions (refer to wiring diagram for proper fuse rating) and verify the product. If the replaced fuse blows, it may be a short-circuit and the product must be discarded or returned to an authorized service center for examination and/or repair.

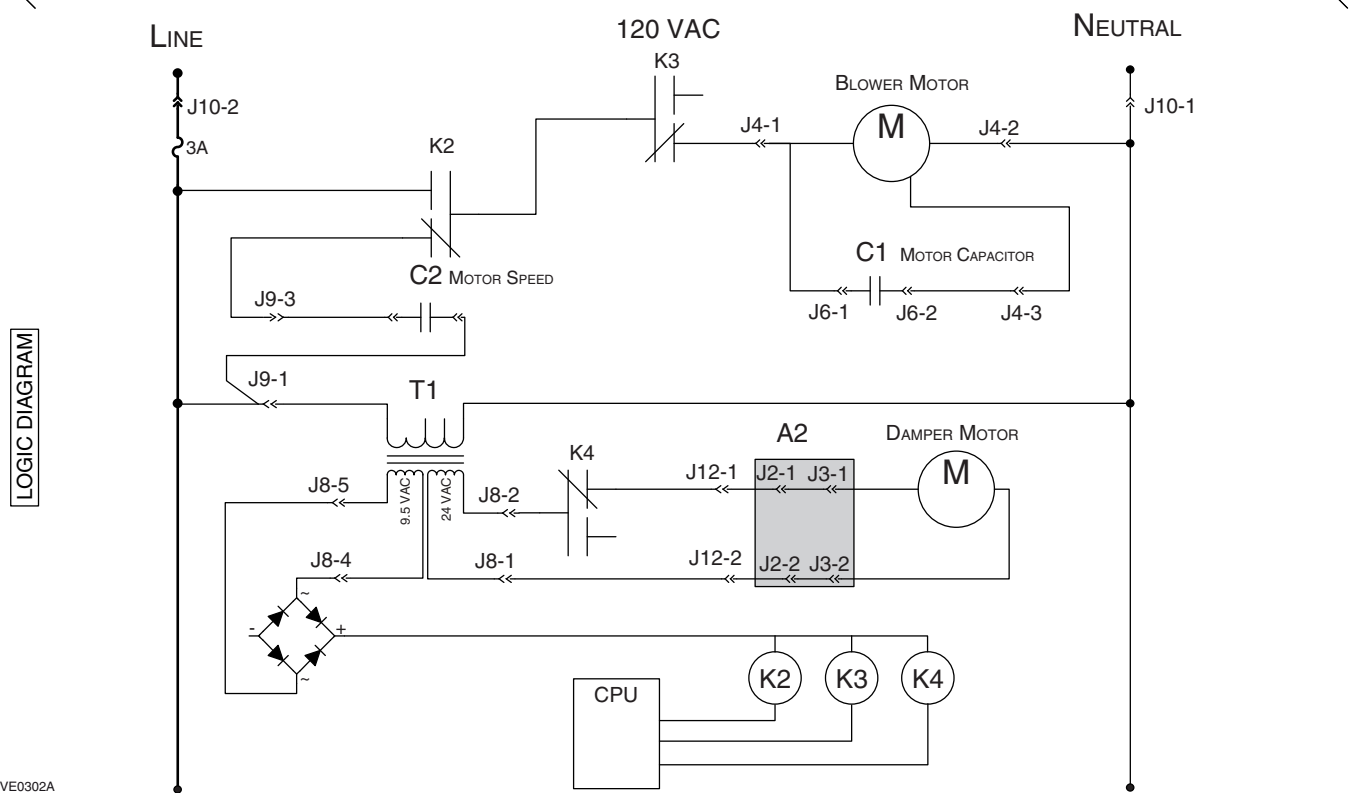
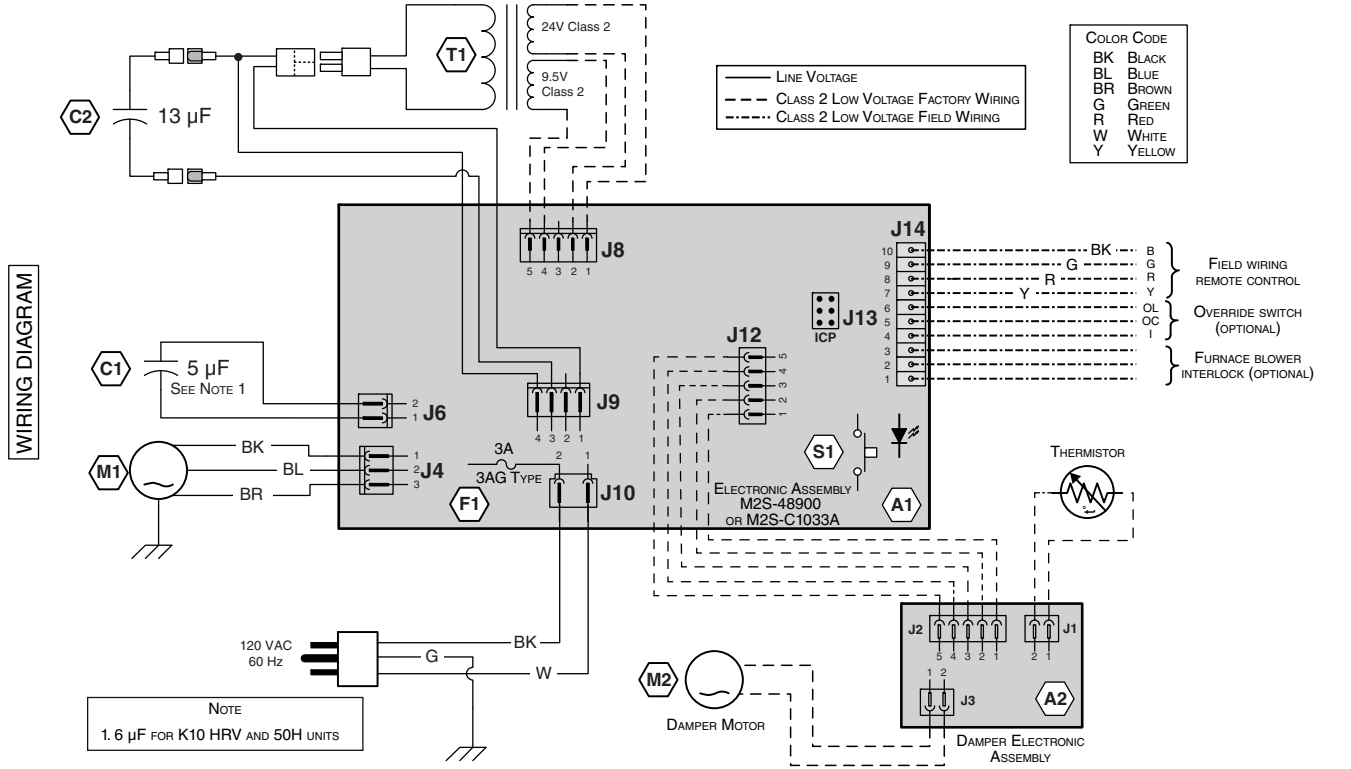

8. BALANCING THE UNIT

8.1 WHAT YOU NEED TO BALANCE THE UNIT

- A magnehelic gauge capable of measuring 0 to 0.5 inch of water (0 to 125 Pa) and 2 plastic tubes.
- The balancing chart of the unit, **located on the unit door.**

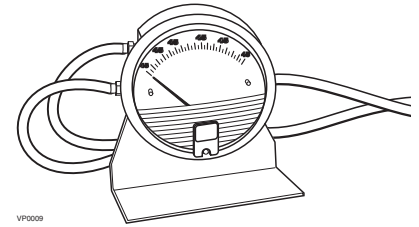

8.2 PRELIMINARY STAGES TO BALANCE THE UNIT

- Seal all the unit ductwork with tape. Close all windows and doors.
- Turn off all exhaust devices such as range hood, dryer and bathroom fans.
- Make sure the balancing dampers are fully open (their adjustment pin (A) must be set vertical, see illustration beside).
- Make sure all filters are clean (if it is not the first time the unit is balanced).

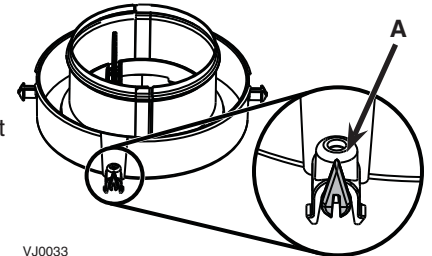

8.3 BALANCING PROCEDURE

1. Set the unit to high speed.

NOTE: Make sure that the furnace/air handler blower is ON if the installation is in any way connected to the ductwork of the cold air return. If not, leave furnace/air handler blower OFF. If the outside temperature is below 0°C/32°F, make sure the unit is not running in defrost while balancing. (By waiting 10 minutes after plugging the unit in, you are assured that the unit is not in a defrost cycle.)

2. Place the magnehelic gauge on a level surface and adjust it to zero.

3. Connect tubing from gauge to EXHAUST air flow pressure taps (see diagram on unit door).

Be sure to connect the tubes to their appropriate high/low fittings. If the gauge drops below zero, reverse the tubing connections.

4. Note the CFM value from balancing chart on unit.

5. Repeat steps 3 and 4, but to FRESH air flow pressure taps.

6. Match highest CFM value to lowest by adjusting the balancing damper corresponding to the highest value. To do so, rotate the adjustment pin.

See example below:

| PRESSURE | FRESH | EXHAUST |
|------------|-------|---------|
| IN. W.G. | CFM | CFM |
| 0.16 | 47 | 42 |
| 0.18 | 54 | 48 |
| 0.2 | 60 | 55 |
| 0.22 | 66 | 61 |
| 0.24 | 72 | 68 |
| 0.26 | 78 | 74 |
| 0.28 | 84 | 81 |
| 0.3 | 90 | 88 |

EXHAUST
READING
VALUES

FRESH
READING
VALUES

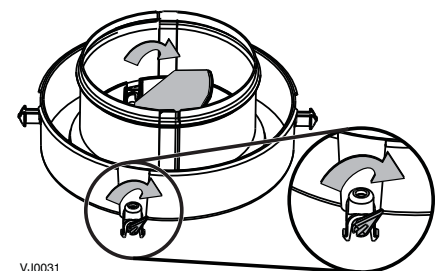
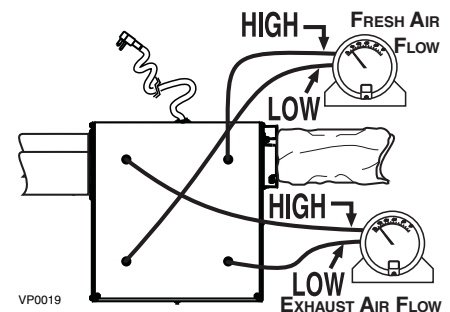

In that case, there is 78 CFM in FRESH air and 61 CFM in EXHAUST air. Then, using the adjustment pin, adjust (close) the FRESH air balancing damper until the FRESH air flow matches the EXHAUST air flow: 60 CFM (0.2 in. w.g.) with magnehelic gauge connected to FRESH air flow pressure taps).

7. Secure both dampers in place with a fastening screw (included in the hardware kit).

8. Write the required air flow information on a label and stick it near the unit for future reference (date, maximum speed air flows, your name, phone number and business address).

NOTES: 1. Use conversion chart provided with the unit to convert magnehelic gauge readings to equivalent cfm values.

2. The unit is considered balanced even if there is a difference of ± 10 cfm (or ± 5 l/s or 17 m³/h) between the two air flows.

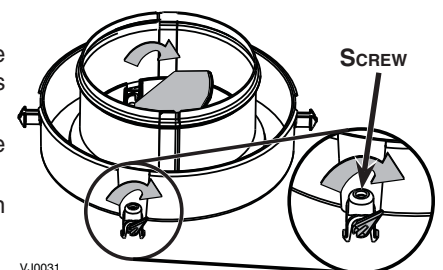

9. SERVICE PARTS

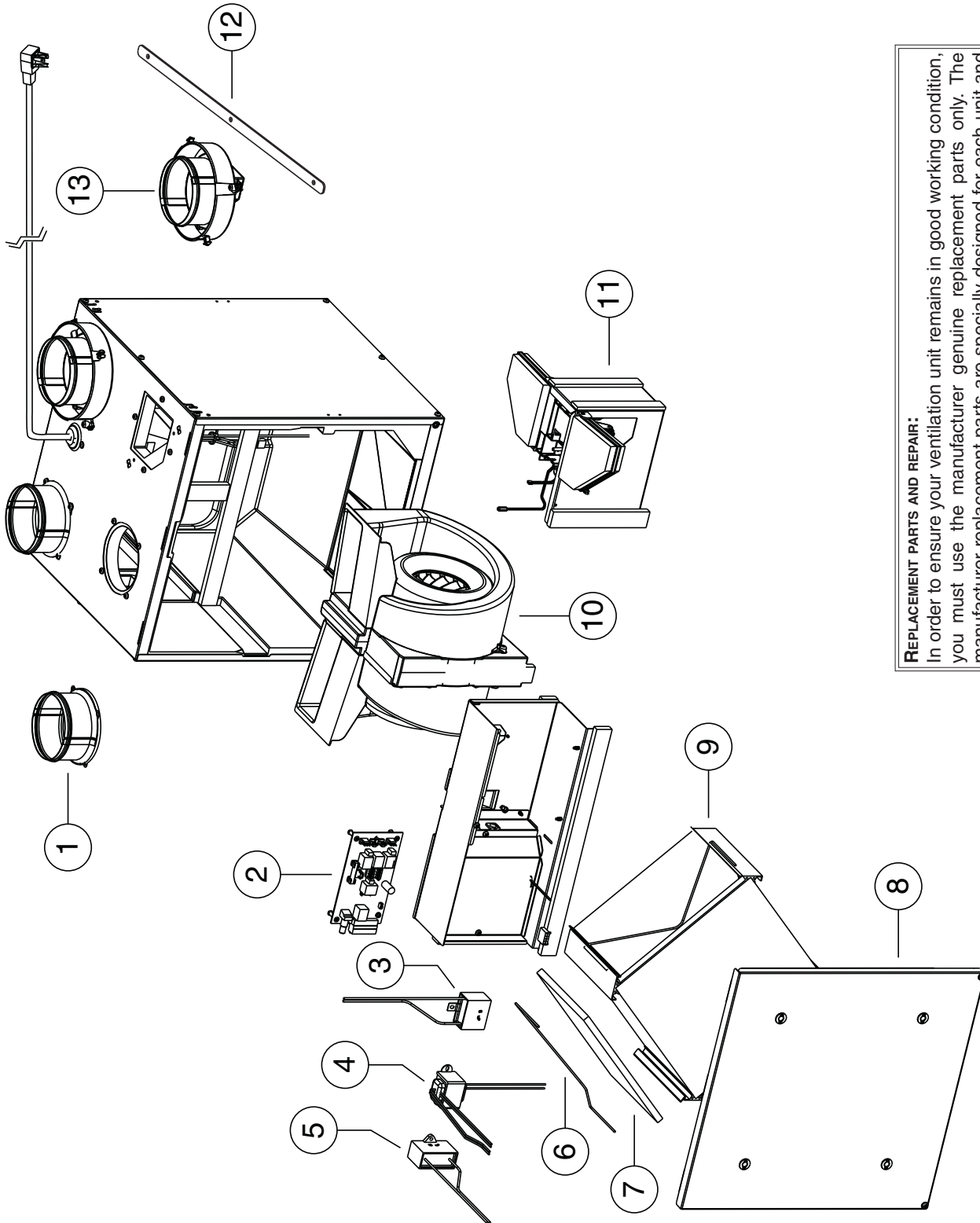

REPLACEMENT PARTS AND REPAIR:
 In order to ensure your ventilation unit remains in good working condition, you must use the manufacturer genuine replacement parts only. The manufacturer replacement parts are specially designed for each unit and are manufactured to comply with all the applicable certification standards and maintain a high standard of safety. Any third party replacement part used may cause serious damage and drastically reduce the performance level of your unit, which will result in premature failing. The manufacturer recommends to contact a certified service depot for all replacement parts and repair.

VL0043

9. SERVICE PARTS (CONT'D)

| ITEM | PART No. | DESCRIPTION | K8 HRV (44152) | K8 HRV (44153) | K7 ERV (44162) | K7 ERV (44163) | 40H+ (44252) | 40H+ (44253) | 40E (44262) | 40E (44263) | K10 HRV (44500) | K10 HRV (44502) | 50H (44600) | 50H (44602) |
|------|----------|-----------------------------------|----------------|----------------|----------------|----------------|--------------|--------------|-------------|-------------|-----------------|-----------------|-------------|-------------|
| 1 | 18854 | 4" ROUND METAL PORT | 2 | 2 | 2 | 2 | 2 | 2 | 2 | 2 | 2 | 2 | 2 | 2 |
| 2 | 19206 | ELECTRONIC BOARD (HRV) | 1 | 1 | | | 1 | 1 | | | 1 | 1 | 1 | 1 |
| | 19207 | ELECTRONIC BOARD (ERV) | | | 1 | 1 | | | 1 | 1 | | | | |
| 3 | 16042 | CAPACITOR 5 µF | 1 | 1 | 1 | 1 | 1 | 1 | 1 | 1 | 1 | 1 | 1 | 1 |
| | 61550 | CAPACITOR 6 µF | | | | | | | | | | | | |
| 4 | 17244 | TRANSFORMER | 1 | 1 | 1 | 1 | 1 | 1 | 1 | 1 | 1 | 1 | 1 | 1 |
| 5 | 19211 | CAPACITOR 13 µF | 1 | 1 | 1 | 1 | 1 | 1 | 1 | 1 | 1 | 1 | 1 | 1 |
| 6 | 19208 | FILTER RETAINING WIRES (PAIR) | 1 | 1 | 1 | 1 | 1 | 1 | 1 | 1 | 1 | 1 | 1 | 1 |
| 7 | 18883 | CORE FILTERS (PAIR) | 1 | 1 | 1 | 1 | 1 | 1 | 1 | 1 | 1 | 1 | 1 | 1 |
| | 19201 | DOOR ASSEMBLY | 1 | 1 | 1 | 1 | | | | | 1 | 1 | | |
| 8 | 19203 | DOOR ASSEMBLY | | | | | 1 | 1 | 1 | 1 | | | 1 | 1 |
| | 19199 | HEAT RECOVERY CORE | 1 | 1 | | | 1 | 1 | | | 1 | 1 | 1 | 1 |
| 9 | 19200 | ENERGY RECOVERY CORE | | | 1 | 1 | | | 1 | 1 | | | | |
| | 18867 | BLOWER ASSEMBLY | 1 | 1 | 1 | 1 | 1 | 1 | 1 | 1 | | | | |
| 10 | 62176 | BLOWER ASSEMBLY | | | | | | | | | 1 | 1 | 1 | 1 |
| | 18868 | VERTICAL PORTS DAMPER SYSTEM | 1 | | 1 | | 1 | | 1 | | 1 | | 1 | |
| 11 | 18881 | HORIZ. PORTS DAMPER SYSTEM* | | 1 | | 1 | | | | 1 | | 1 | | 1 |
| | 19212 | 4" PORTS STRAPS | 2 | 2 | 2 | 2 | 2 | 2 | 2 | 2 | 2 | 2 | 2 | 2 |
| 13 | 18855 | 4" DOUBLE COLLAR PORT WITH DAMPER | 2 | 2 | 2 | 2 | 2 | 2 | 2 | 2 | 2 | 2 | 2 | 2 |
| 14 | 19213 | HARDWARE KIT* | 1 | 1 | 1 | 1 | 1 | 1 | 1 | 1 | 1 | 1 | 1 | 1 |
| 15 | 16416 | PCB CONNECTOR* | 1 | 1 | 1 | 1 | 1 | 1 | 1 | 1 | 1 | 1 | 1 | 1 |



* PART NOT SHOWN.

10. TROUBLESHOOTING

If the unit does not work properly, reset the unit by unplugging it for one minute and then replug it. If it still not working properly, refer to table below.

If the integrated control LED of the unit is flashing, this means the unit sensors detected a problem. See the table below to know where the problem occurs on the unit.

| LED Signal | Error Type | Action | Unit Status |
|-------------------|------------------|------------------------|--|
| LED flashes GREEN | Thermistor error | Replace damper system. | Unit works but will defrost frequently |
| LED flashes AMBER | Damper error | Go to point 6 | Unit does not work |

| | Problems | Possible causes | You should try this |
|---|---|--|--|
| 1 | The error code E1 is displayed on Altitude, Platinum or Deco-Touch wall control screen. | <ul style="list-style-type: none"> The wires may be in reverse position. The wires may be broken. The wires may have a bad connection. | <ul style="list-style-type: none"> Ensure that the color wires have been connected to their appropriate places. Inspect every wire and replace any that are damaged. Ensure the wires are correctly connected. |
| 2 | There is no outside temperature displayed on Altitude or Platinum wall control screen   . | <ul style="list-style-type: none"> The unit thermistor is defective (the integrated control LED of the unit must flash GREEN). | <p>NOTE: At its very start-up or after a power failure, it takes some minutes before the outside temperature appears on screen. The shortest delay is obtained when the wall control is set on MIN or MAX in VENT Mode.</p> <ul style="list-style-type: none"> Replace the unit damper system. |
| 3 | Altitude, Platinum or Deco-Touch wall control screen alternates between normal display and E3. | <ul style="list-style-type: none"> The Altitude, Platinum or Deco-Touch wall control may be defective. | <ul style="list-style-type: none"> Replace the Altitude, Platinum or Deco-Touch wall control. |
| 4 | On Altitude or Platinum wall control, there is an important difference between temperature displayed and real temperature. | <ul style="list-style-type: none"> The unit thermistor is defective. The unit damper has been blocked or broken. | <ul style="list-style-type: none"> Replace the unit thermistor. Check for the proper operation of the unit damper; replace if necessary. |
| 5 | Unit does not work. | <ul style="list-style-type: none"> The circuit board may be defective. The fuse may be defective. | <ul style="list-style-type: none"> Unplug the unit. Disconnect the main control and the optional(s) control(s) (if need be). Jump G and B terminals. Plug the unit back and wait about 10 seconds. If the motors run on high speed and the damper opens, the circuit board is not defective. Check if fuse F1 (located on PCB) is blown. In that case, replace fuse F1 as per wiring diagram specifications. |
| 6 | The wall control does not work. | <ul style="list-style-type: none"> Unit integrated control set to low or high speed (AMBER or GREEN continuous LED). Unit not compatible with control. The wires may be in reverse position. The wires may be misconnected. The wires may be broken. Defective wall control. | <ul style="list-style-type: none"> Press on the integrated push button until the LED turns off. Check table on page 2 for control compatibility. Ensure that the color coded wires have been connected to their appropriate places. Ensure the wires are correctly connected. Inspect every wire and replace any that are damaged. Replace the wall control. |

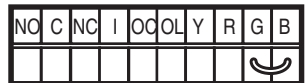

VE0097

10. TROUBLESHOOTING (CONT'D)

| | Problems | Possible causes | You should try this |
|---|---|---|---|
| 7 | The damper system does not work (AMBER error code). | <p>At power up, no RED LED. At power up, LED lights RED and there is a clicking sound coming from electrical compartment, but damper does not move:</p> <ul style="list-style-type: none"> Ice or other things hindering the damper movement. J12 unconnected or bad contact. Wrong connection of J8. The transformer may be defective (no 24 VAC between J8-1 and J8-2). The damper actuator may be defective. <p>Damper moves but does not stop when supposed to:</p> <ul style="list-style-type: none"> Damper motor turns on reverse side. Bad connection of J12 connector. Damper PCB defective or damper motor stripped gear. The main PCB is defective. | <ul style="list-style-type: none"> See point 5. Remove ice or hindering elements. Check J12 connection (both harness side and board side). Check J8 connection. With unit powered and J9 connected, check if there is about 20-24 VAC between transformer connector J8-1 and J8-2 (ORANGE wires). If no, change the transformer. Replace the damper system. Facing the damper motor shaft, the motor should turn counterclockwise. If not, replace the damper system. Check J12 connection (both harness side and board side). Replace the damper system. Replace the main PCB. |
| 8 | The Dehumidistat does not work OR other optional auxiliary control does not work OR its indicator light does not stay on. | <ul style="list-style-type: none"> The wires may be in reverse position. The wires may be misconnected. The wires may be broken. The Dehumidistat or push button may be defective. | <ul style="list-style-type: none"> Ensure that the color coded wires have been connected to their appropriate places. Ensure the wires are correctly connected. Inspect every wire and replace any that is damaged. If wires are hidden into walls, test the control using a shorter wire. Jump the OL and OC terminals. If the unit switch to high speed, remove the  <p>VE0098</p> <ul style="list-style-type: none"> Dehumidistat or push button and test it right beside the unit using another shorter wire. If it works here, change the wire. If it doesn't, change the Dehumidistat or the push button. |
| 9 | The blower motor does not work. | <ul style="list-style-type: none"> The fuse may be defective. The motor or capacitor may be defective. <p>NOTE: The unit must be unplugged to perform this test.</p> | <ul style="list-style-type: none"> Check if fuse F1 (located on PCB) is blown. In that case, replace fuse F1 as per wiring diagram specifications. Using a multimeter, check the ohms value on motor connector. For BLUE and BLACK motor wires, the right value is ± 68 ohms. For BLUE and BROWN motor wires, the right value is ± 58 ohms. For BROWN and BLACK motor wires, the right value is ± 126 ohms. If the ohms values are the same, the motor is not defective. Replace the motor capacitor. |