

WhisperFit-Warm™

VENTILATION FAN

FV-07VFH3

Low profile fan/heater solution for small bathrooms

- Ideal for remodeling and simple installation in small bathrooms
- Low profile housing design fits in 2" x 6" construction
- Aerodynamic fan design delivers whisper quiet operation
- 1 minute warm-up quickly heats up a cold room
- Detachable filter removes dust from exhaust air and is easy to clean
- 1300 Watt temperature regulating PTC* heater ensures safety and reliability

* PTC (Positive Temperature Coefficient) heating elements are small ceramic stones with self-limiting temperature characteristics. PTC stones have fast heating response times and level out once a pre-defined temperature is reached.

Additional Benefits

- Fully enclosed condenser motor for long life rated for 30,000 hours continuous run
- Thermal fuse protection on motor and 3-level safety device for heater
- Built-in damper to prevent back draft
- 4" duct adapter included
- 3 Year Warranty on parts



Panasonic

WhisperFit-Warm™ Ventilation Fans

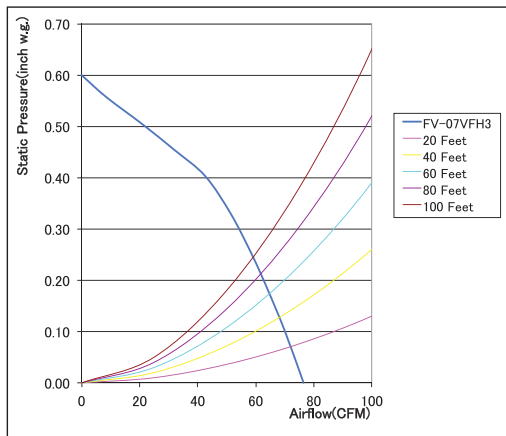
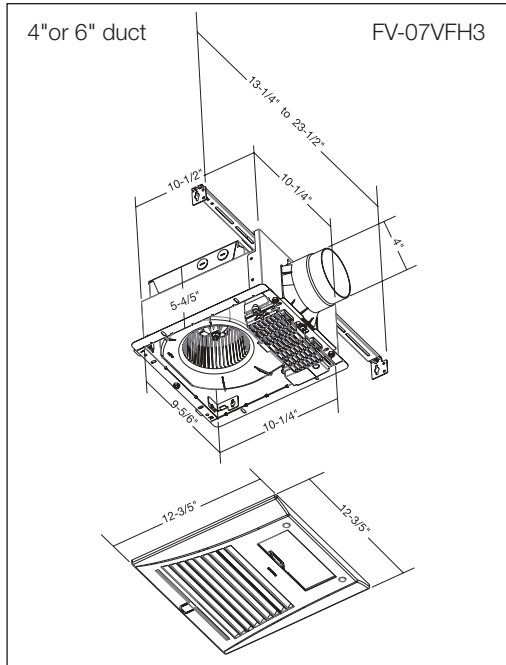

WhisperFit-Warm		FV-07VFH3	
Characteristics (HVI tested data for 0.1" S.P.)	Static Pressure in inches w.g.	0.1	0.25
	Air Volume (CFM)	70	59
	Noise (sones)	1.5	2.2
	Power Consumption (watts)	26.2	26.1
	Energy Efficiency (CFM/Watt)	2.7	2.3
	Speed (RPM)	1135	1305
	Current (amps)	0.17	0.17
	MAX. Current(amps)	0.22	
	Power Rating (V/Hz)	120/60	
Specifications	Motor Type	AC	
	Type of Motor Bearing	Ball	
	Thermal Fuse Protection	Yes	
	Blower Wheel Type	Sirocco	
	ENERGY STAR Qualified	No	
Installation	Duct Diameter (Inches)	4"	
	Mounting Opening (Inches sq.)	10-3/5"	
	Grille Size (Inches sq.)	12-3/5"	
Heater	PTC Heater	Yes	
	Directional Louver	N/A	
	Heating Element (Watts)	1,300	
Shipping	Gross Weight (lbs)	11.2	
Approved Code/ Standard/Regulation	UL tub/Shower Enclosure	N/A	
	Washington VIAQ Code	Yes	
	California Title 24 Compliant	Yes	
	Mfg in ISO 9001 Certified Facility	Yes	



Printed with soy ink on 10% post-consumer recycled paper.

Panasonic Eco Solutions North America Eco Products Division

One Panasonic Way, 1H-3
Secaucus, NJ 07094
(201) 348-7000

www.panasonic.com/building

For Distributor Order Information

PHONE: 866-292-7299
FAX: 888-553-0723

ventfans@us.panasonic.com

Design and specifications subject to change without notice.