

Installation Guide DELTA®-VENT SA



Flashing Systems for REBATE WINDOWS

Dörken – Leading Through Technical Competence

Dörken Systems Inc. (ISO 9001-2008) is a subsidiary of the Dörken Group that has over 100 years of experience in the construction industry. Developed from innovative ideas and manufactured on state-of-the-art production lines, the premium quality products for moisture management in building enclosures set standards for reliability, durability, and energy savings. Located in Beamsville, Ontario, Canada, Dörken provides customized solutions and products of outstanding quality. Dörken Systems Inc. is and always will be a trustworthy and highly respected partner for designers, architects, distributors and installers.

Contents

■ Introduction	3
■ Method Selection Guide	4
Strip-in method for rebate windows	6
■ 1. With DELTA®-FAS CORNER	6
■ 2. With flat sill	14
■ 3. With sloped sill	22
■ 4. With backdam	30
Cut-out method for rebate windows	38
■ 5. With DELTA®-FAS CORNER	38
■ 6. With flat sill	44
■ 7. With sloped sill	50
■ 8. With backdam	56
DELTA® Accessories	62
■ Appendix	66



Disclaimer: Substantial effort has been made to ensure that all data and information in this publication is accurate. Dörken System Inc. and RDH cannot accept responsibility of any errors or oversight in the use of material or in the preparation of architectural or engineering plans. The design professional must recognize that no design guide can substitute for experienced engineering and professional judgment. This publication is intended for use by professional personnel competent to evaluate the significance and limitations of its contents and able to accept responsibility for the application of the material it contains. Users are encouraged to offer comments to Dörken System Inc. and RDH on the content and suggestions for improvement. Questions concerning the source and derivation of any material in the design guide should be directed to Dörken System Inc. and RDH.

Prepared by:



Graham Finch, MASC, P.Eng
James Bourget, ABET, RRO
Robin Urquhart, MBSc, MA NRES
Dave Ricketts, MSc, P.Eng



Marcus Jablonka, Dipl. Ing., Dipl. Wirt. Ing.
Peter Barrett, B.A. (Hons), M.B.A.
Krzysztof Apiasz, C.Tech.

Introduction

DELTA®-VENT SA water-resistive barrier and air barrier

This Installation Guide covers the preparation of rough window openings with DELTA®-VENT SA Water-resistive Barrier and Air Barrier and its components.

The following diagrams present a step-by-step sequence for all installations. There are several options for these installation sequences. For example, window placement within the rough opening will depend on the rebate frame depth, the window manufacturer's specifications, and architectural considerations such as flashing and trim. All installations, regardless of variations, will follow the same fundamental approach.

The membrane's primary purpose is to function as a vapor permeable water-resistive barrier and continuous air barrier. Special attention is paid to interface areas to ensure that water or air cannot penetrate the assembly. Following the steps outlined in this Installation Guide will help ensure best practice installations.

These diagrams for DELTA®-VENT SA are intended only as a guide and are for the convenience of architects, specifiers, contractors and other interested parties. The final application and details are the sole responsibility of the design authority on record for the project.



Additional Technical and Installation Guides are available

Method Selection Guide

Strip-in methods for rebate windows

Rebate Windows

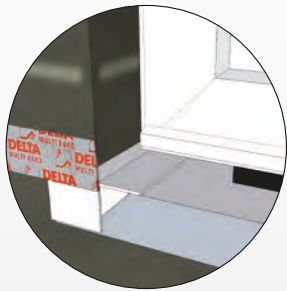

Strip-in method



1. DELTA®-FAS CORNER (page 6)

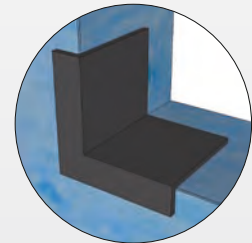

2. Flat sill (page 14)

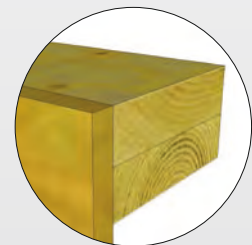

3. Sloped sill (page 22)

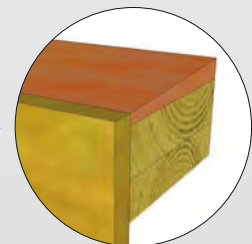

4. Backdam (page 30)

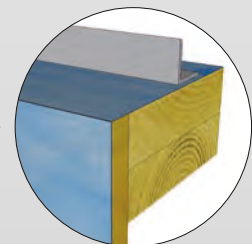

Cut-out methods for rebate windows

Cut-out method

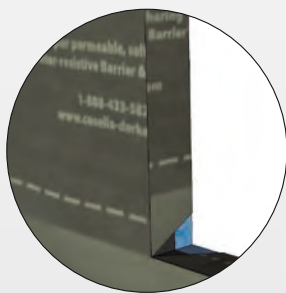

1. DELTA®-FAS CORNER (page 38)

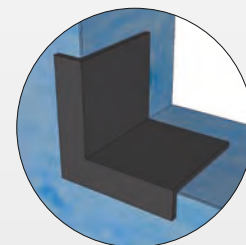

2. Flat sill (page 44)

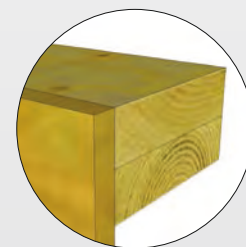

3. Sloped sill (page 50)

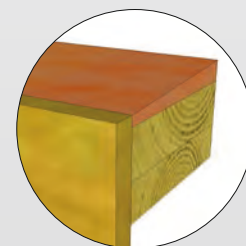

4. Backdam (page 56)

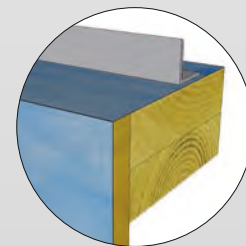

Strip-in method

1. With DELTA®-FAS CORNER

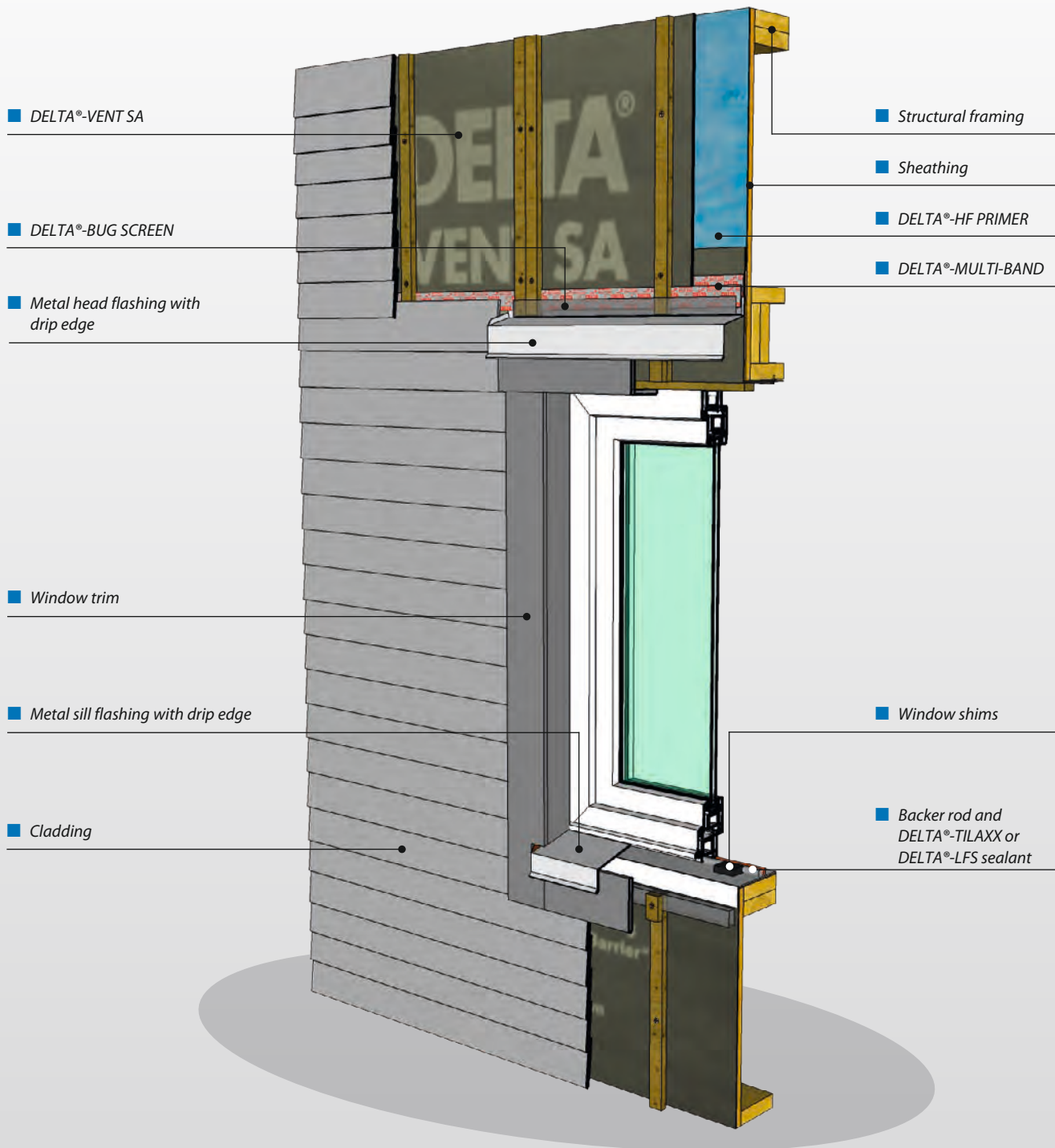

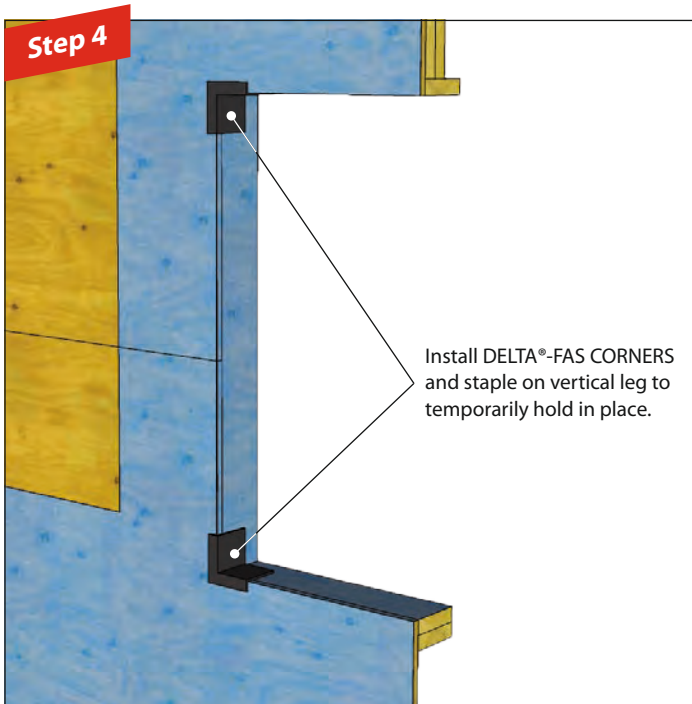

Strip-in method

1. With DELTA®-FAS CORNER

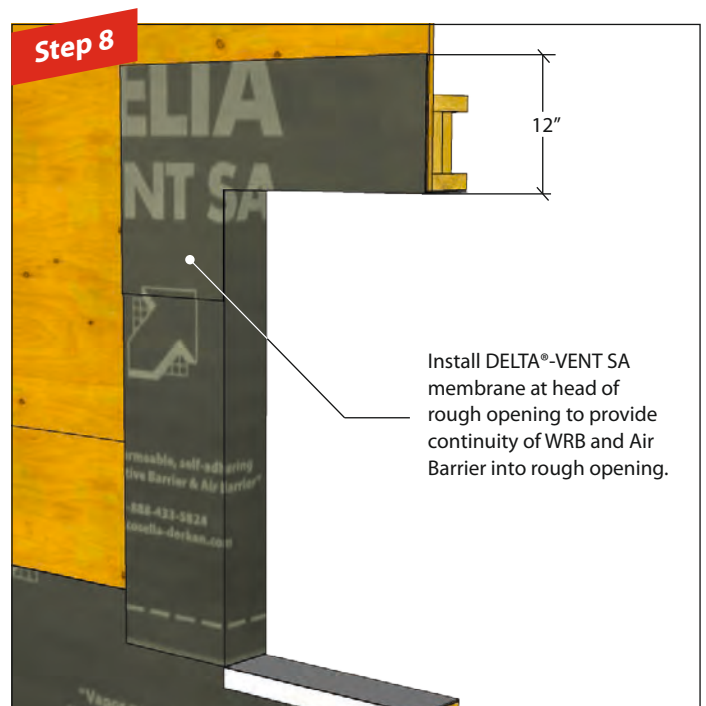
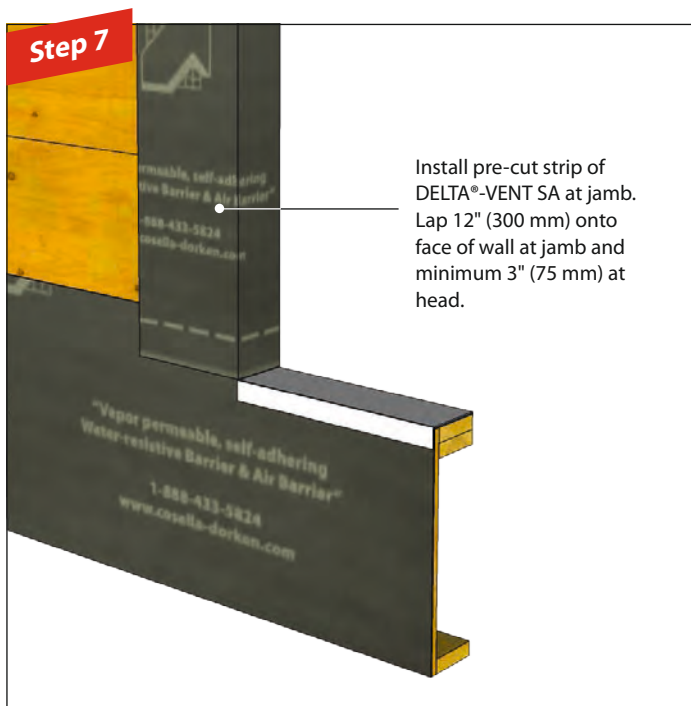
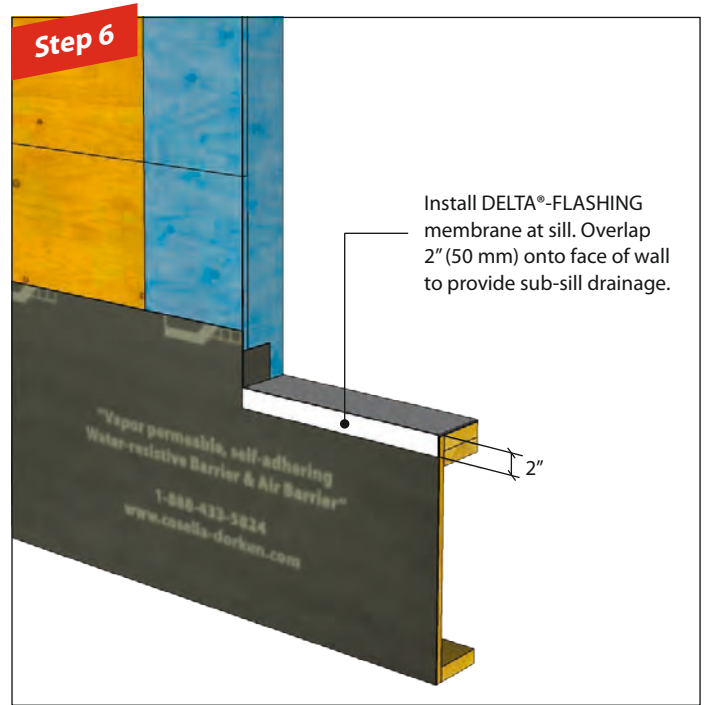

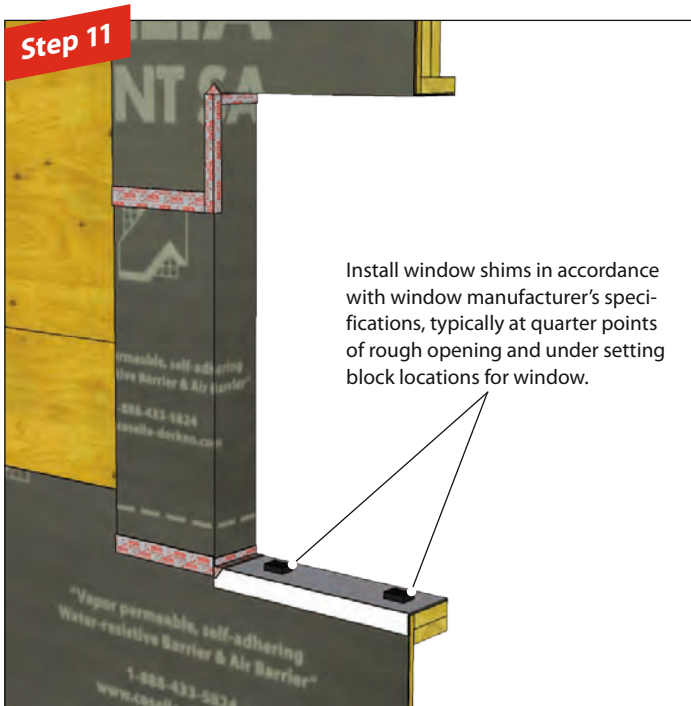
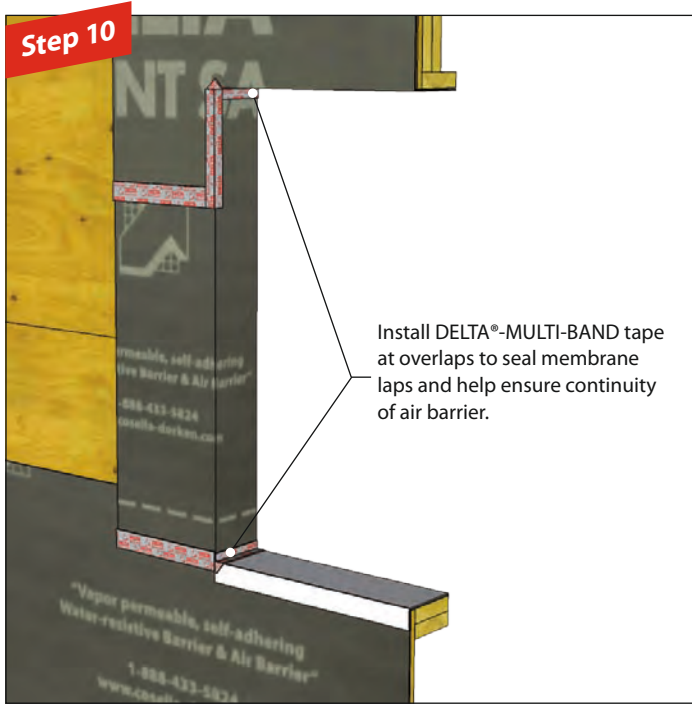
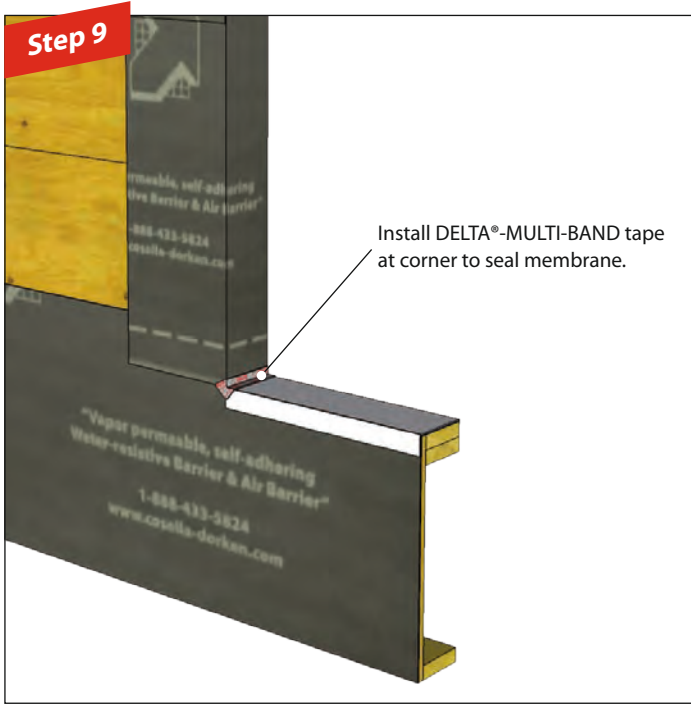

Strip-in method

1. With DELTA®-FAS CORNER

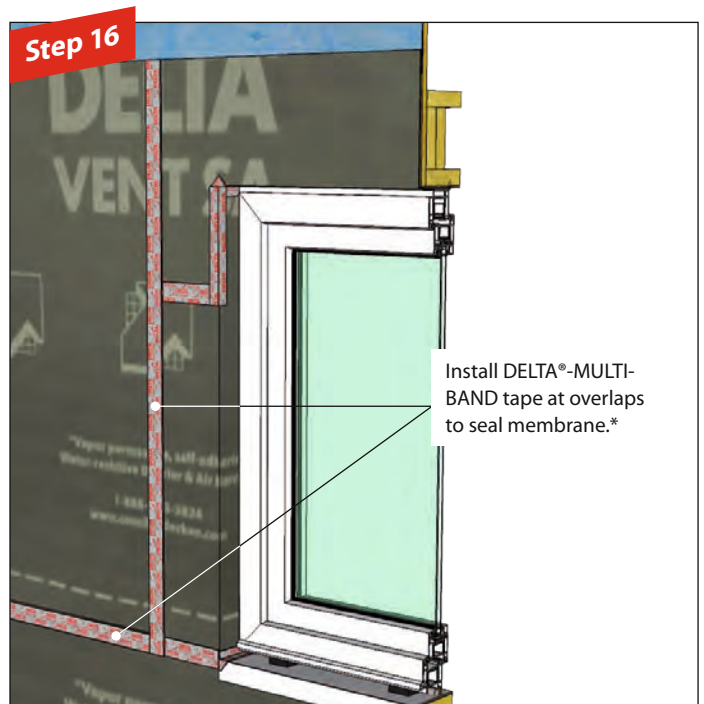
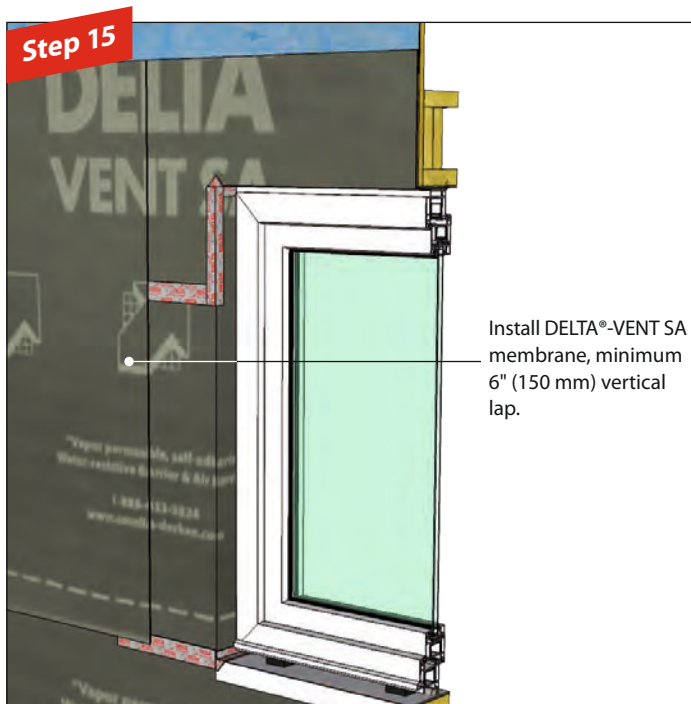
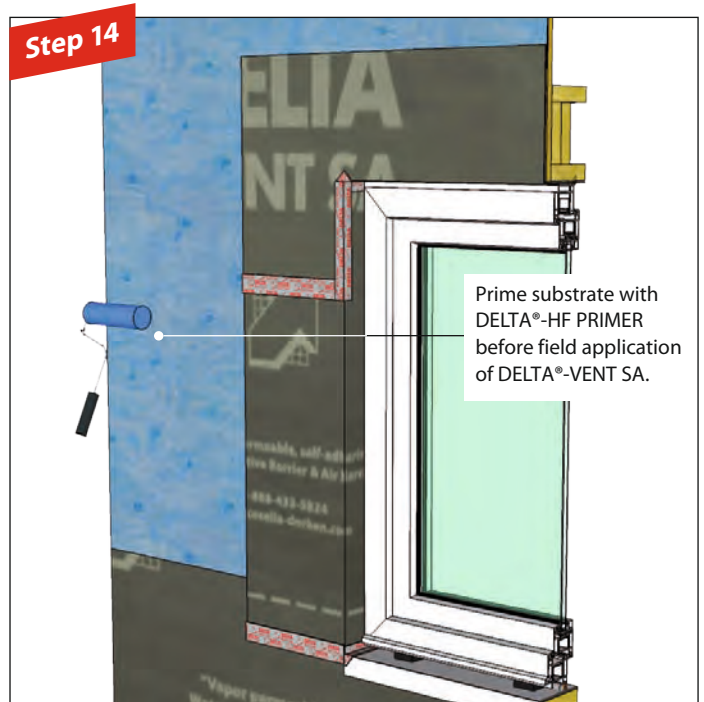

* Not required where there is a self-adhered edge.

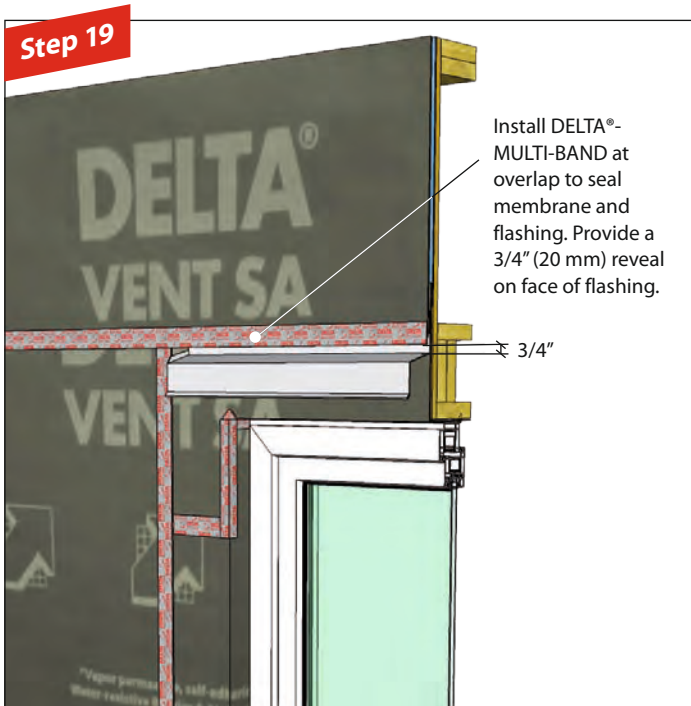
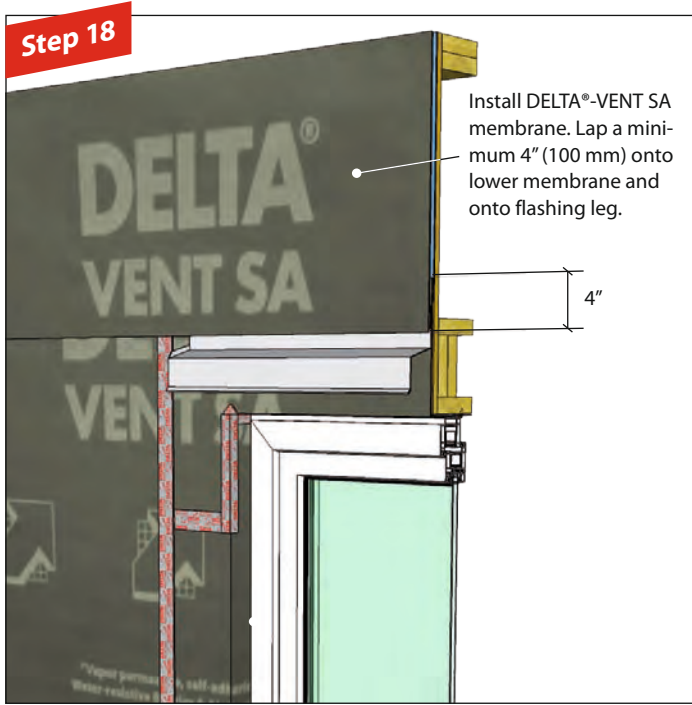

Strip-in method

1. With DELTA®-FAS CORNER

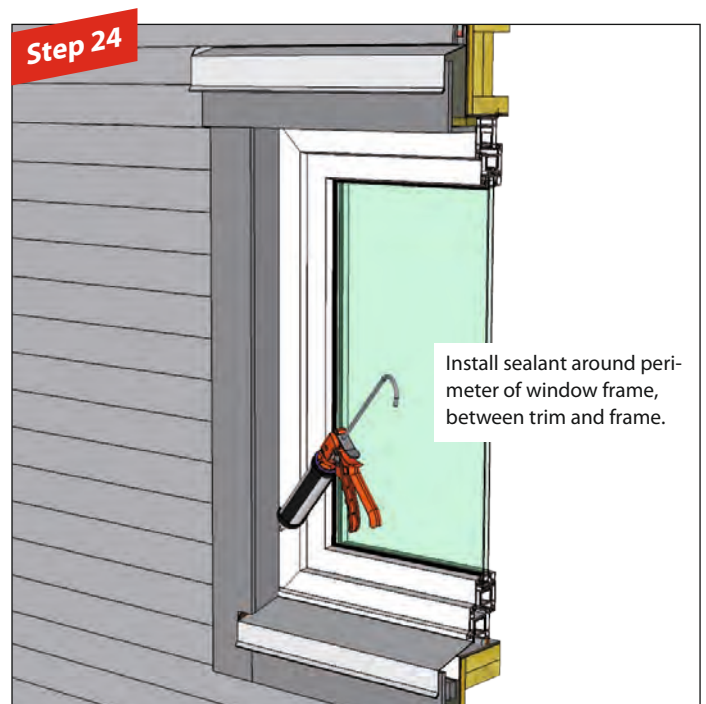
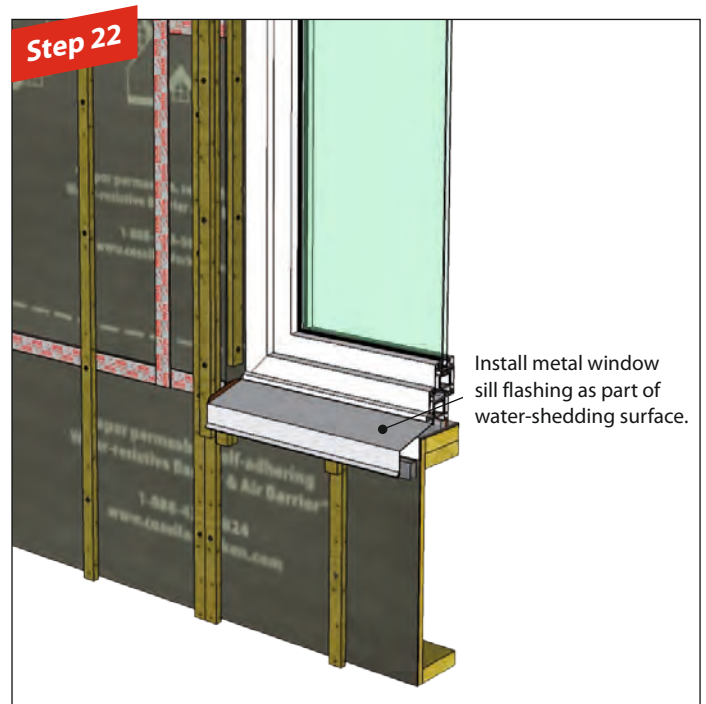

Notes

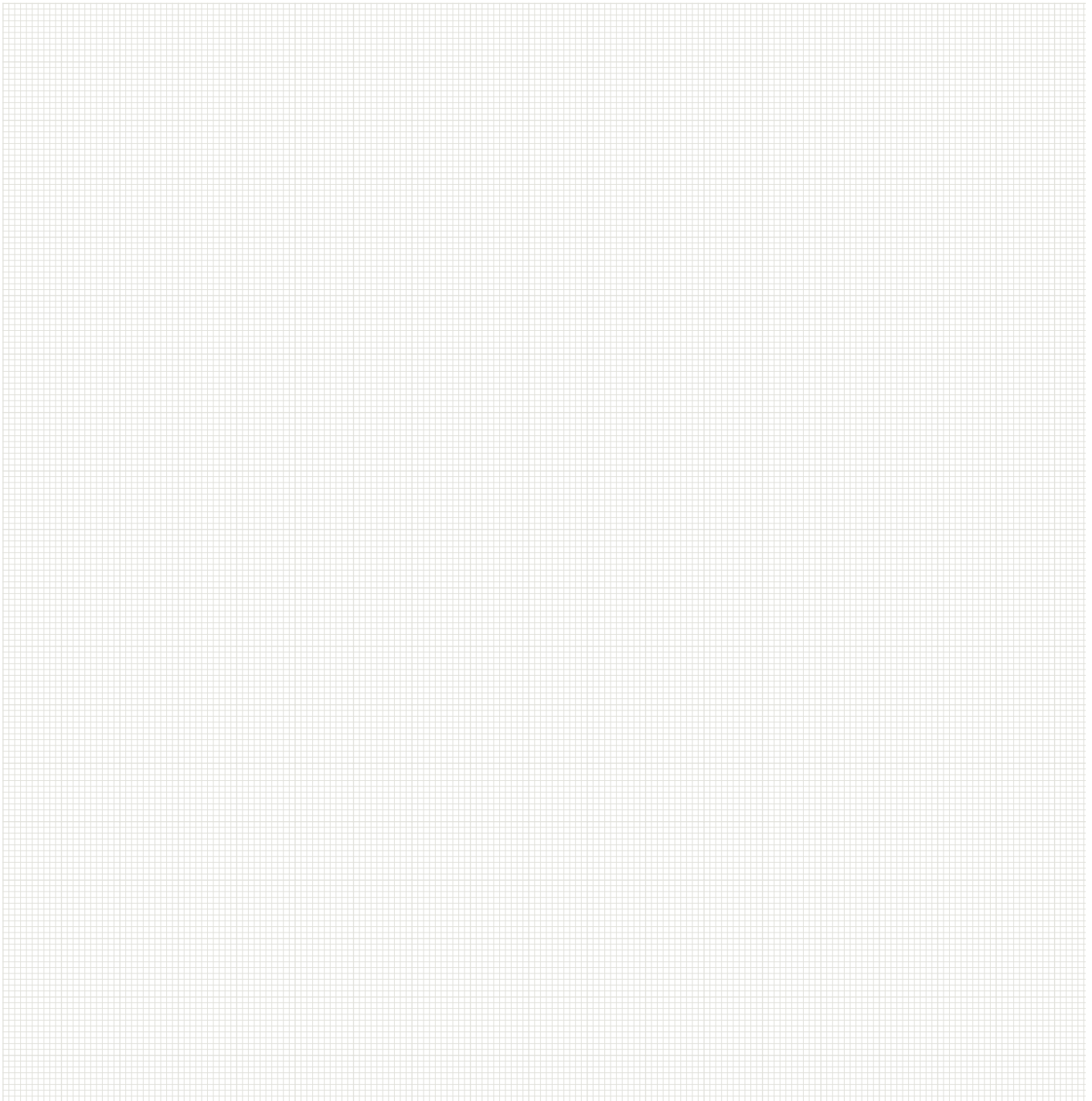

Strip-in method

2. With flat sill

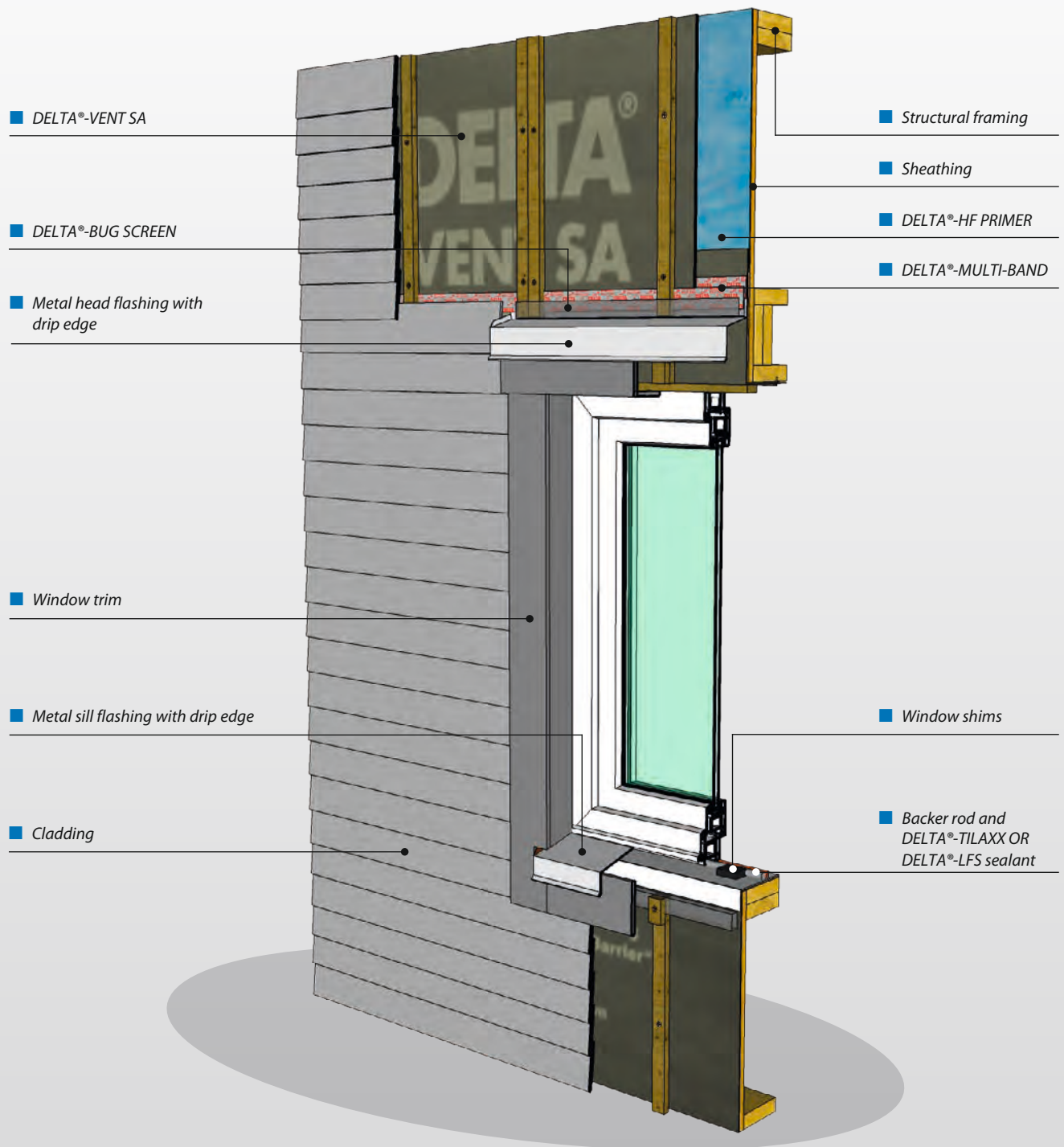



Strip-in method

2. With flat sill

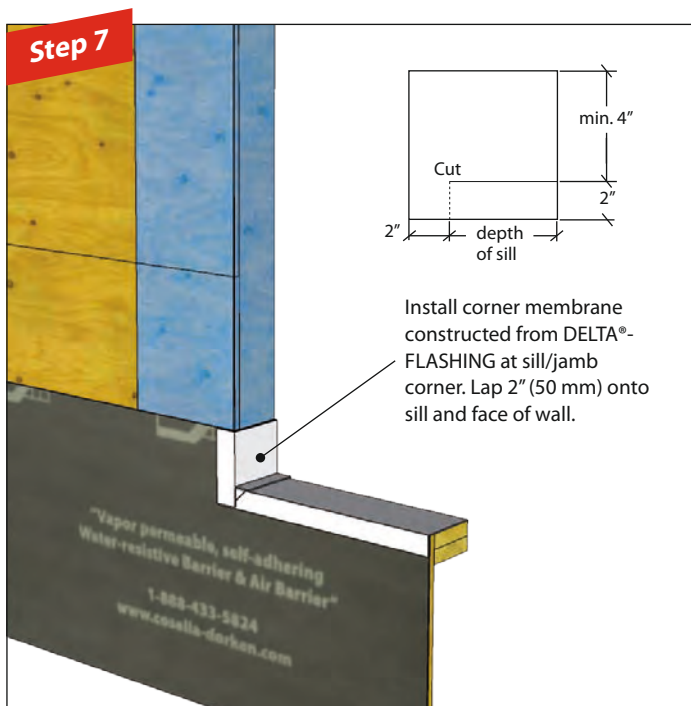
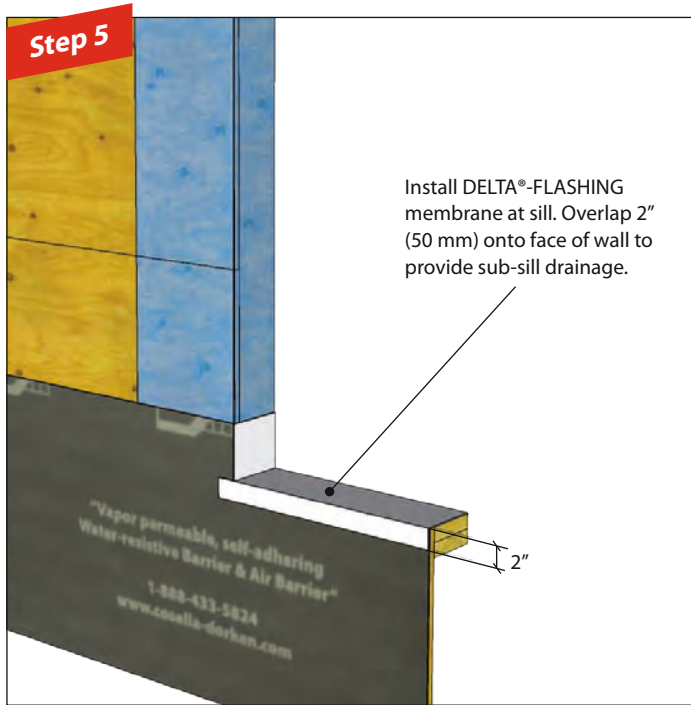

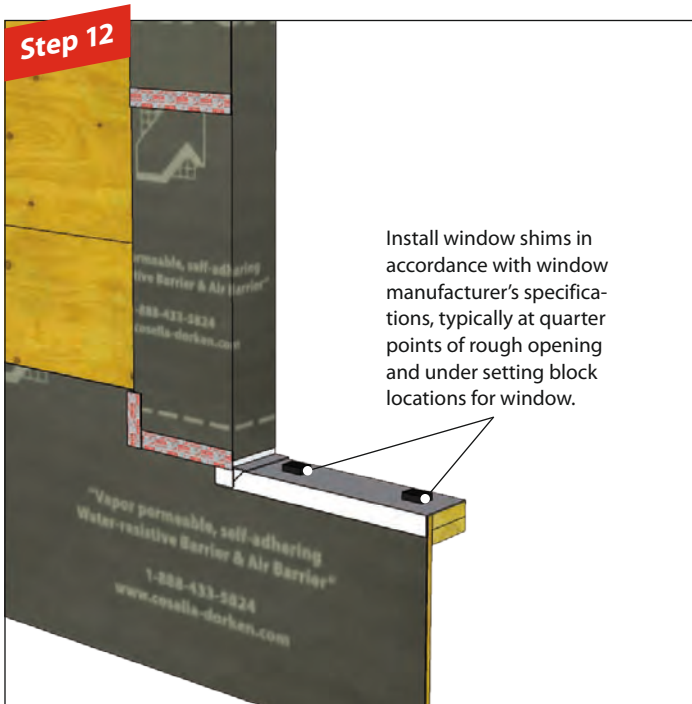
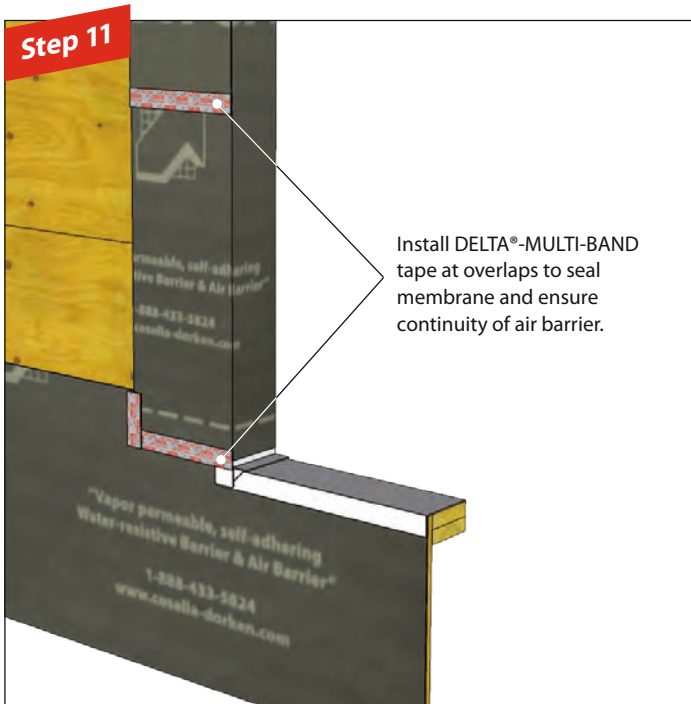

Strip-in method

2. With flat sill

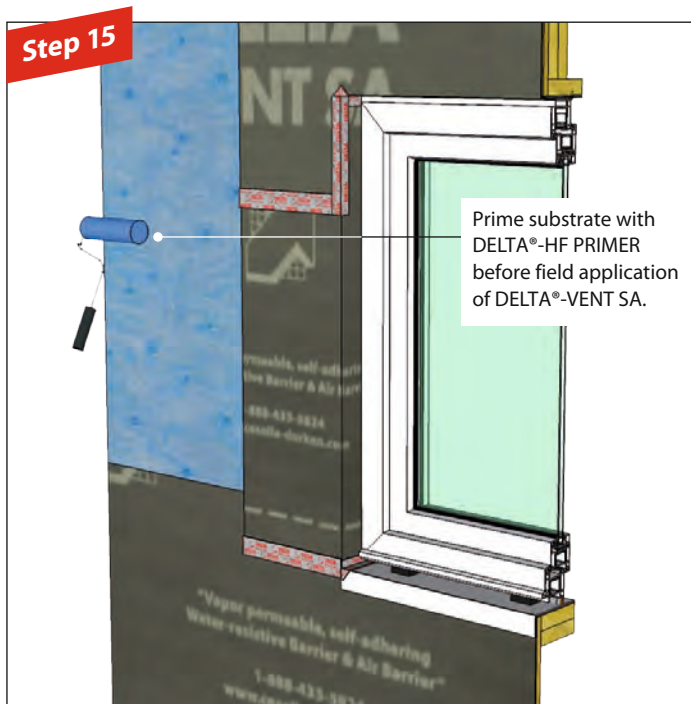
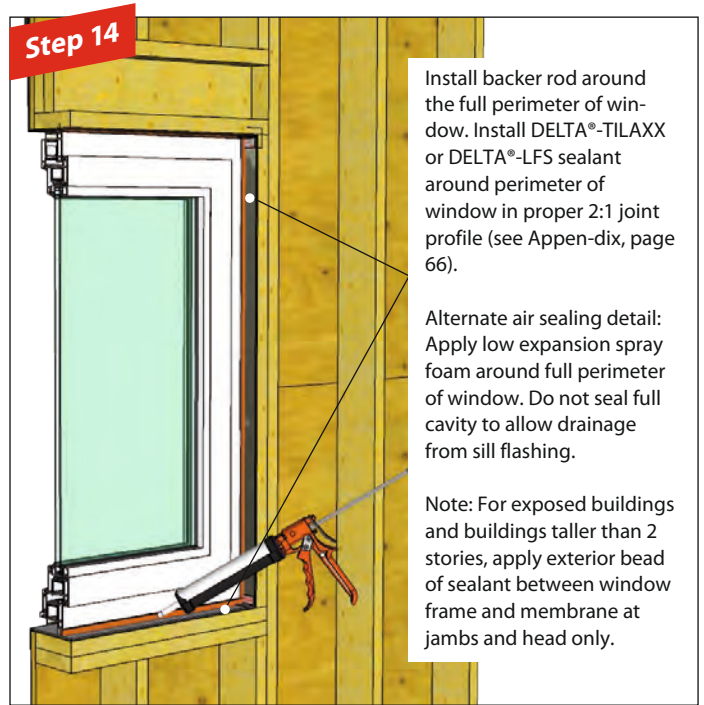

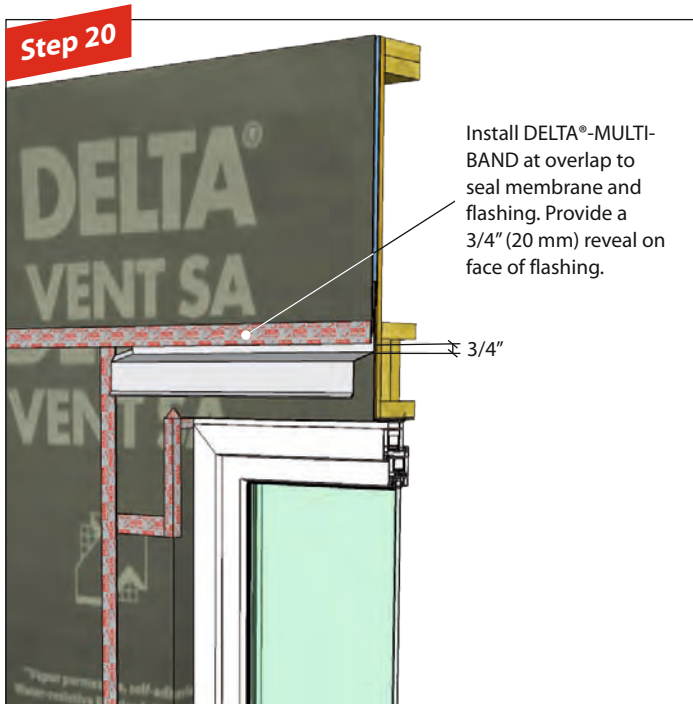
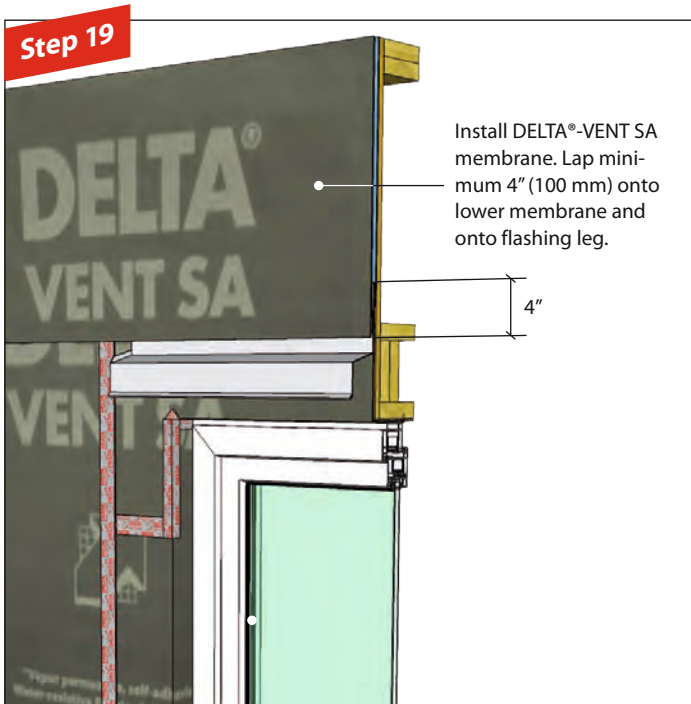
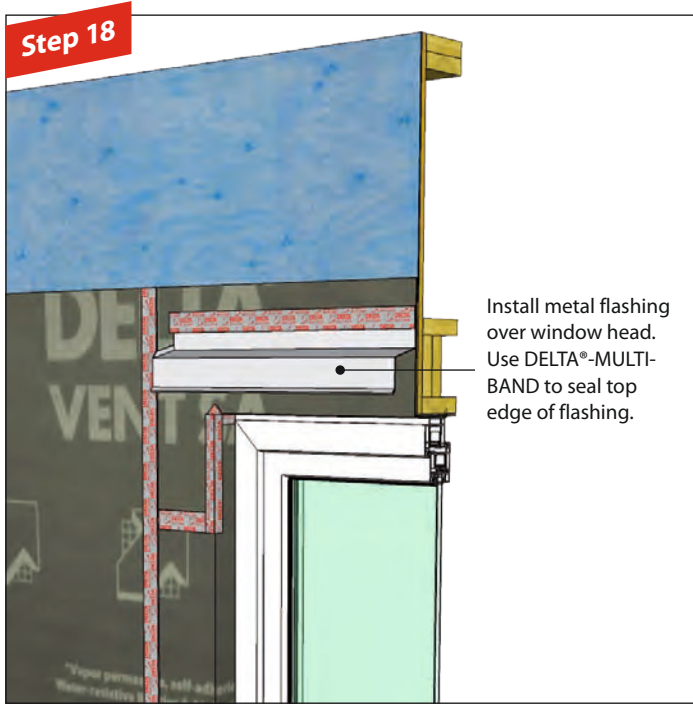
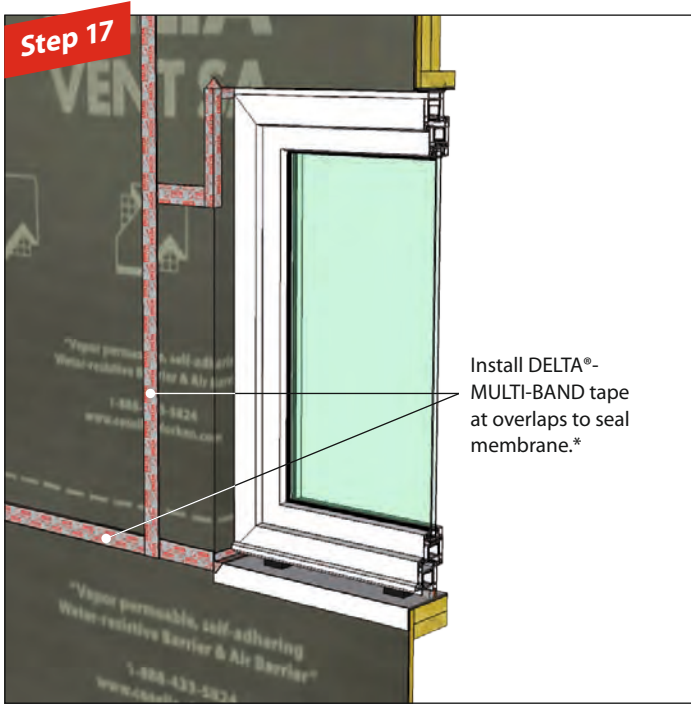

* Not required where there is a self-adhered edge.

Strip-in method

2. With flat sill

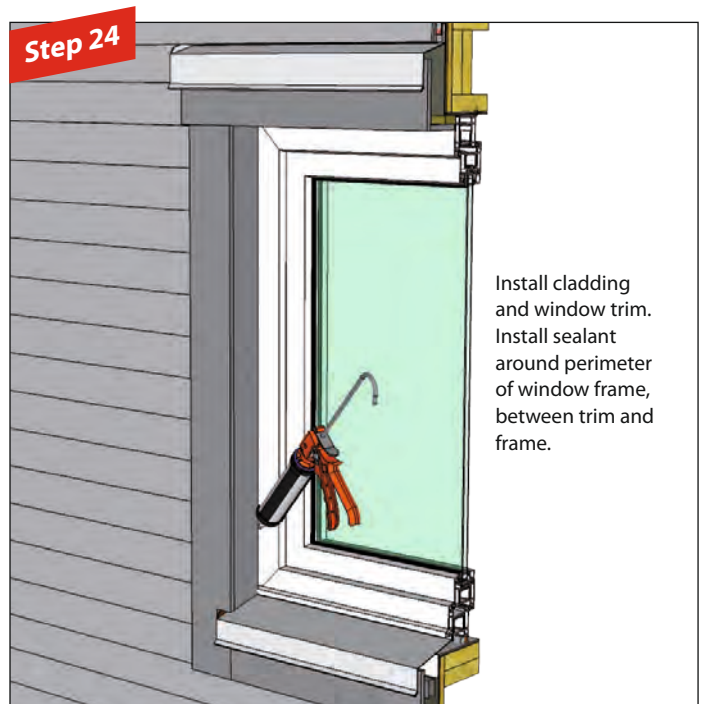
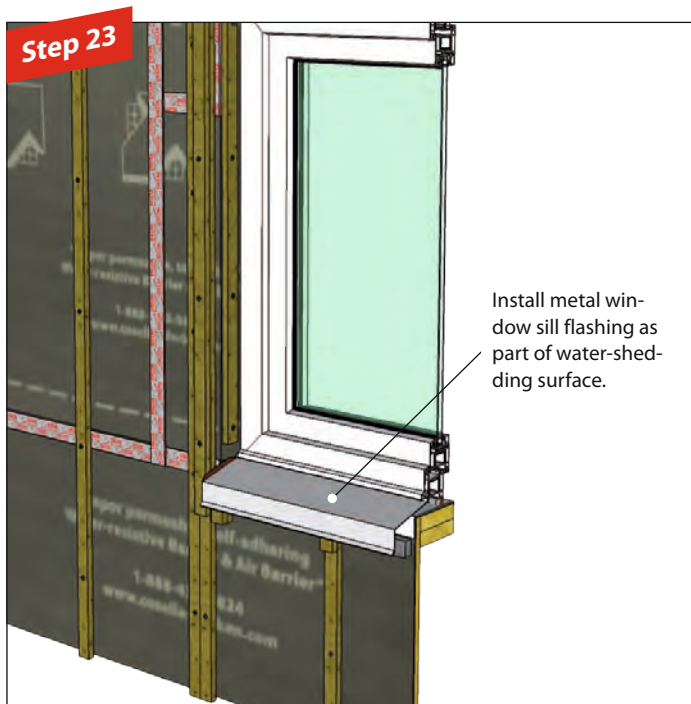

Notes

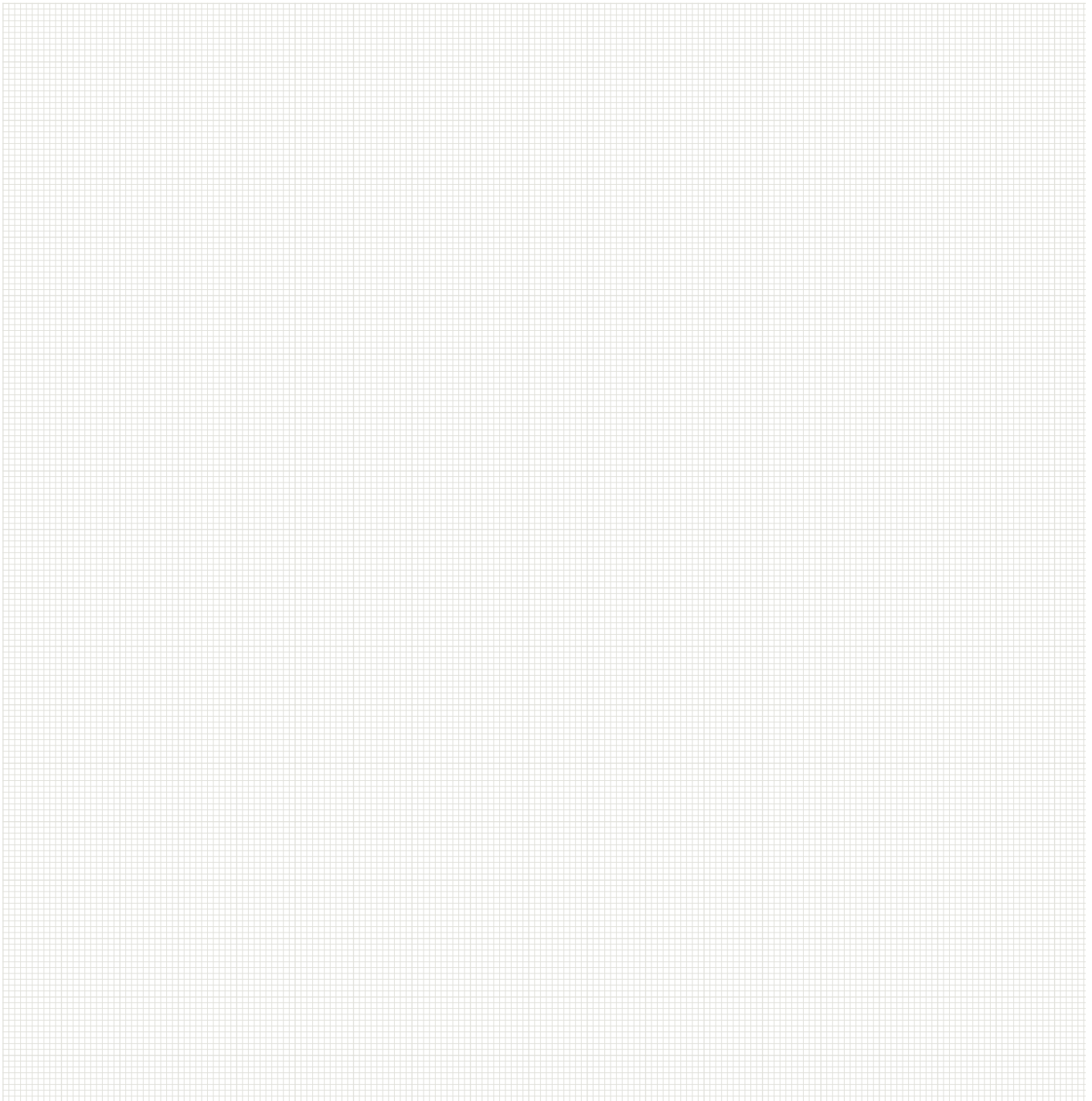

Strip-in method

3. With sloped sill

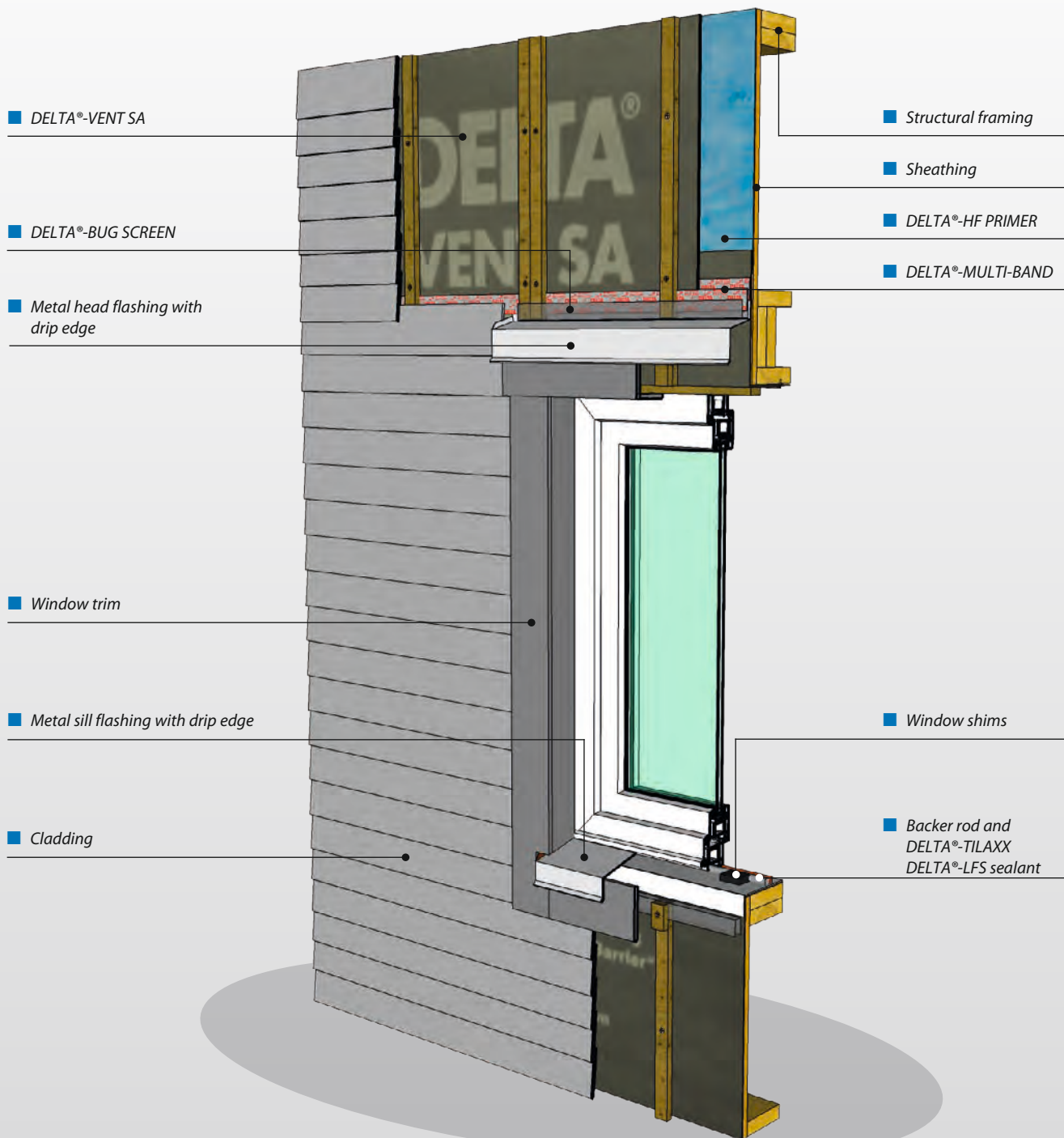



Strip-in method

3. With sloped sill

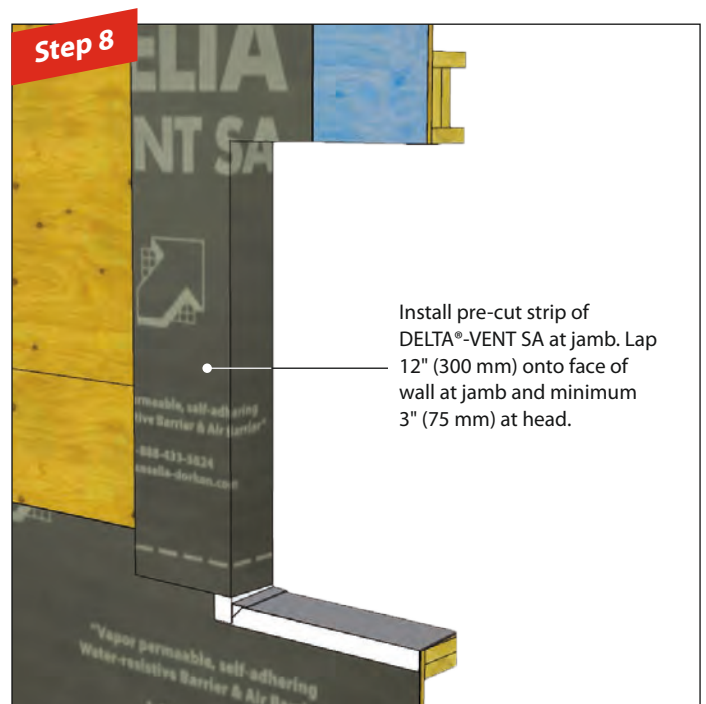
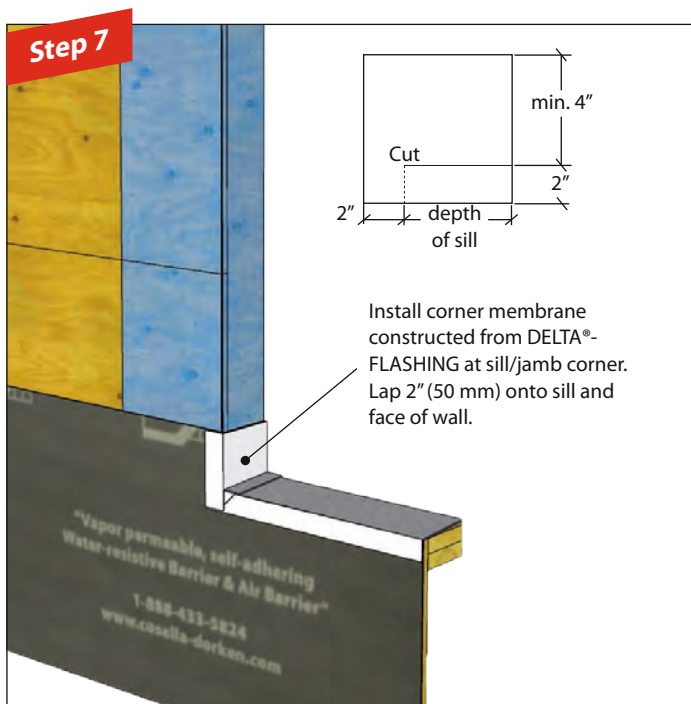
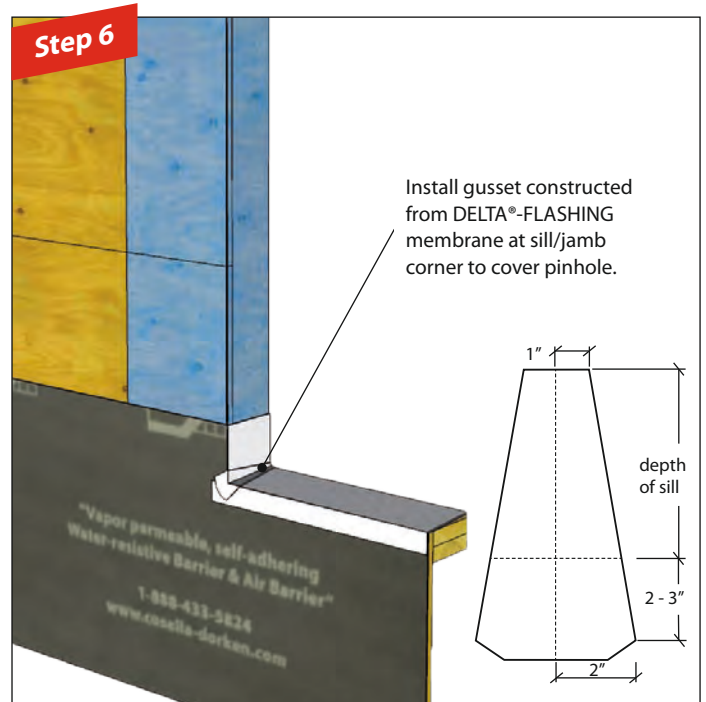
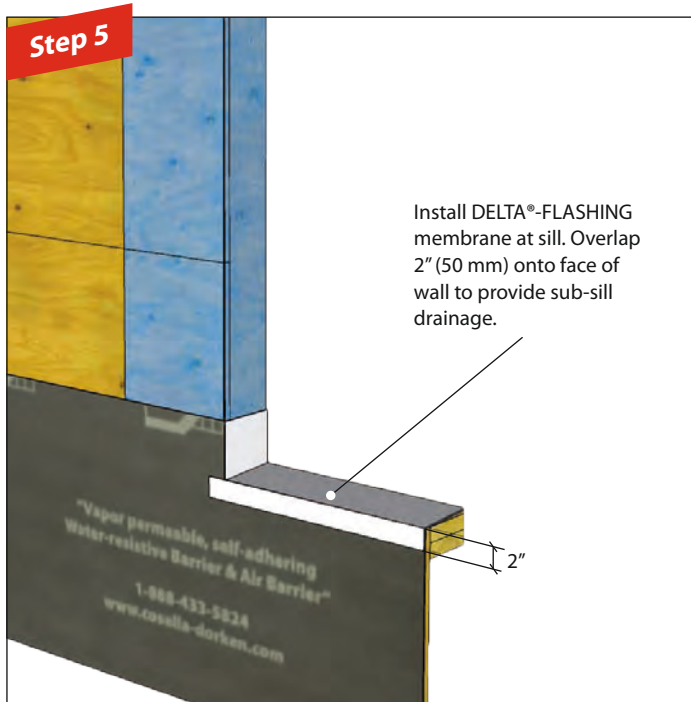

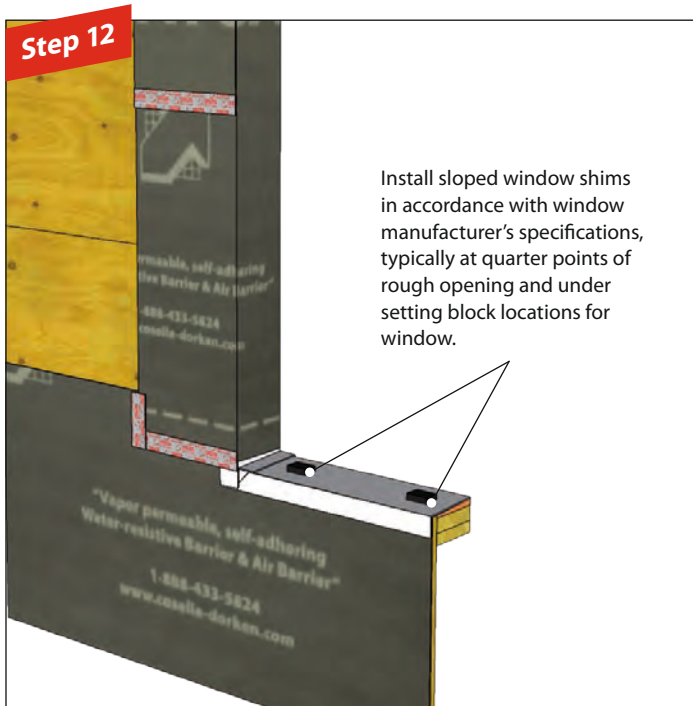
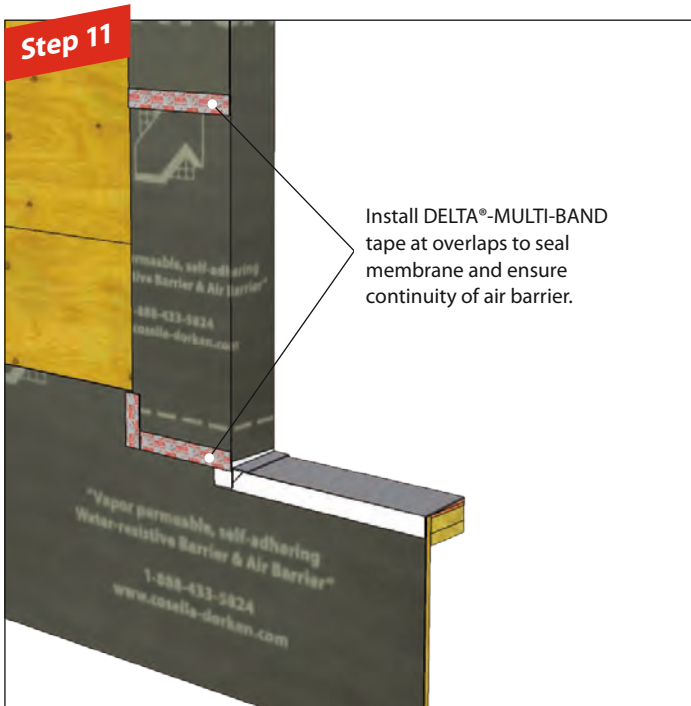
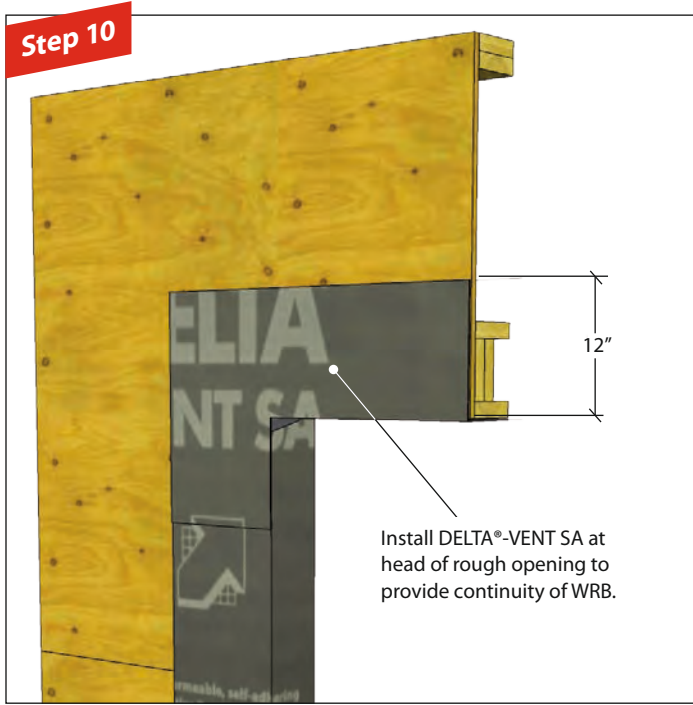

Strip-in method

3. With sloped sill

Step 13



Install window in accordance with manufacturer's specifications. Generally the gap between window and rough opening should be around 1/2" (12 mm).

The diagram shows a window unit being inserted into a rough opening in a wall. The wall is covered with a dark, textured membrane. The window is positioned such that there is a consistent gap between the frame and the opening.

Step 14



Install backer rod around the full perimeter of window. Install DELTA®-TILAXX or DELTA®-LFS sealant around perimeter of window in proper 2:1 joint profile (see Appendix, page 66).

Alternate air sealing detail: Apply low expansion spray foam around full perimeter of window. Do not seal full cavity to allow drainage from sill flashing.

Note: For exposed buildings and buildings taller than 2 stories, apply exterior bead of sealant between window frame and membrane at jambs and head only.

The diagram shows the window unit from Step 13 now fully installed. A backer rod is visible around the perimeter of the window. A spray gun is shown applying sealant into the joint between the window frame and the wall membrane.

Step 15



Prime substrate with DELTA®-HF PRIMER before field application of DELTA®-VENT SA.

The diagram shows the window unit with a blue primer being applied to the substrate on the left side of the window. The primer is being applied in a vertical strip.

Step 16

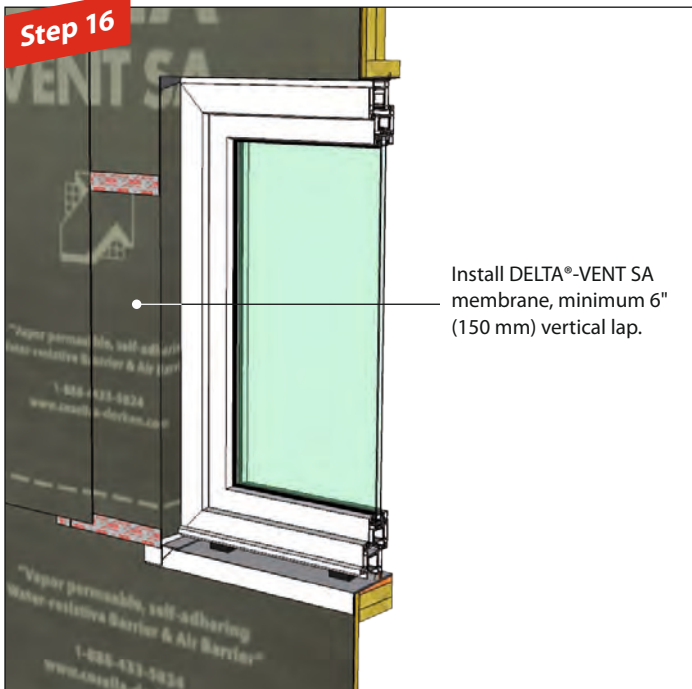

Install DELTA®-VENT SA membrane, minimum 6" (150 mm) vertical lap.

The diagram shows the window unit with the DELTA-VENT SA membrane being applied to the substrate. The membrane is being applied in a vertical strip, overlapping the primer from the previous step.

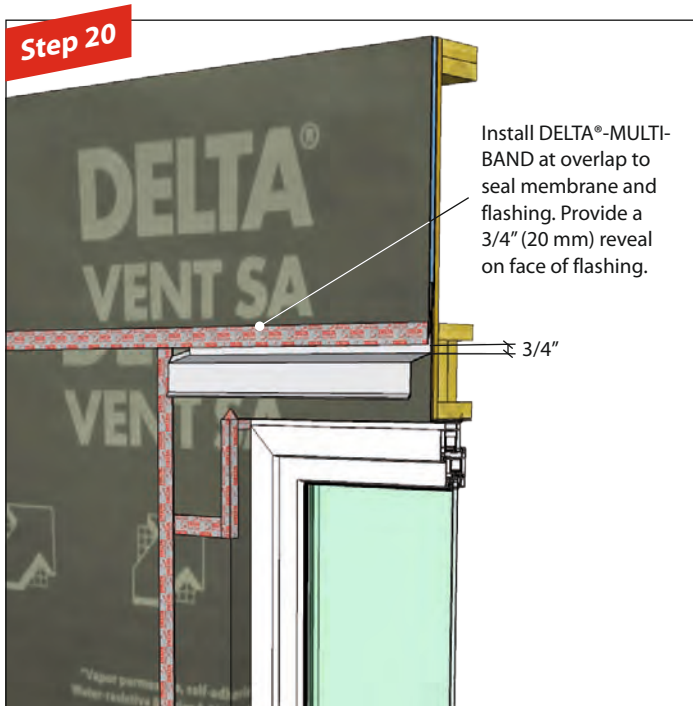
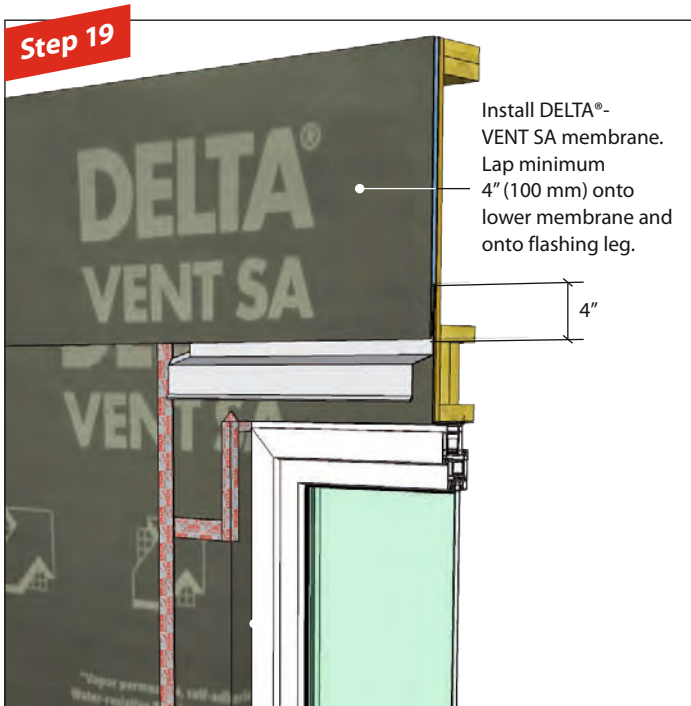
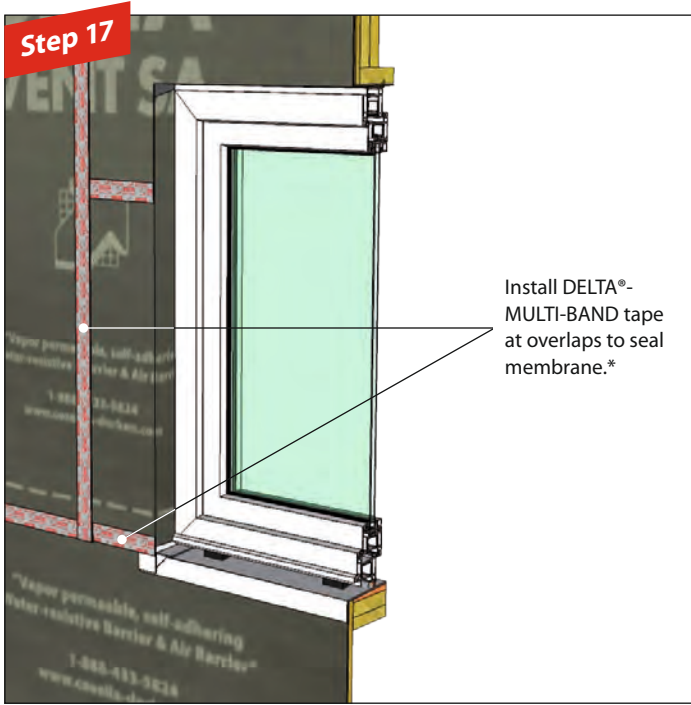

* Not required where there is a self-adhered edge.

Strip-in method

3. With sloped sill

Step 21



Install vertical strap-
ping for cladding
attachment and to
provide cavity for
drainage and venting.

Step 22

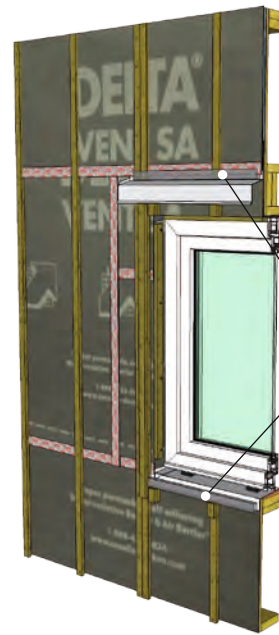

Install DELTA®-
BUG SCREEN
at cladding open-
ings. Fasten in
place with nails.

Step 23

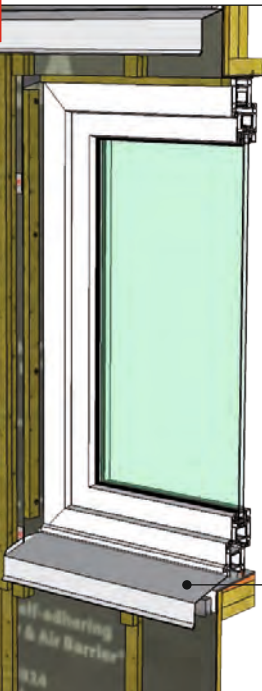

Install metal
window sill flashing
as part of water-
shedding surface.

Step 24

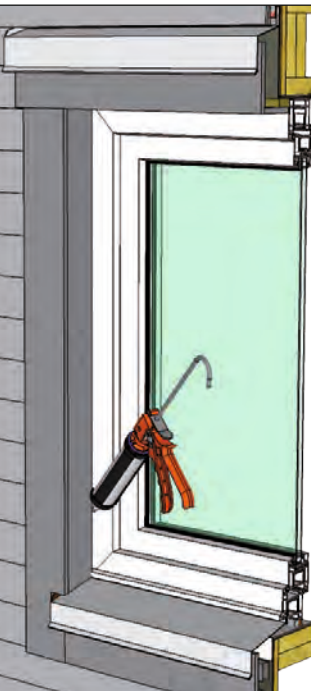

Install cladding
and window trim.
Install sealant
around perimeter
of window frame,
between trim and
frame.

Notes

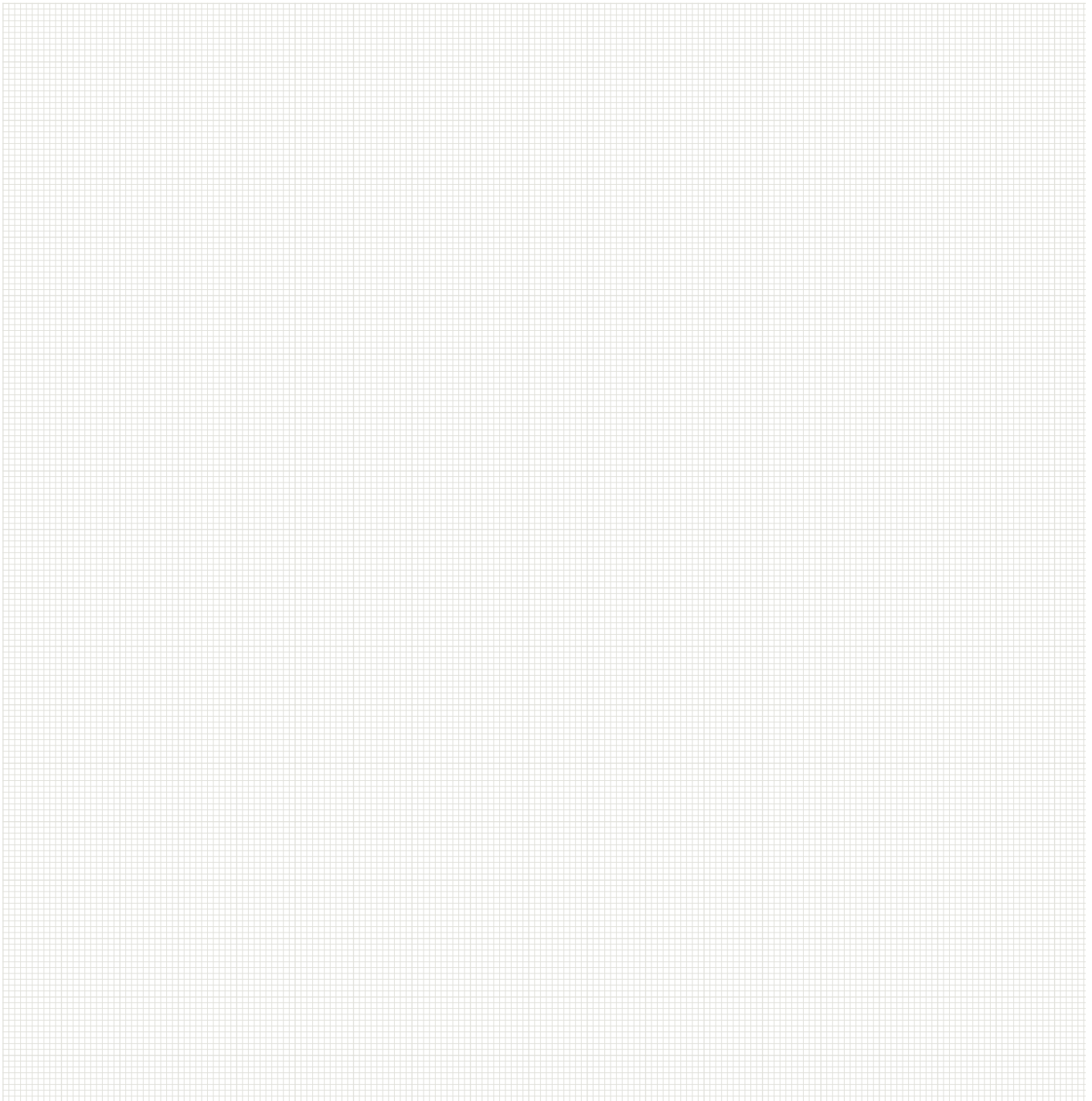

Strip-in method

4. With backdam

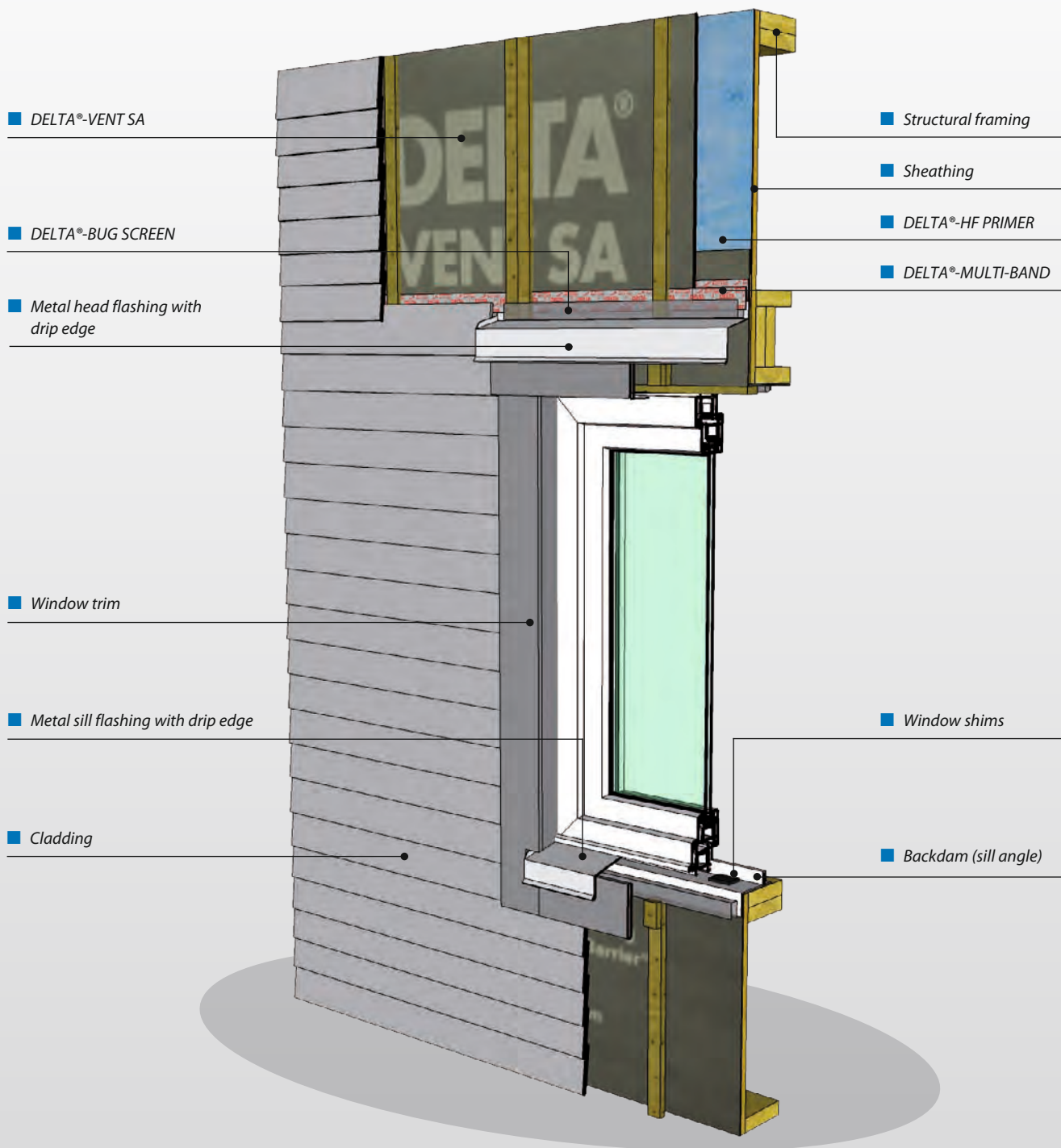



Strip-in method

4. With backdam

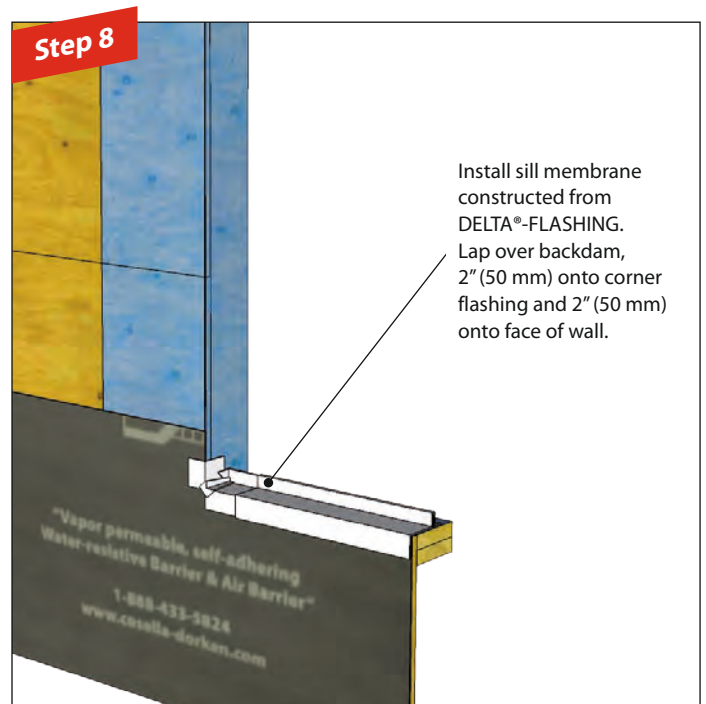
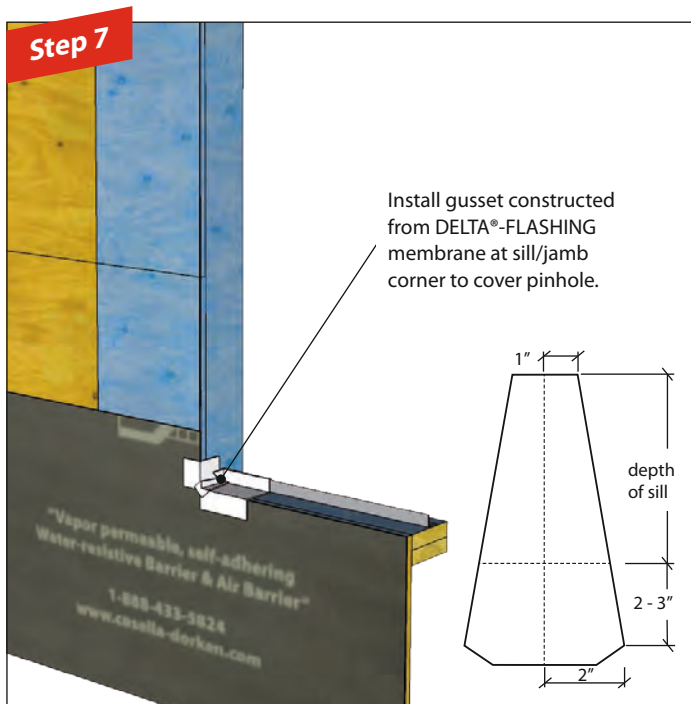
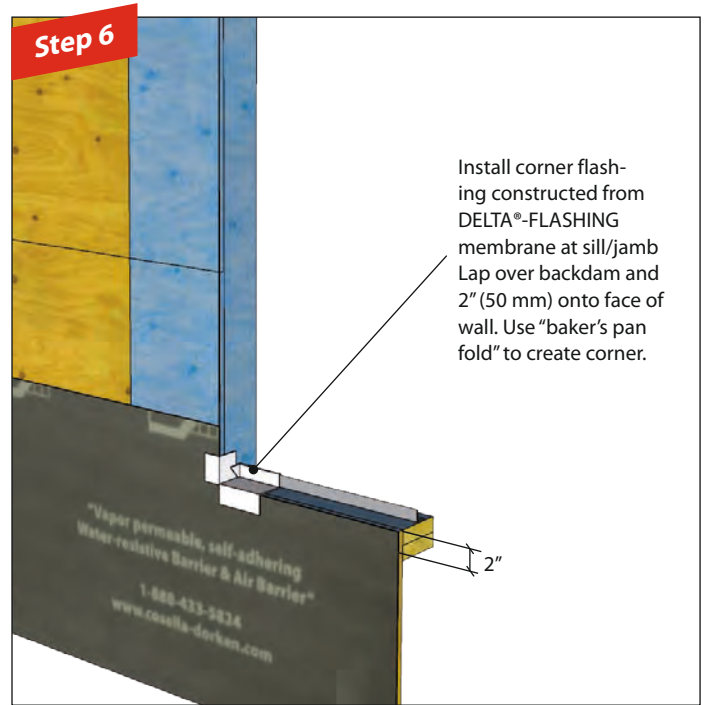
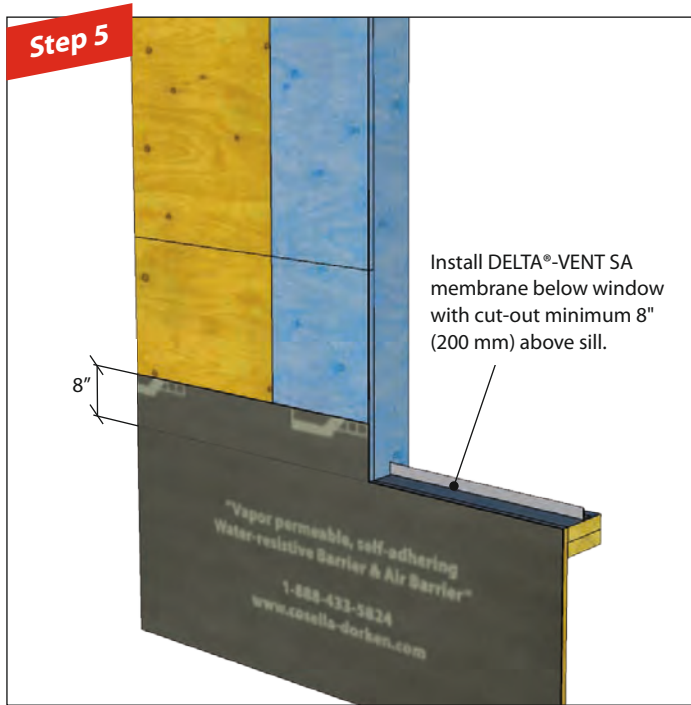

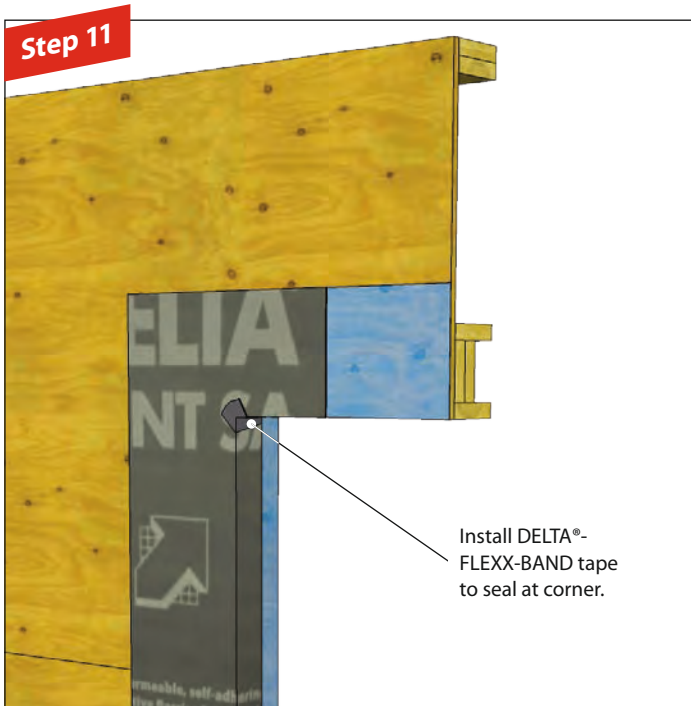
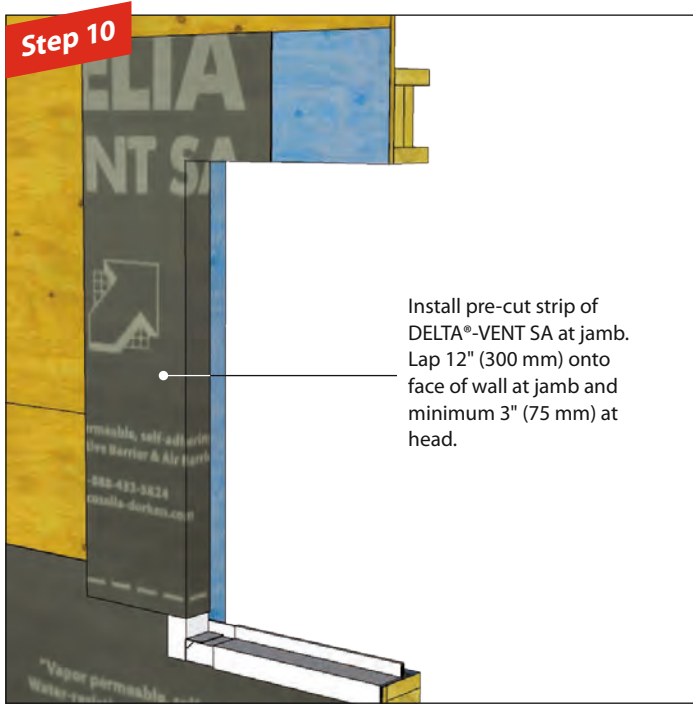
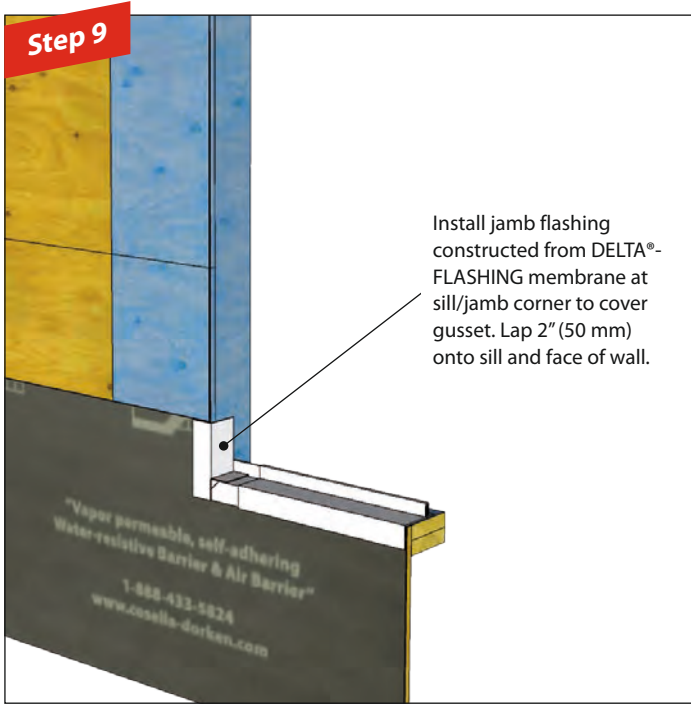

Strip-in method

4. With backdam

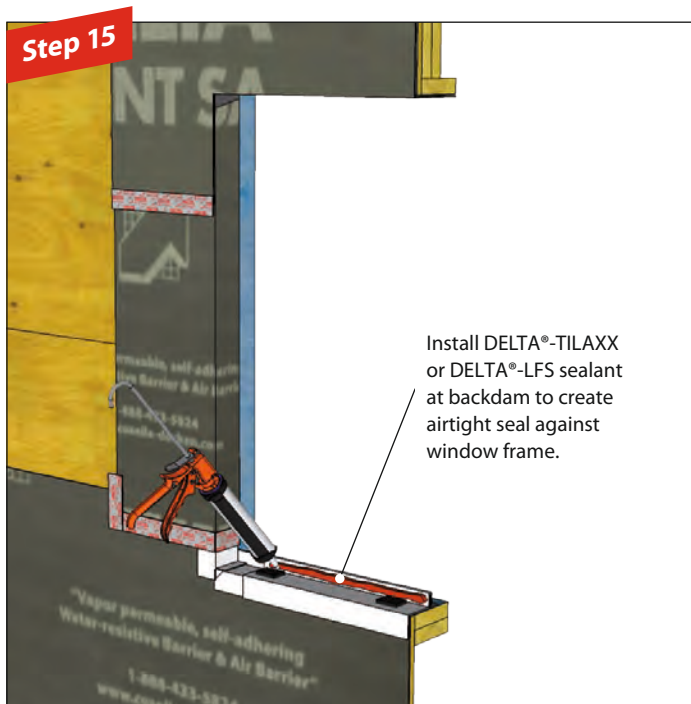
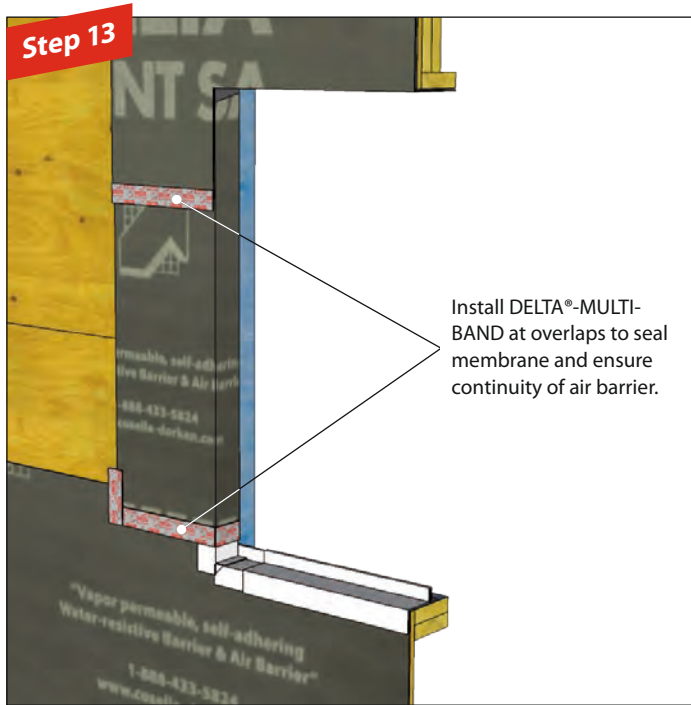

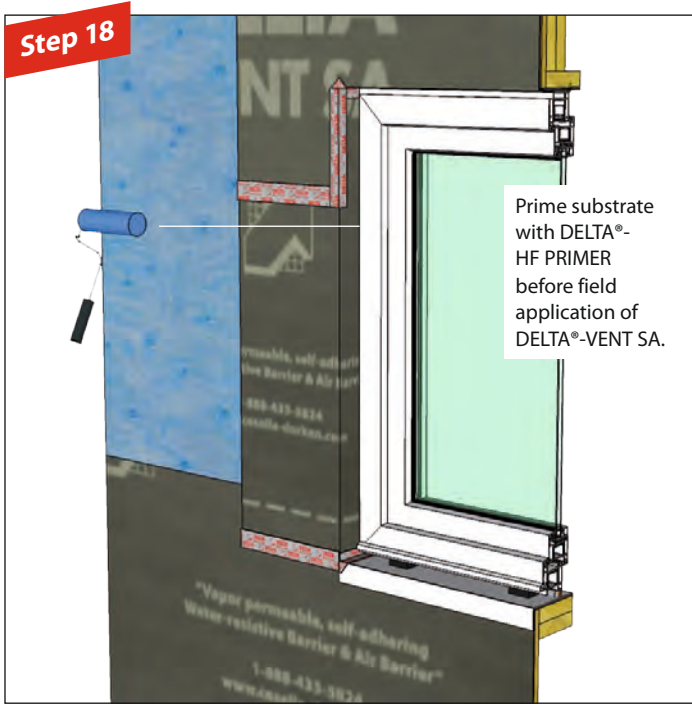

* Not required where there is a self-adhered edge.

Strip-in method

4. With backdam

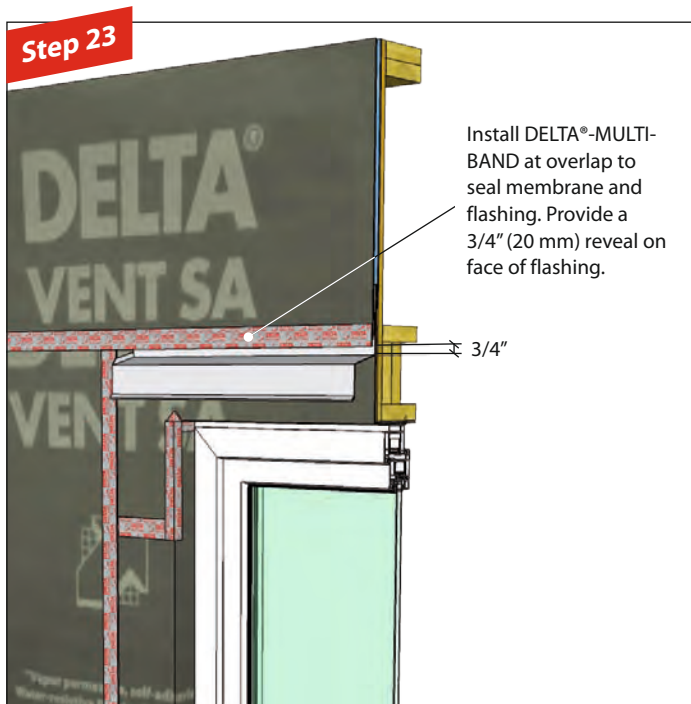
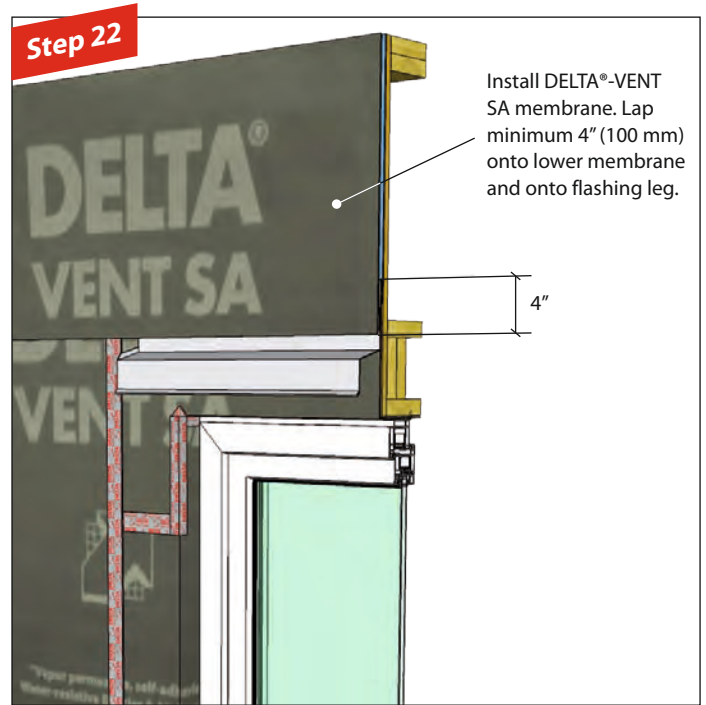

Step 25

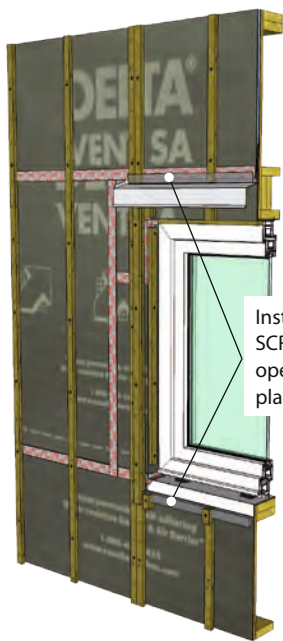

Install DELTA®-BUG SCREEN at cladding openings. Fasten in place with nails.

Step 26

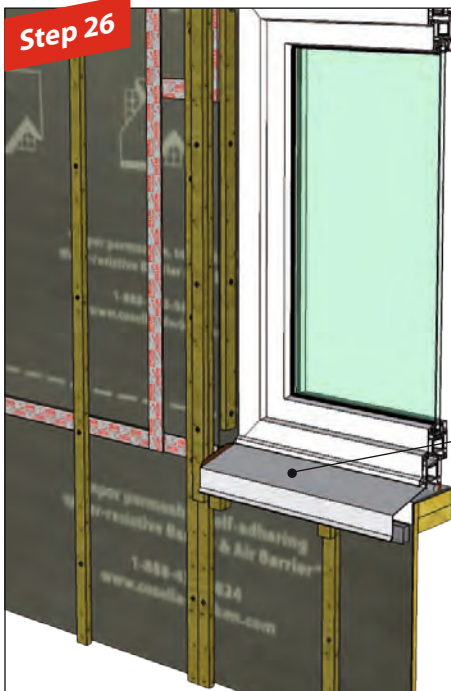

Install metal window sill flashing as part of water-shedding surface.

Step 27



Install cladding and window trim. Install sealant around perimeter of window frame, between trim and frame.

Cut-out method

5. With DELTA®-FAS CORNER

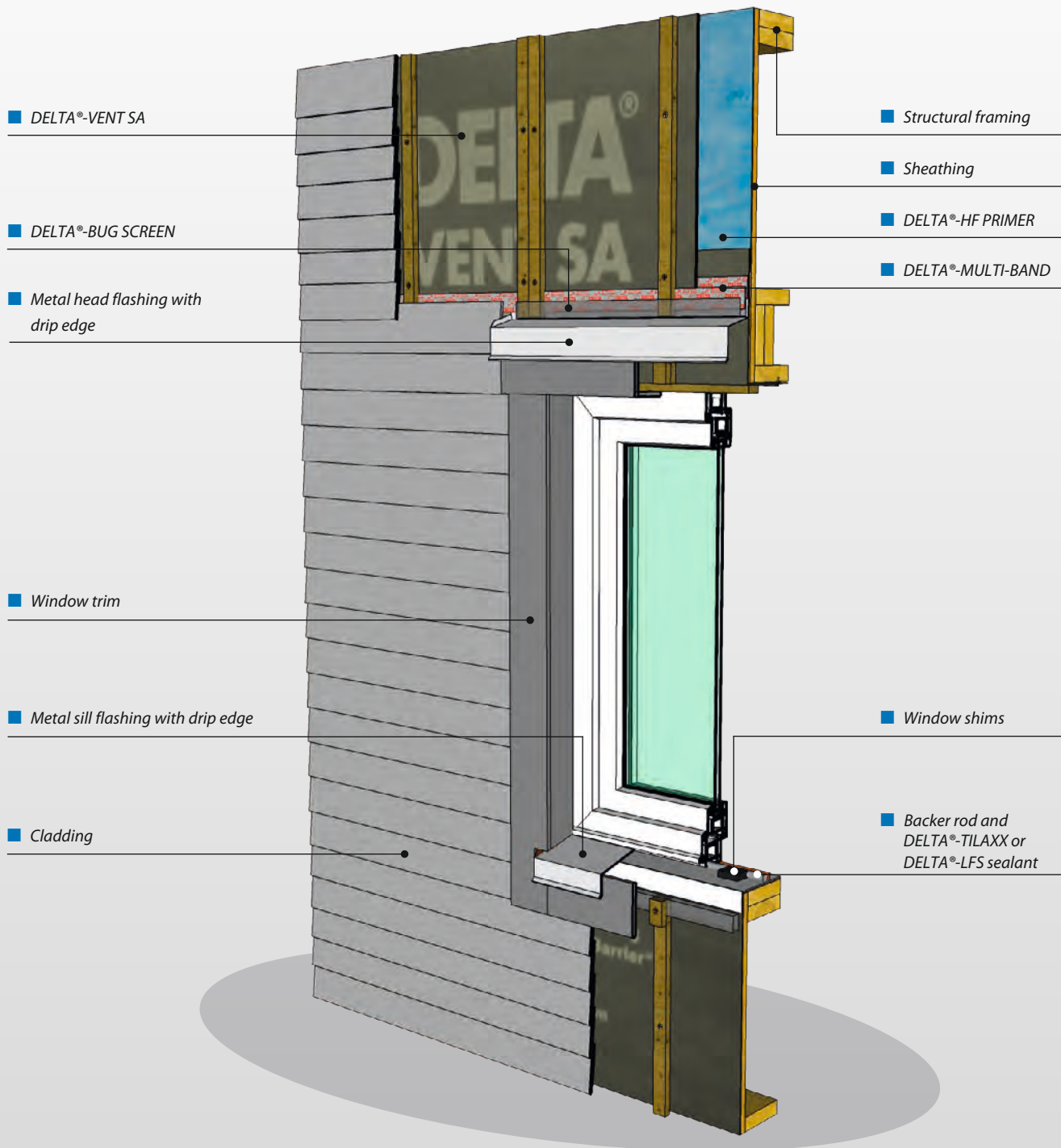

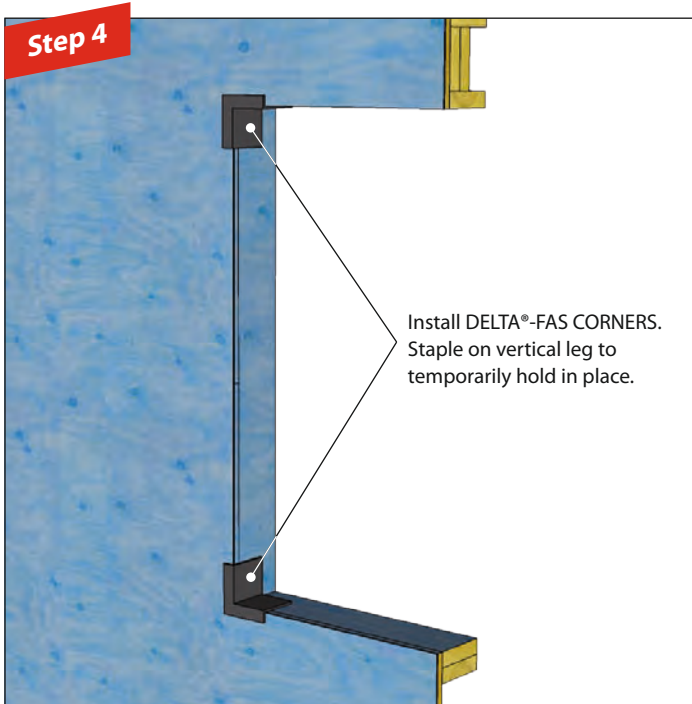

Cut-out method

5. With DELTA®-FAS CORNER

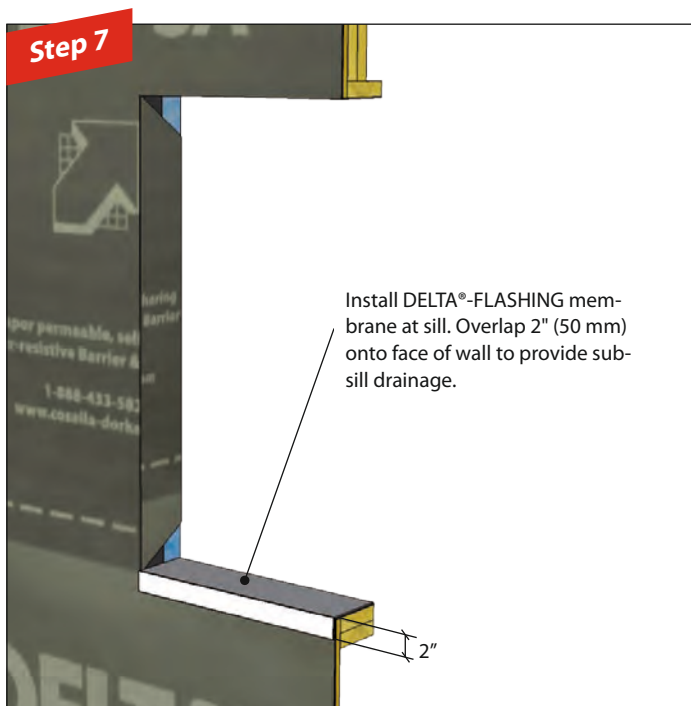
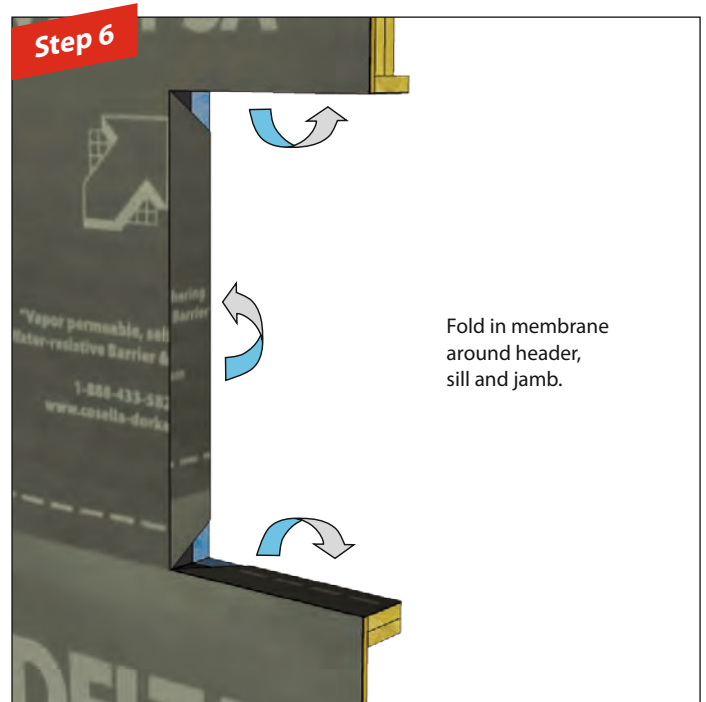

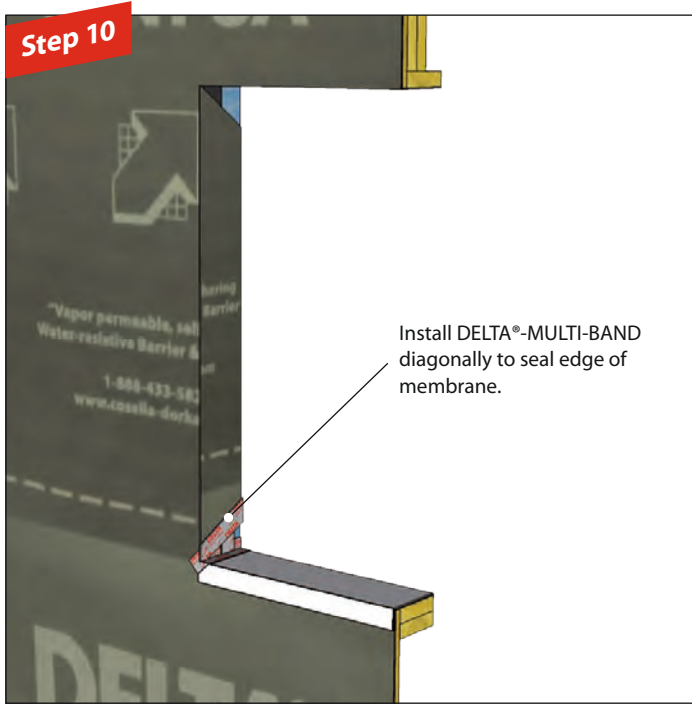

Cut-out method

5. With DELTA®-FAS CORNER

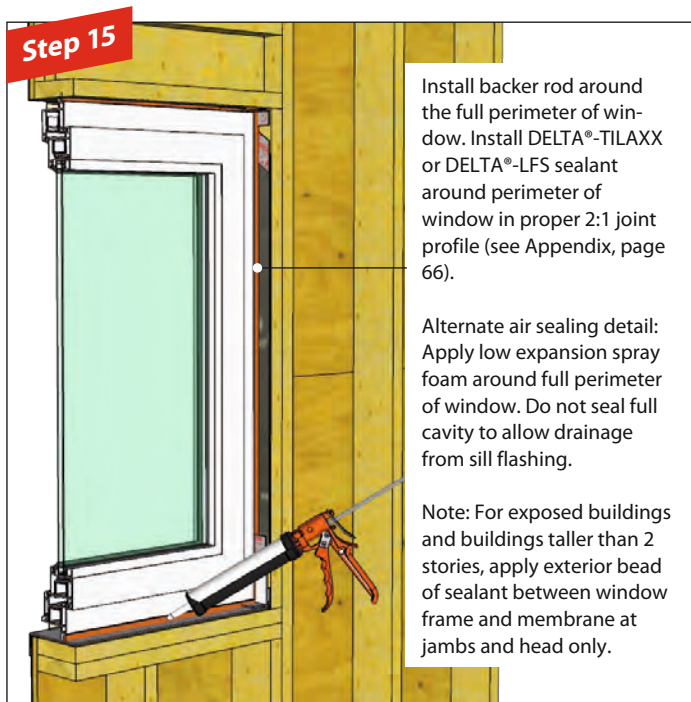

Step 17

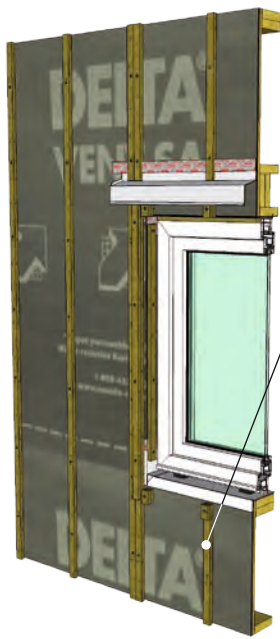

Install vertical strap-
ping for cladding
attachment and to
provide cavity for
drainage and venting.

Step 18

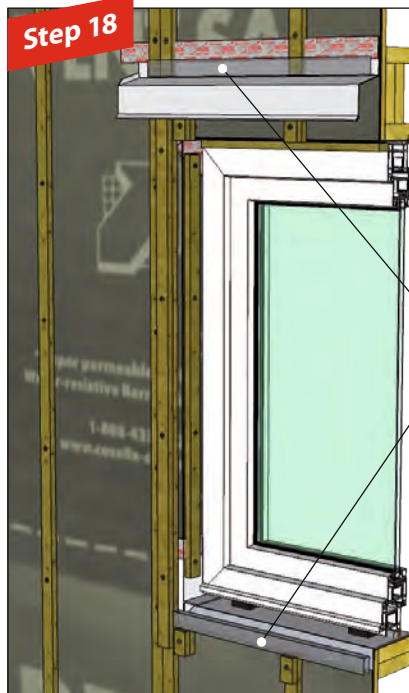

Install DELTA®-BUG
SCREEN at cladding
openings. Fasten in
place with nails.

Step 19

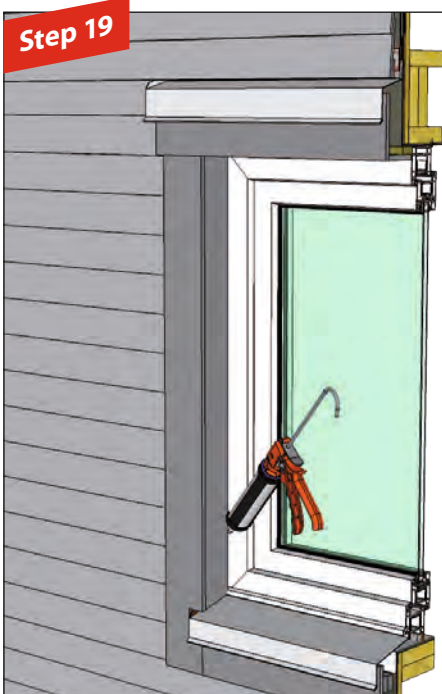

Install cladding
and window trim.
Install sealant around
perimeter of window
frame, between trim
and frame.

Cut-out method

6. With flat sill

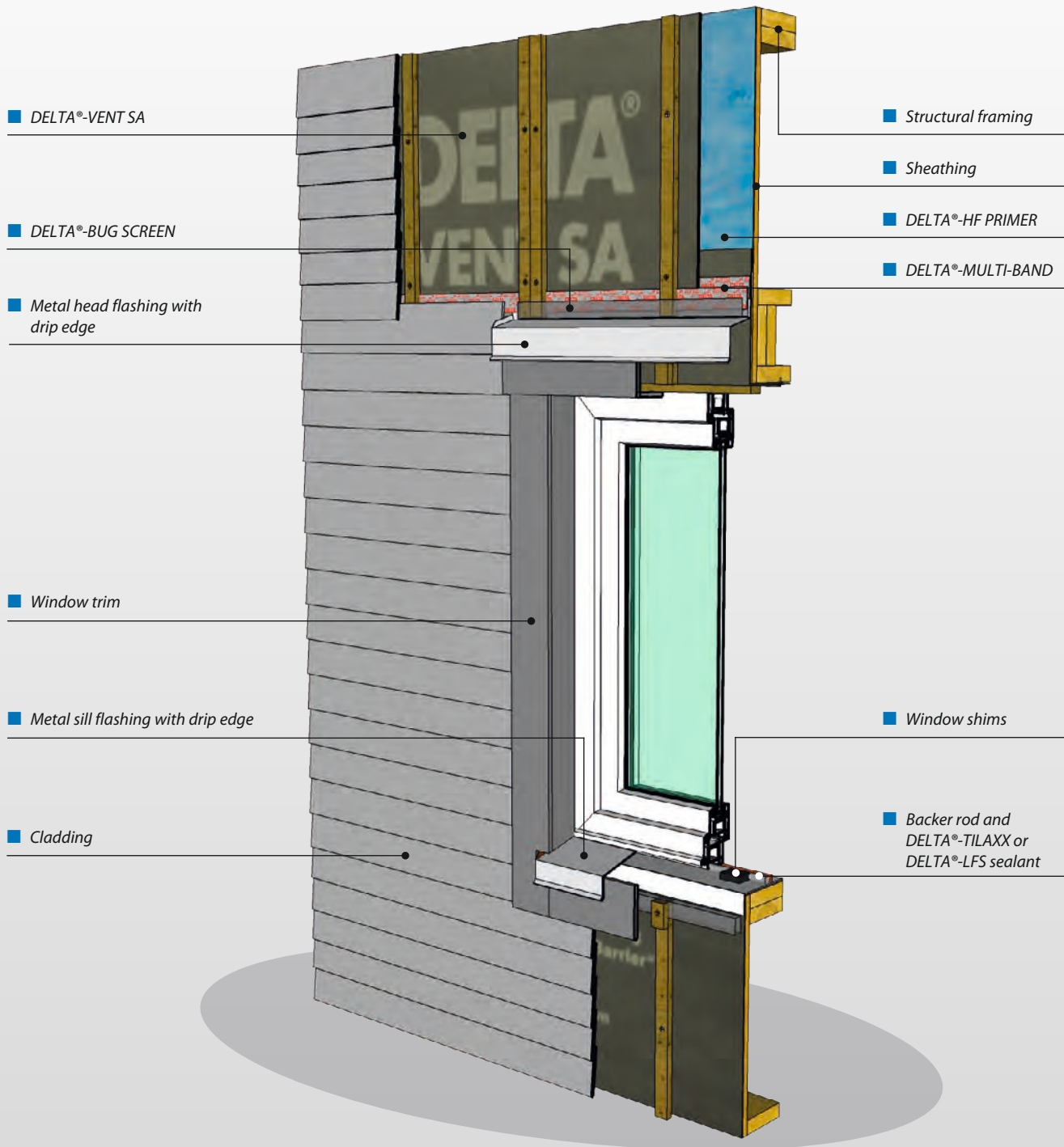



Cut-out method

6. With flat sill

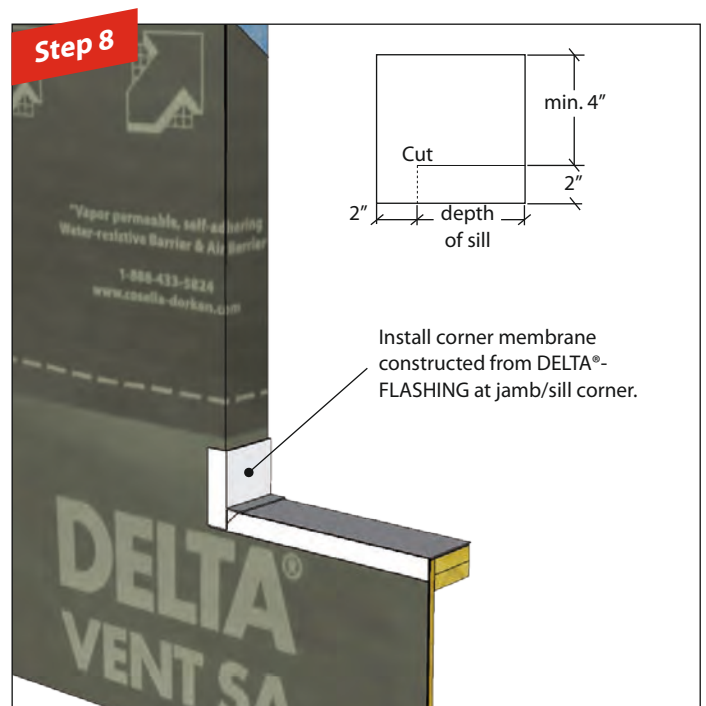
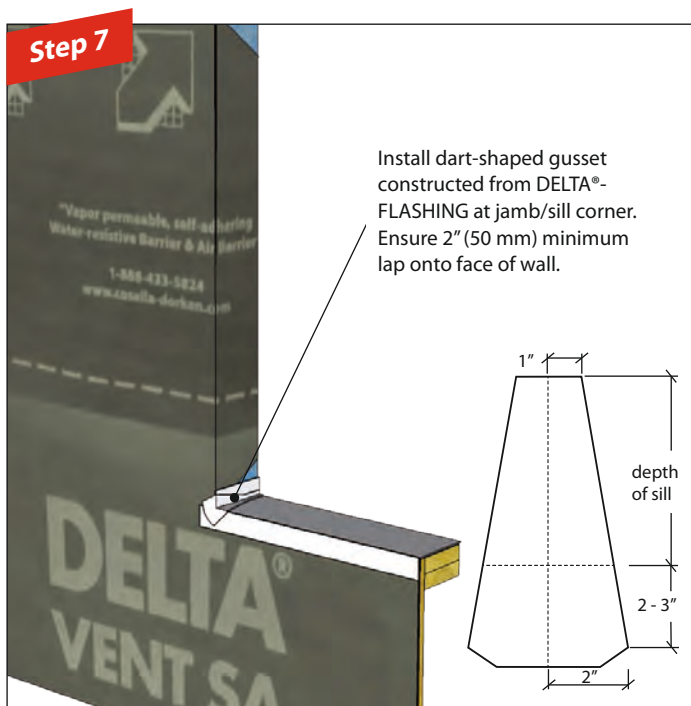
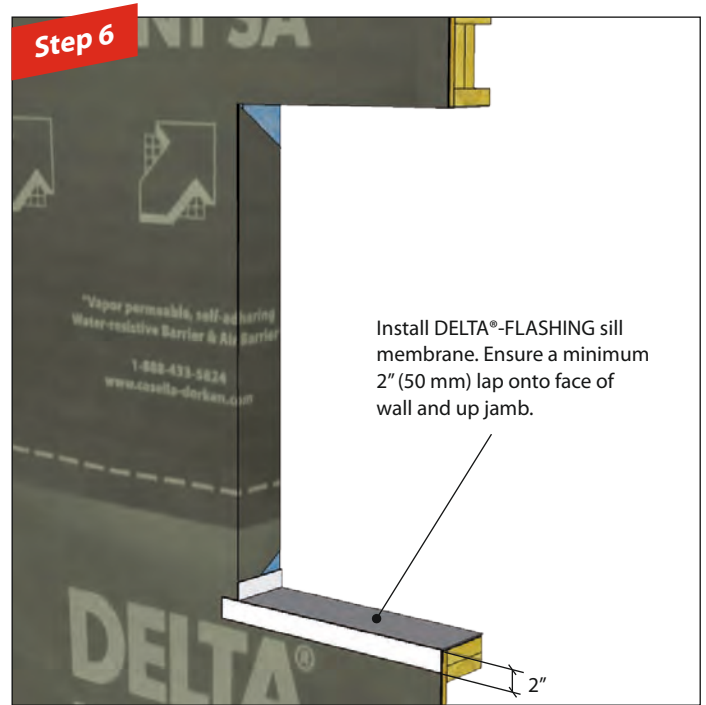

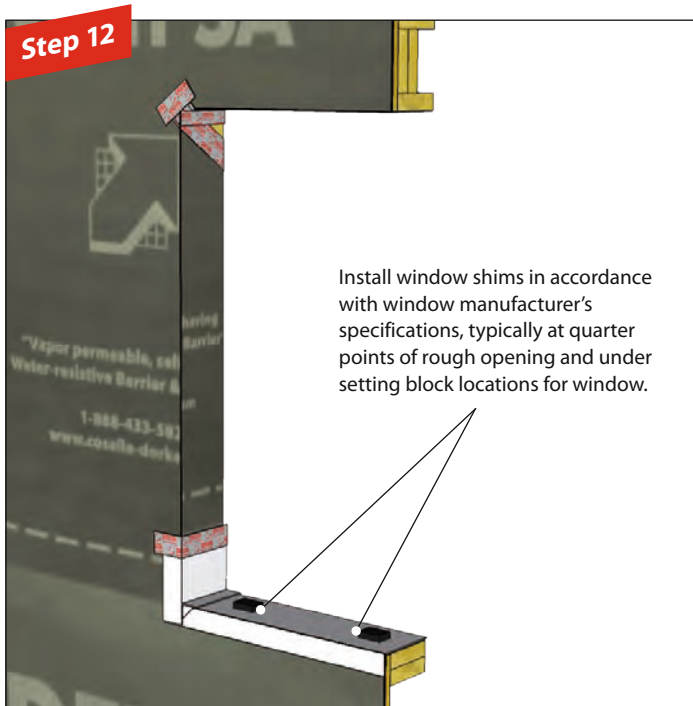
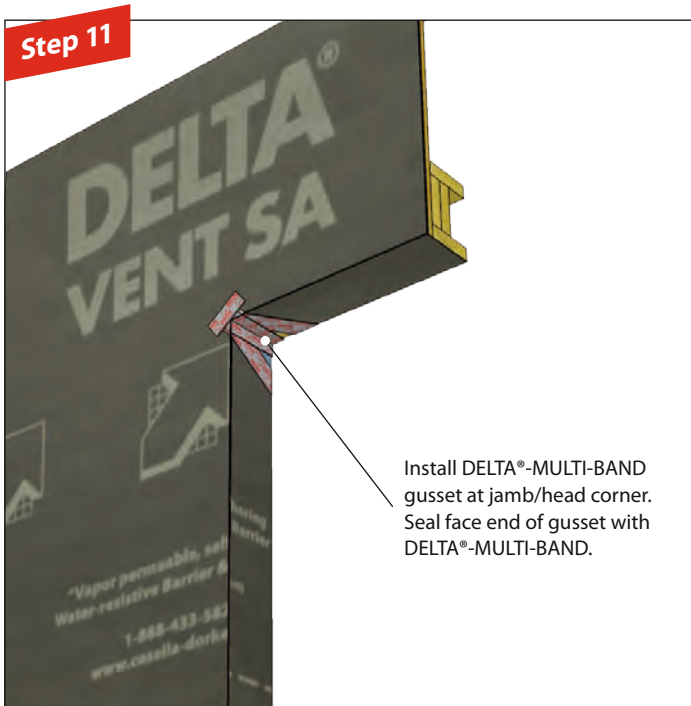
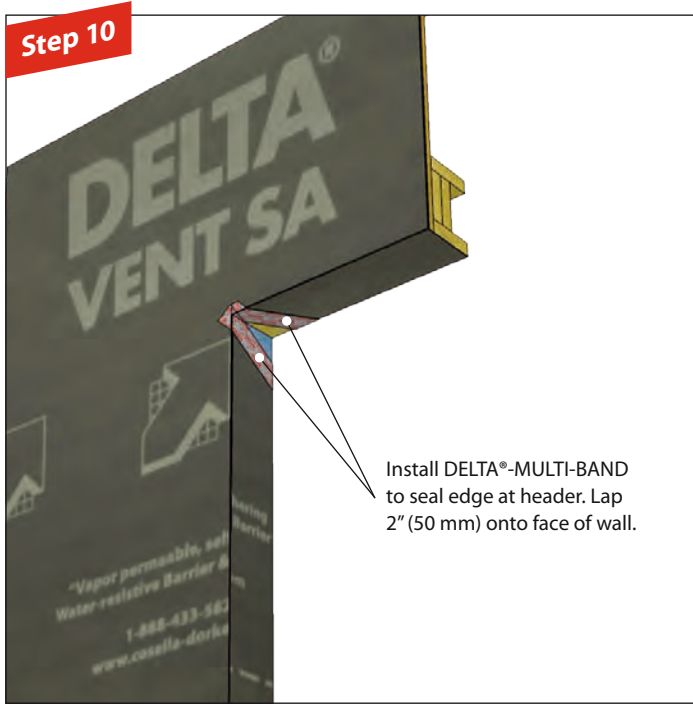

Cut-out method

6. With flat sill

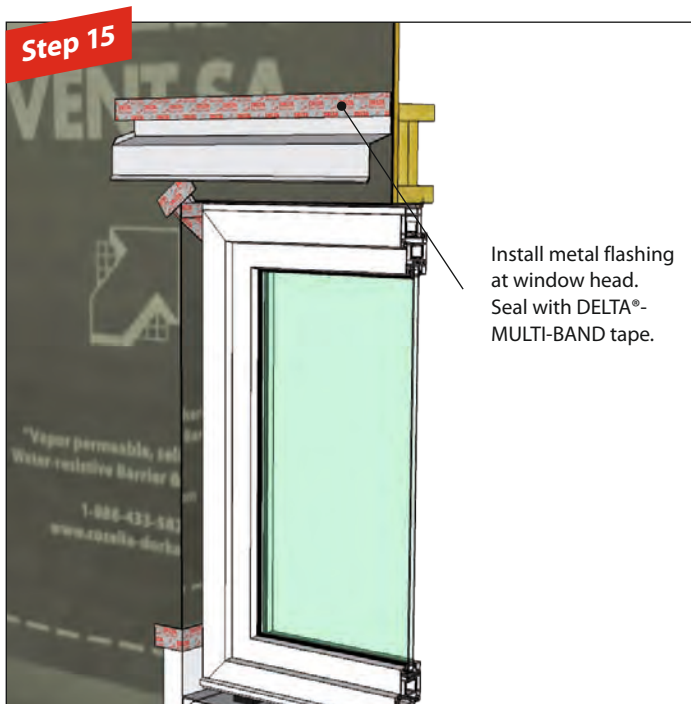
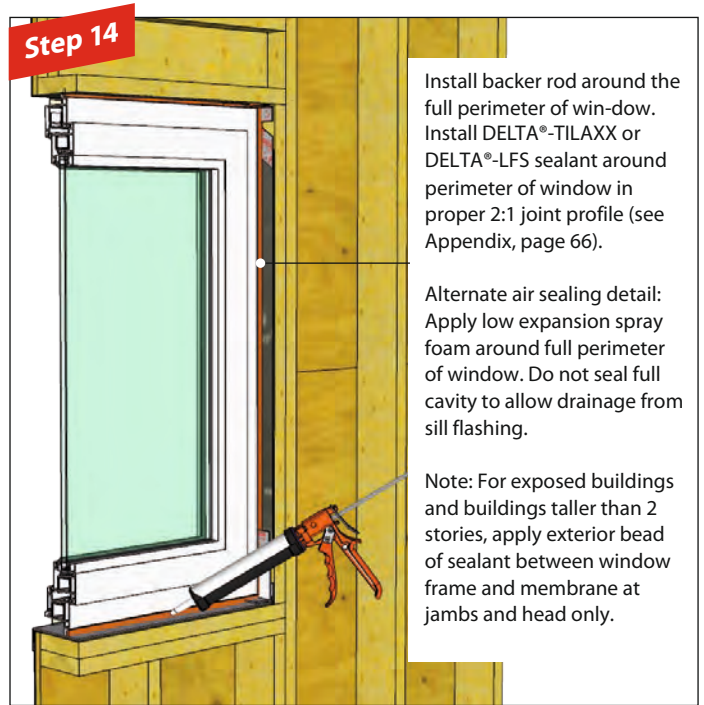

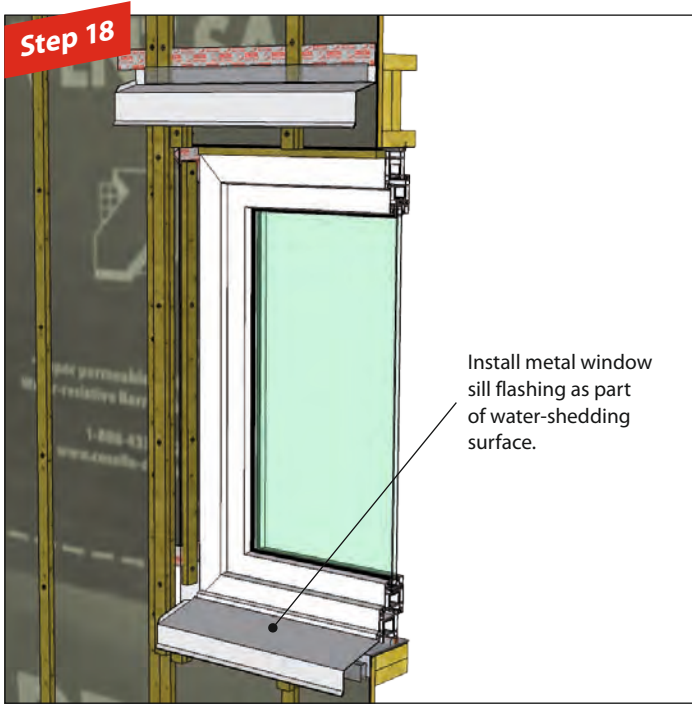

Cut-out method

7. With sloped sill

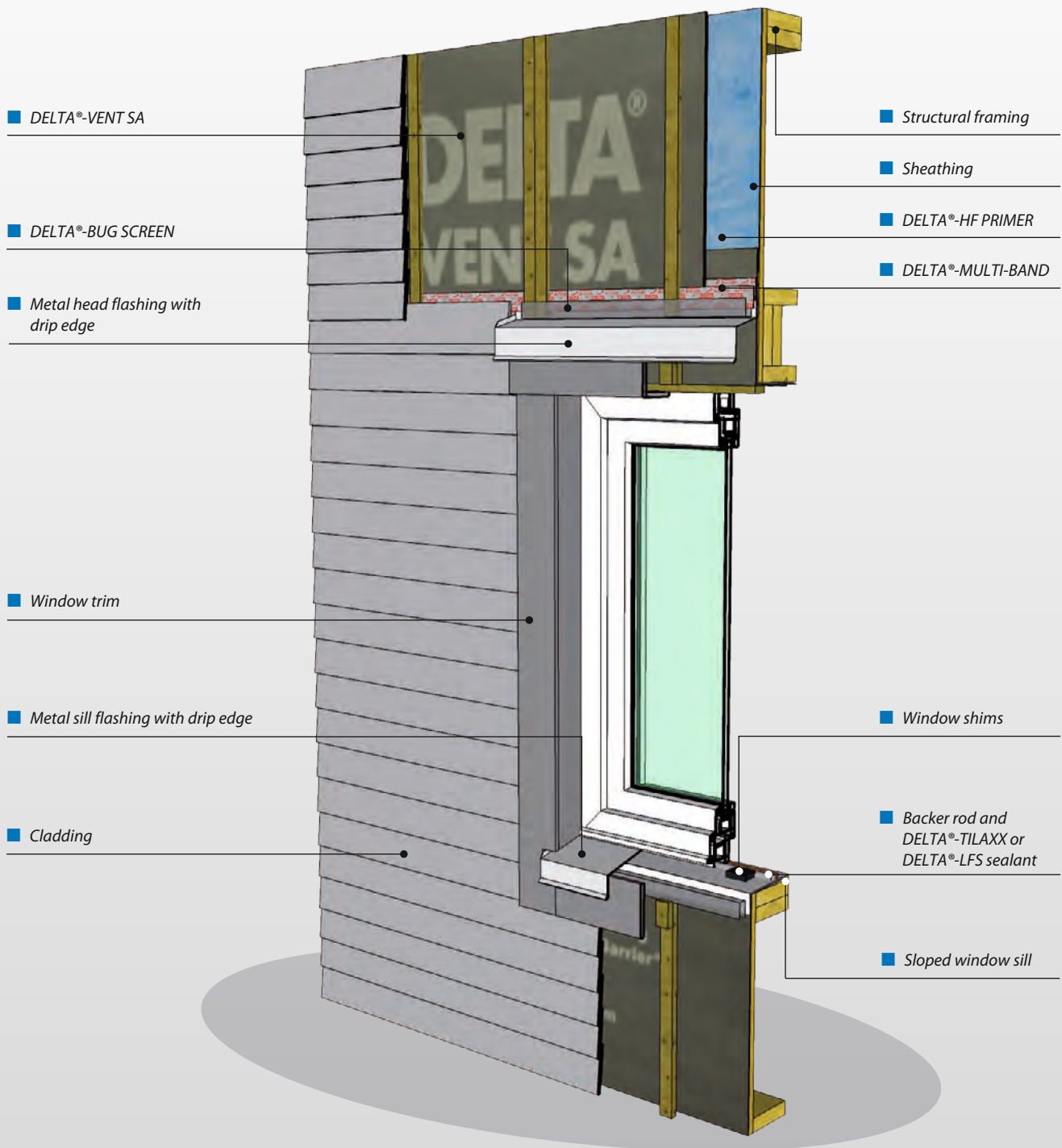



Cut-out method

7. With sloped sill

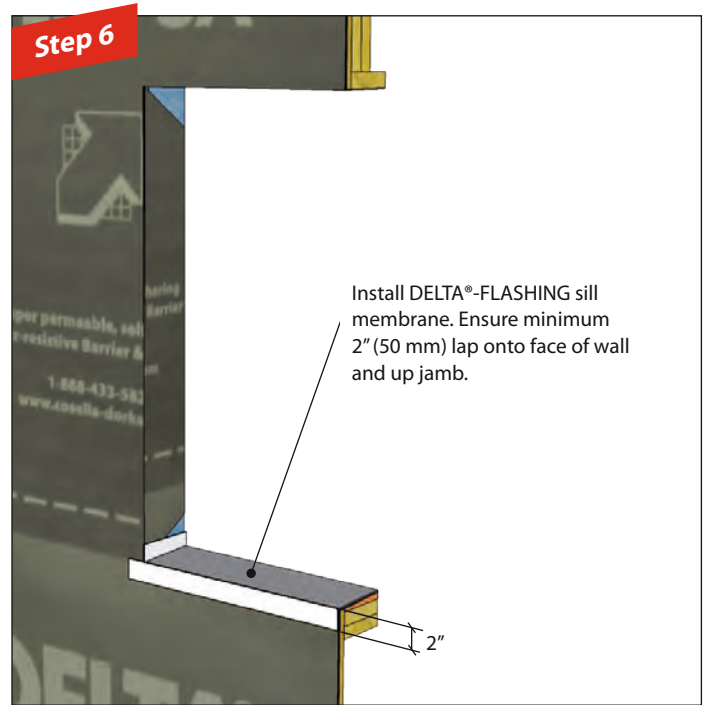

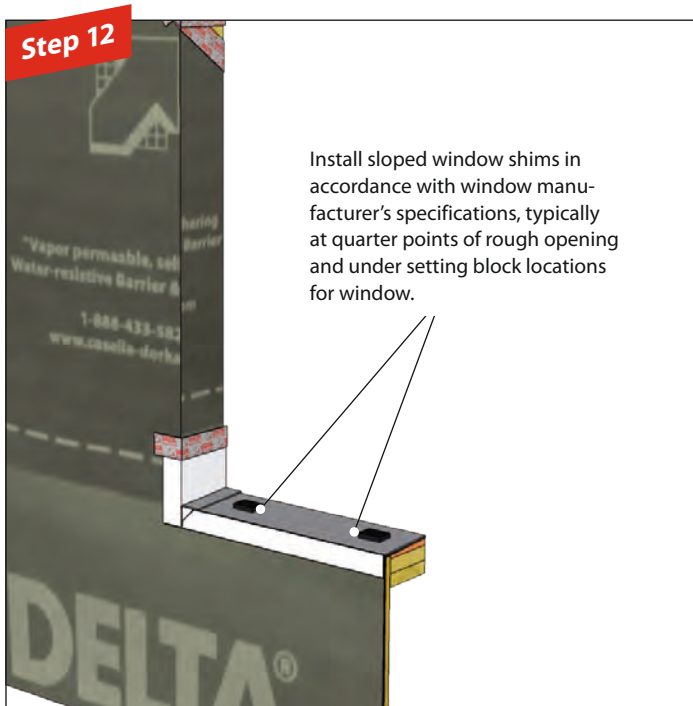

Cut-out method

7. With sloped sill

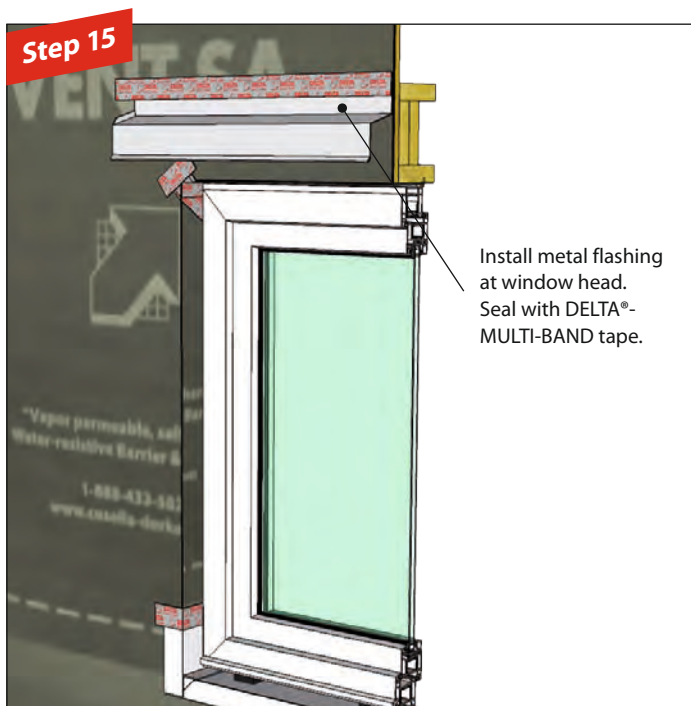
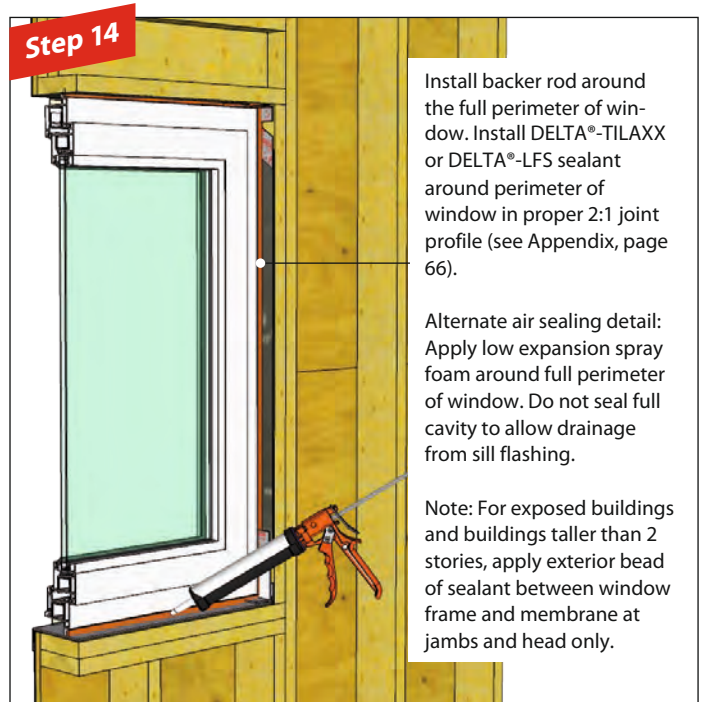

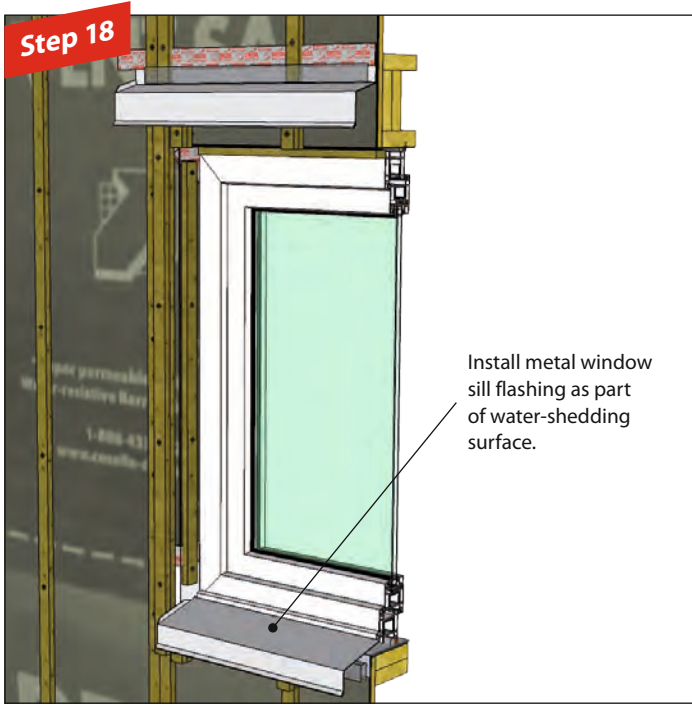

Cut-out method

8. With backdam

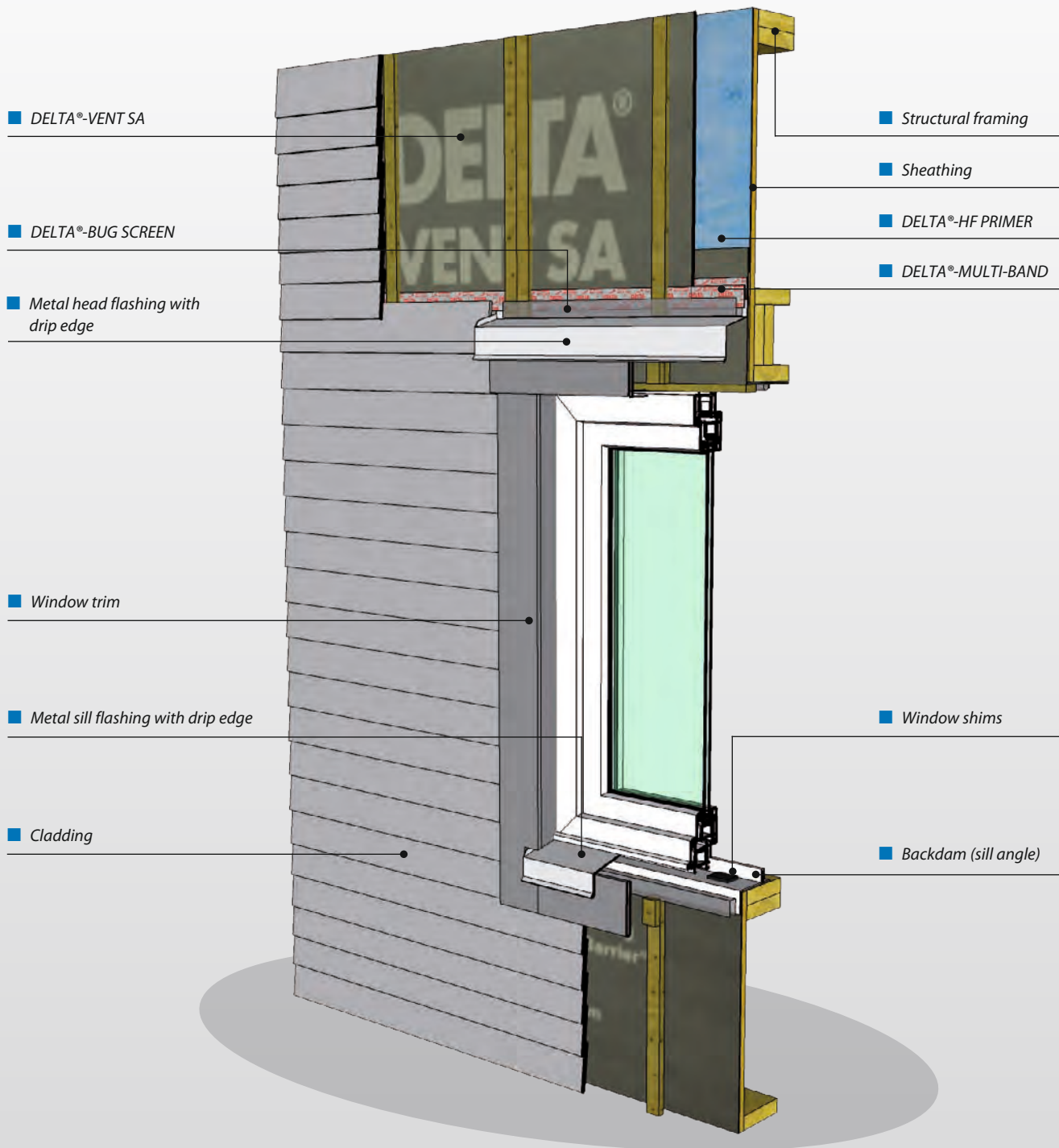



Cut-out method

8. With backdam



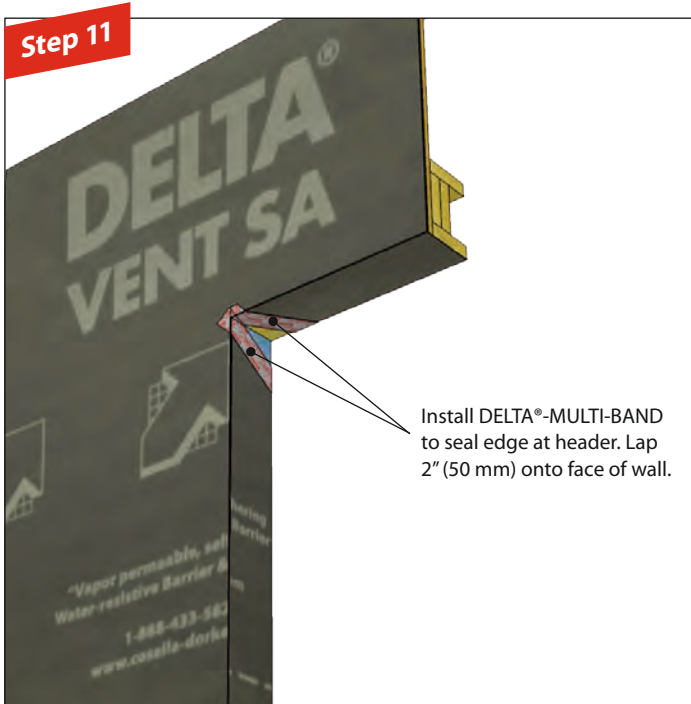
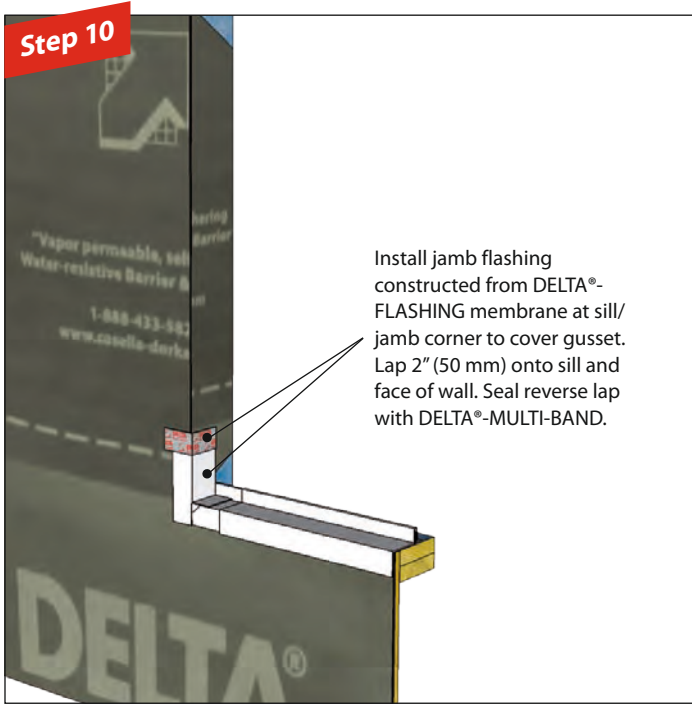

Cut-out method

8. With backdam

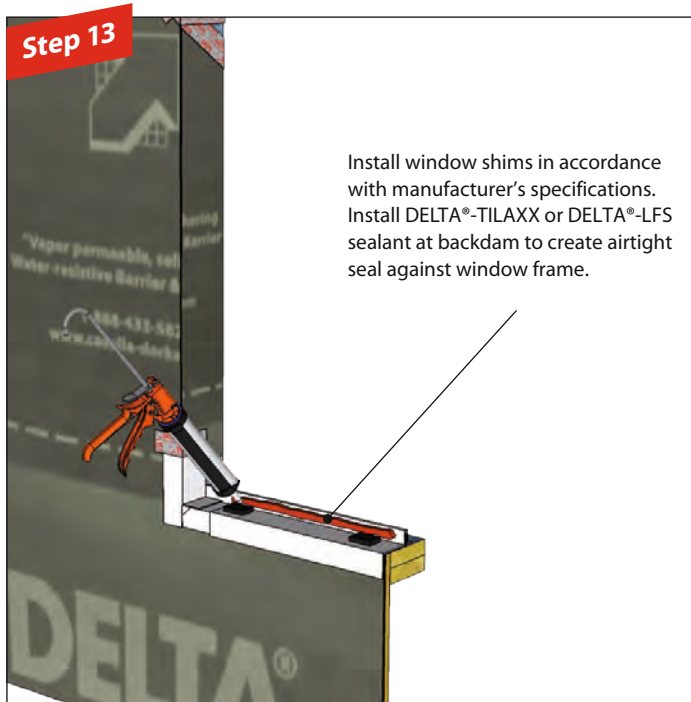

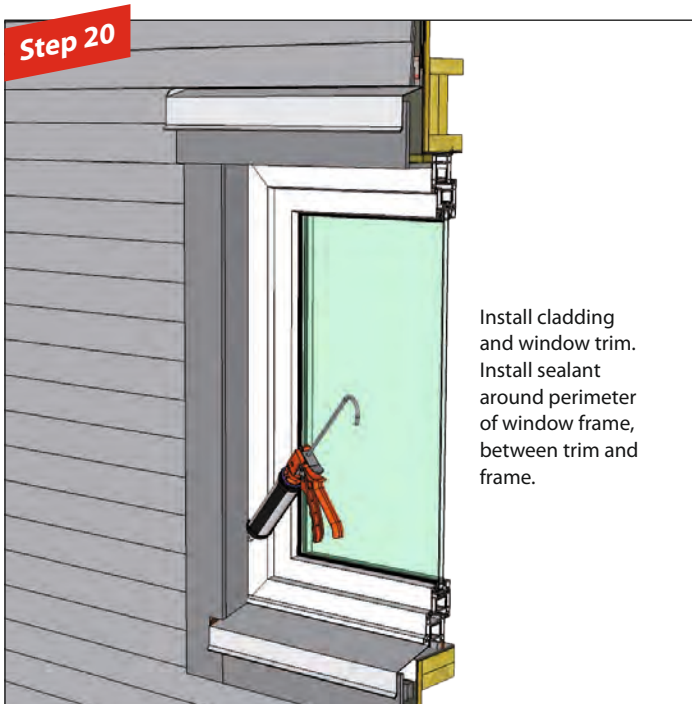
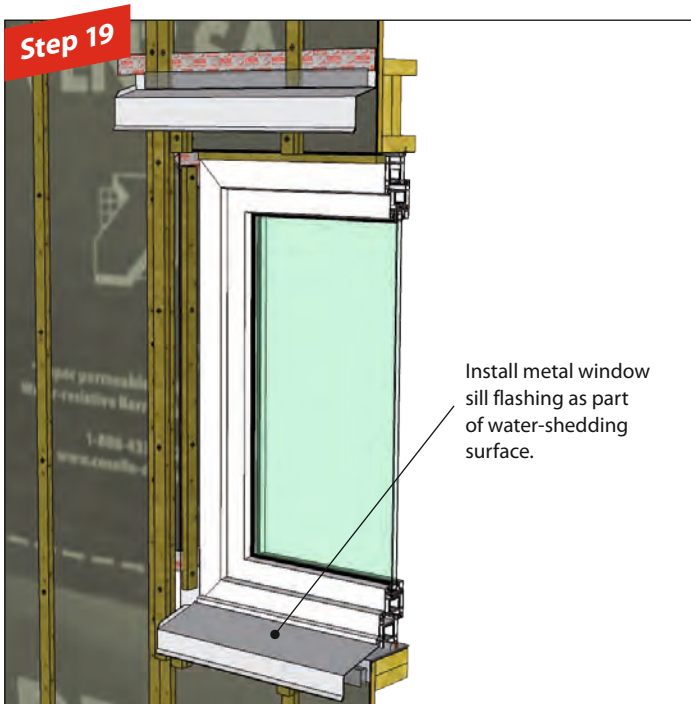

DELTA® Accessories

DELTA® Air Barrier System Components

Assuring an air-tight building enclosure

Using DELTA®-VENT SA to create an energy-efficient and air-tight building is a great choice. Choosing premium DELTA® Air Barrier System Components will help complete the job to meet the highest standards.

The secret to ensuring the overall effectiveness of an air barrier system is in the details, such as sealing windows, doors and penetrations. Proper attention to details is critically important to achieve an air-tight assembly. All components must be interconnected to successfully resist air and water infiltration, and turn individual materials, components and assemblies into a complete Air Barrier System.

DELTA®-Accessories are exhaustively tested for compatibility. Together they assure superior performance in air-tight building enclosures.

DELTA®-FLASHING is a best-in-class self-adhering membrane used to flash around window and door openings. Cut in practical and convenient widths, it provides superior long-term protection against air and water leaks.

DELTA®-MULTI-BAND is a very tough and durable seam tape with an aggressive pure acrylic adhesive. It is suitable for use at end and side laps or other detail areas. It sticks tenaciously to DELTA®-VENT SA as well as all other common construction substrates like OSB, plywood, metal, glass, etc.

DELTA®-FLEXX-BAND is a two-ply stretchable tape with a premium butyl rubber adhesive for use at penetrations such as service pipes, arched windows, window flanges, corners and joints. It is formed easily by hand into irregularly-shaped areas, forming a tight bond to wood, vinyl, metal and other common building materials.

DELTA®-FAS CORNER is a unique preformed corner for sealing windows and doors in air- and water-tight construction. Both durable and UV resistant, it provides top performance in detailing energy-efficient enclosures. DELTA®-FAS CORNER is easy to use and saves both time and labor during installation.

DELTA®-LFS is a one-part, moisture curing, room-temperature vulcanizing (RTV), 100% silicone adhesive and sealant that cures to form a low-modulus silicone rubber that maintains long-term adhesion and flexibility.

DELTA®-TILAXX is a high quality permanent-ly elastic adhesive and sealant for durable air-tight bonding to all common construction surfaces where moderate movement of components is expected.

DELTA®-HF PRIMER is a solvent free primer for self-adhering membranes used as per of surface conditioner. It consolidates surface dust on dirty construction site substrates, assuring reliable long-term air-tight adhesion for DELTA®-VENT SA.

The comprehensive line of DELTA-Accessories by Dörken delivers complete solutions for energy-efficient and durable building enclosures.



DELTA® Air Barrier System Components

			
<p>DELTA®-FLASHING</p>	<p>DELTA®-MULTI-BAND</p>	<p>DELTA®-FLEXX-BAND</p>	<p>DELTA®-FAS CORNER</p>
<p>Premium self-adhesive flashing membrane with aggressive tack.</p>	<p>Universal adhesive tape that sticks tenaciously and is highly resistant to aging.</p>	<p>Stretchable butyl-rubber compound tape with special carrier membrane.</p>	<p>Flexible pre-fabricated window corner. Permanently UV resistant.</p>
<p>Recommended Use</p> <ul style="list-style-type: none"> ■ For flashing of window and door openings. 	<p>Recommended Use</p> <ul style="list-style-type: none"> ■ For all DELTA® membranes to seal laps and penetrations. 	<p>Recommended Use</p> <ul style="list-style-type: none"> ■ Stretchable flashing for details and penetrations. ■ Pre-stretch where required. 	<p>Recommended Use</p> <ul style="list-style-type: none"> ■ Provides reliable air- and water-tight window details.
<p>Surface temperature min. +41 °F (+5 °C) Recommended storage: room temperature</p>	<p>Surface temperature min. +41 °F (+5 °C) Recommended storage: room temperature</p>	<p>Surface temperature min. +41 °F (+5 °C) Recommended storage: room temperature</p>	<p>–</p>
<p>Temperature Range -40 °F to +176 °F (-40 °C to +80 °C)</p>	<p>Temperature Range -40 °F to +176 °F (-40 °C to +80 °C)</p>	<p>Temperature Range -40 °F to +176 °F (-40 °C to +80 °C)</p>	<p>Temperature Range -40 °F to +176 °F (-40 °C to +80 °C)</p>
<p>Size Width: 6" (15.25 cm), 9" (23 cm) Length: 75' (22.85 m)</p>	<p>Size Width: 2 3/8" (6 cm), 4" (10 cm) Length: 82' (25 m)</p>	<p>Size Width: 4" (10 cm) Length: 33' (10 m)</p>	<p>Measurements 7" x 7" x 4" (18 cm x 18 cm x 10 cm)</p>



DELTA®-LFS	DELTA®-TILAXX	DELTA®-ADHESIVE	DELTA®-HF PRIMER
<p>Permanently elastic detail compound and sealant .</p>	<p>High quality permanently elastic adhesive and sealant that retains flexibility.</p>	<p>Solvent surface conditioner.</p>	<p>Solvent free primer for self-adhering membranes used as surface conditioner.</p>
<p>Recommended Use</p> <ul style="list-style-type: none"> ■ For sealing and adhering of DELTA® membranes. ■ Provides greater security in detail areas. ■ Suitable for areas with minimal movement of components. ■ Liquid flashing for windows and door opening. 	<p>Recommended Use</p> <ul style="list-style-type: none"> ■ For durable air-tight bonding to all common construction surfaces where moderate movement of components is expected. ■ Suitable for sealing of openings around windows (installed with backer rod). 	<p>Recommended Use</p> <ul style="list-style-type: none"> ■ Consolidates surface dust on dirty construction site substrates assuring reliable long-term air-tight adhesion. ■ Compliant with OTC rules for industrial adhesives and sealants and California South Coast Rule 1168. 	<p>Recommended Use</p> <ul style="list-style-type: none"> ■ Consolidates surface dust on dirty construction site substrates assuring reliable long-term air-tight adhesion. ■ Compliant with OTC rules for industrial adhesives and sealants and California South Coast Rule 1168.
<p>Application Conditions Open time: 0°C to 50°C (120°F)</p>	<p>Application Conditions Open time: 30 minutes at min. +41 °F (+5 °C)</p>	<p>Surface temperature Application conditions: min. -12 °C (10 °F) to 70 °C (104 °F) Recommended storage: min. 32 °F (0 °C)</p>	<p>Application conditions: min. 5 °C (40 °F) to 70 °C (104 °F) Recommended storage: min. 5 °C (40 °F)</p>
<p>Application Rate Approx. 23' (7 linear m) per cartridge</p>	<p>Application Rate Approx. 23' (7 linear m) per cartridge</p>	<p>Application Rate Up to 8.2 m²/l (350 ft²/gal.) depending on porosity and texture of surface.</p>	<p>Application Rate Up to 23 m²/l (250 ft²/0.26 gal.) depending on porosity and texture of surface.</p>
<p>Temperature Range -76°F to 392°F (-60°C to 200°C)</p>	<p>Temperature Range -22 °F to +176 °F (-30 °C to +80 °C)</p>	<p>Temperature Range -40 °F to +176 °F (-40 °C to +80 °C)</p>	<p>Temperature Range 5°C (40°F) to 70°C (150°F)</p>
<p>Size 10.2 fl.oz (300 ml) cartridge 20 fl.oz (600ml) sausage</p>	<p>Size 10.5 fl.oz (310 ml)</p>	<p>Size 4.5 gal (17 l)</p>	<p>Size 5 l (1.3 gal)</p>

Appendix

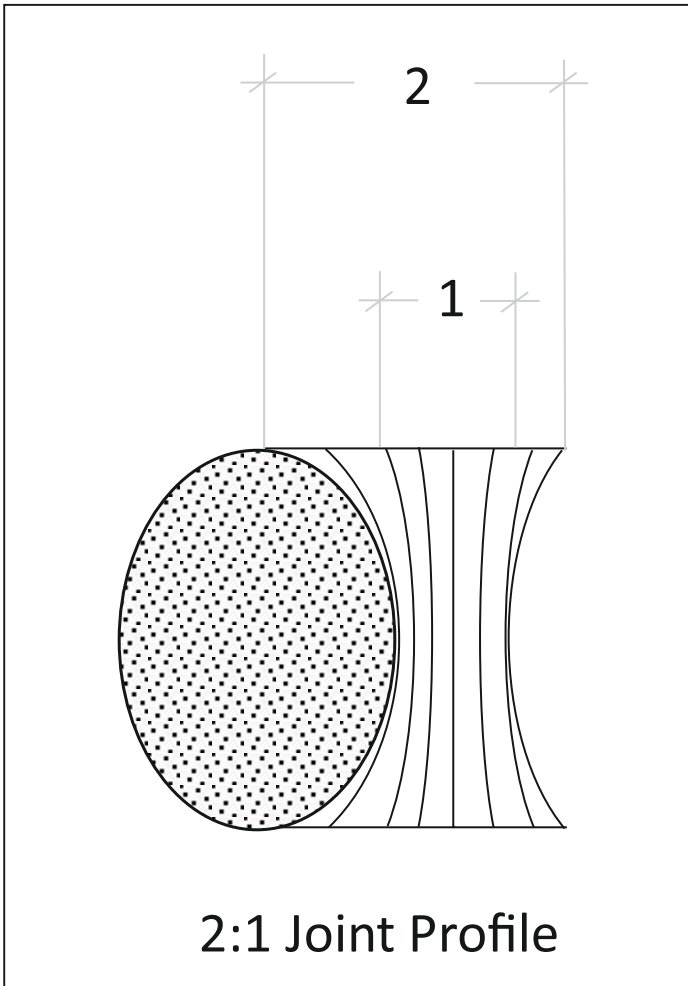

Recommended 2:1 Window Joint Profile

Notes

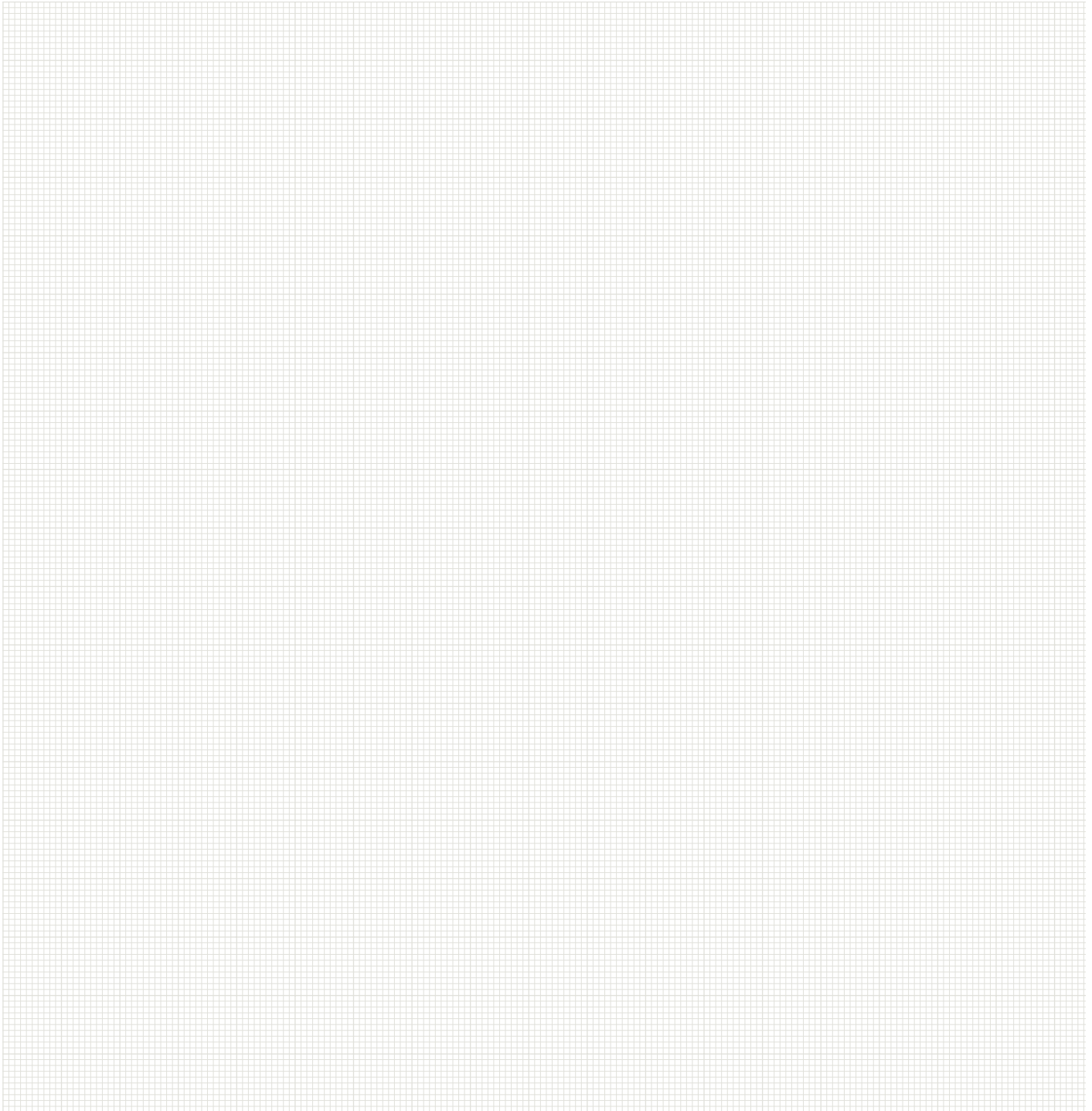

About Dörken

Dörken delivers innovative, premium quality products to the construction market. A North American manufacturer based out of Beamsville, Ontario, Dörken Systems Inc. is a subsidiary of the Dörken Group, a leading European developer and manufacturer of waterproofing and drainage products sold worldwide. Other top-performing WRBs from Dörken include DELTA®-FASSADE S, DELTA®-STRATUS SA and DELTA®-VENT S.

For more information, call 1-888-4DELTA4 (433-5824) or visit www.dorken.com

DELTA®



Dörken Systems Inc.
4655 Delta Way
Beamsville,
ON L3J 0T6, Canada
Tel.: +1 (905) 563 3255
Fax: +1 (905) 563 5582
info@dorken.com
www.dorken.com

A Dörken Group company



■ The information printed in this brochure reflects product information and specifications at the date of printing. The manufacturer reserves the right to make changes when necessary. All rights reserved. DELTA®-branded quality products manufactured by Dörken.

■ Visit us on:



LinkedIn



Twitter



YouTube

